

# Heating systems for steel industry

Heating facilities for the steel industry are subject to a variety of different requirements resulting from the particular process involved. Particular weight is given to process temperatures and the mode of operation of the furnace. Energy consumption and the necessary furnace atmosphere also have to be taken into consideration. In order to obtain optimum operating conditions, the heating system must be individually tailored to the specific application. This article explains the essential factors in system design and examines a number of practical solutions.



**Dipl.-Ing. Gerrit Wohlschläger**  
G. Kromschroder AG,  
Osnabrück (Germany)

Tel. +49 (0)541 / 1214462  
Email: g.wohlschlaeger@kromschroeder.com



**Dipl.-Ing. Martin Wicker**  
G. Kromschroder AG,  
Osnabrück (Germany)

Tel. +49 (0)541 / 1214624  
Email: m.wicker@kromschroeder.com

## Process requirements

With regard to process requirements in the iron and steel industry, the process temperature is an essential criterion. The spectrum extends from the low temperature range at approx. 200°C (for example in stress relief heat treatment) to temperatures in the range of approx. 1350°C, as typically used in heating furnaces for rolling and forging. In between lie the temperature ranges for annealing, quenching and tempering, hardening, normalising etc.

Another deciding factor in the design of the heating installation is the mode of operation of the furnace (intermittent or continuous). For example, intermittent operation is used for soaking pits as well as bogie hearth furnaces and batch furnaces used as forging furnaces or heat treatment furnaces. In these furnaces, the charge is heated from the initial temperature to the process temperature and then maintained at this temperature until it is completely heated through before being removed or cooled again in a controlled manner. This means that furnaces operated intermittently do not achieve a steady state, as the furnace chamber temperature or the required heat input is continually changing. In continuous systems, such as rolling mill furnaces, belt annealing, strip galvanising plants etc, there is usually a quasi-steady state. In these furnaces, the charge is transported through the furnace and the operating conditions (temperature and required heat input) only change within narrow limits.

Energy consumption also plays an important role. Taking the process temperatures and mode of operation into account, a check should always be made as to whether it may be worthwhile installing recuperative or regenerative systems to preheat the air.

The furnace atmosphere also makes demands on the type of heating. In many processes, it is not only the temperature curve that has to be maintained but also a certain atmosphere. To do this, the following points are examples of what has to be considered:

- Will work be carried out in a protective atmosphere and does this require indirect heating?
- In the case of direct heating, are oxygen-sensitive products involved and does excess air on the burner and false air therefore have to be avoided or, on the contrary, may an increased

O<sub>2</sub> value in the furnace atmosphere be desirable/required?

## Output control

Depending on the process, the type of output control has to be established. This can be modulating or cyclical (Fig. 1).

With modulating control, the gas and air flow are adjusted in relation to the required output for the process e.g. by means of flow measurements and control valves and the control of the burner output is therefore infinitely variable. This type of control is mainly applied in continuous processes and at high temperatures, e.g. in rolling mill furnaces. In this area, the heat transfer mainly occurs via radiation; convective heat transfer is only of minor significance. Even in low temperature processes with forced circulation of the furnace atmosphere as well as single

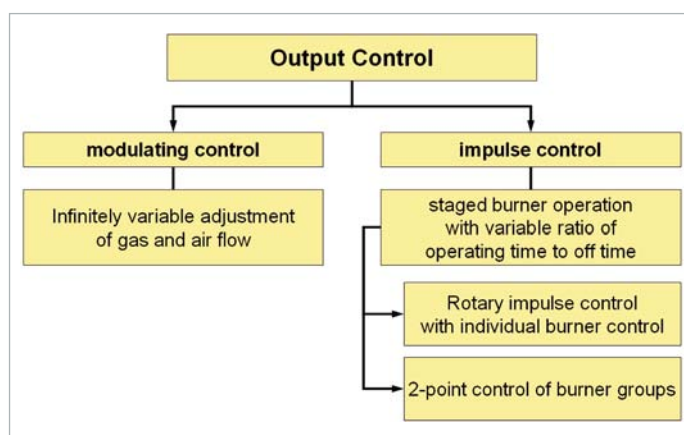

**Fig. 1:** Output control possibilities

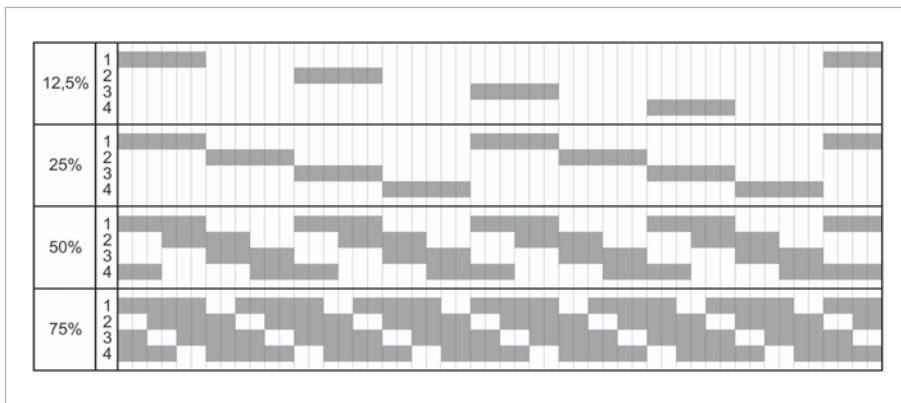

Fig. 2: Output control by means of cyclical operation

burner systems, continuous control is frequently present.

In the case of impulse control, the control of the output supplied to the process is achieved by means of a variable ratio of the operating time to the pause time of the burner. To do this, the burners are switched on and off or are run at High/Low. Fig. 2 shows an example of impulse control with four burners and four different outputs.

With this type of control, full momentum is always in effect and maximum convection is always obtained, even with reduced heating rate. This facilitates a good uniformity of temperature even at low process temperatures.

Another big advantage is that in principle with impulse control there are no limitations on the control range. By dividing the burners into individual zones and by the appropriate parameterisation of the cyclical control there are a great many possible variations.

**Burners**

The burners are a fundamental factor in the design of the heating system. They virtually provide the interface to the process. In principle a distinction is made

between burners with flames directed forwards and burners with short flames often flat to the furnace wall. Fig. 3a shows a high-speed burner with a high-speed flame directed forwards normally used with cyclical operation. The flat-flame burner shown in Fig. 3b is mainly used at high temperatures where the heat is only transferred by solid-state radiation.

The design of the burner determines the flame shape and is therefore an important factor in tailoring the heating system to the process. On the one hand, there is the option of combining the burner with a burner quarl made of refractory concrete, on the other hand, the modular nature of the burners means a ceramic combustion chamber in SiC material can be flange-mounted. Suitable SiC materials are available in appropriate grades and dimensions. By selecting the outlet diameter on the ceramic combustion chamber, various outlet velocities can be achieved for the flue gases. In this way, a considerable influence can be exerted over the circulation of the atmosphere in the furnace and thereby over the process, too.

These types of burners with flange-mounted ceramic combustion chambers

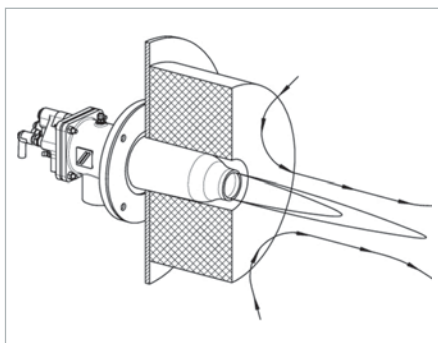

Fig. 3a: High-speed burner for circulation of furnace atmosphere under cyclical operation

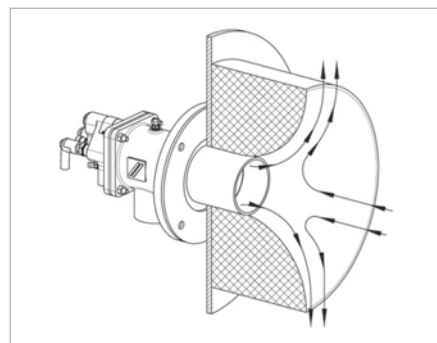

Fig. 3b: Flat-flame burner in the form of a radiant burner

are usually used in furnaces with a ceramic fibre lining. This type of lining is state of the art.

The mixing head, as the “heart” of the burner, facilitates a further effect on the flame geometry. The machined finish of the mixing heads allows a high degree of flexibility. Depending on the form of the grooves and holes, short, sharp flames or longer, softer flames can be produced. Fig. 4a and b show two different designs of mixing head.

The design of the mixing head also influences the burner emissions. Mixing

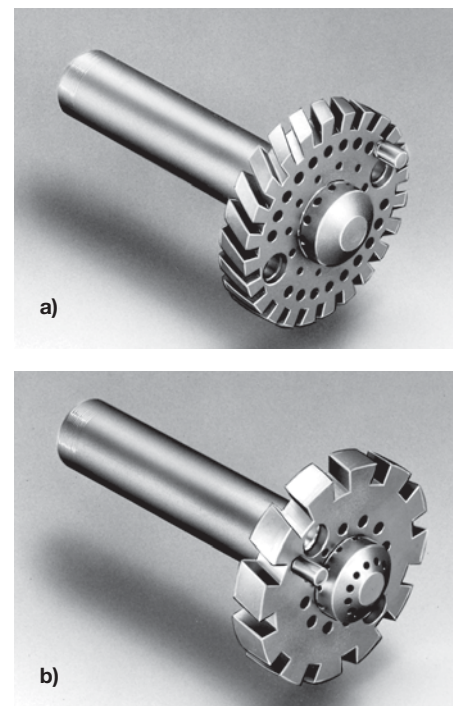

Fig. 4a and b: Mixing heads

heads with a high degree of air spin and resultant rapid combustion, especially when operated with preheated combustion air, tend to form NO<sub>x</sub>. On the other hand, a “slower” head mixing in stages will, in a “cold” environment, lead to increased CO values. A suitable burner has to be chosen to comply with emission limits for the whole system.

**Examples from practical applications**

**Walking beam furnace**

The walking beam furnace (MAERZ) shown in Fig. 5 in a plate rolling mill has a combination of two types of heating (flat-flame and high-speed burners).

In the furnace, sheet metal plates in different thicknesses (between 5 and 100

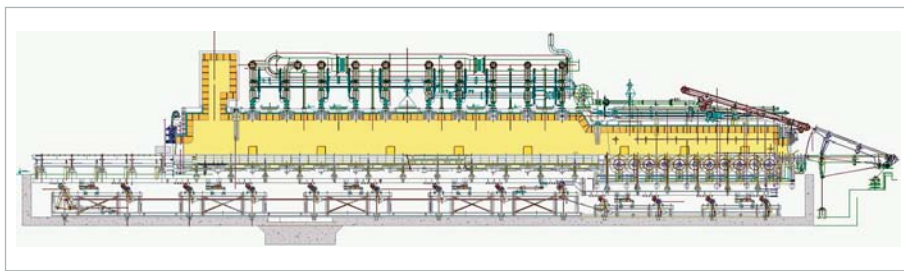

Fig. 5: Maerz walking beam furnace (longitudinal section)



Fig. 6: Bogie hearth furnace with BIC high-speed burners

mm) and of different grades are heated to the required temperature. This requires a high degree of flexibility. This is why the decision was taken to combine flat-flame burners in the roof with high-speed burners positioned at the sides in the soaking zone. The furnace is equipped with a central recuperator, which supplies the burners with preheated combustion air.

Flat-flame burners can be used in high temperature applications as they are usually manufactured in highly heat-

resistant steel. However, due to their design, they are greatly exposed to the radiation in the furnace. Therefore, the burners can be equipped with ceramic radiation protection in sensitive areas consisting of a similar material to the burner tubes described above. This guarantees that the burner can withstand radiation even when switched off and without cooling air (which would be extremely damaging for the process).

The control of this type of furnace demands special requirements. This does not only concern the burners but also other components which ensure the correct gas/air mixture. These include, for example, “intelligent” valves, which offer the possibility of reacting accordingly to the preheating of the air. On the one hand, these valves can be used for On/Off operation but in addition, a signal can be feedforwarded, e.g. in the event of increased preheating of the air, to open the valve further while maintaining cyclical operation [1] at the same time. Several options can therefore be combined with each other and this is necessary for certain processes. This requires appropriate control elements and automatic burner control units, which work in harmony with the system.



Fig. 7: LOI bell-type annealing installation

### Bogie hearth furnace for heat treatment

Fig. 6 shows a bogie hearth furnace for heat treatment. Here the burners fire on the left and right offset under the superstructure. They are run in cyclical operation (On/Off). The impulse system is used to control the individual zones accordingly. In this type of firing, the aforementioned high-speed burners are generally used. Their outlet velocities are between 70 and 130 m per second depending on the type of flange-mounted ceramic burner tube. Due to the high outlet velocity, the atmosphere circulates in the furnace in accordance with the cyclical operation.

It is important to ensure that the heating system for a furnace is not overdimensioned, i.e. that the installed burner output is adapted to the process. Overdimensioning means less circulation in the furnace as the burners are not switched on so often. Burners, which are not in operation, also always mean false air due to leakage from the air control valves. This causes the O<sub>2</sub> concentration in the furnace to increase, which results in higher energy consumption and perhaps also greater scaling of the heated product.

### Bell-type annealing furnace

The bell-type annealing furnaces (LOI) shown in Fig. 7 also illustrate how the heating system can react to process requirements. The coils piled on to a base are covered with a protective hood filled with hydrogen. The indirect heating of the protective hood is carried out by means of the heating hood placed on top in which the burners are installed in a tangential arrangement.

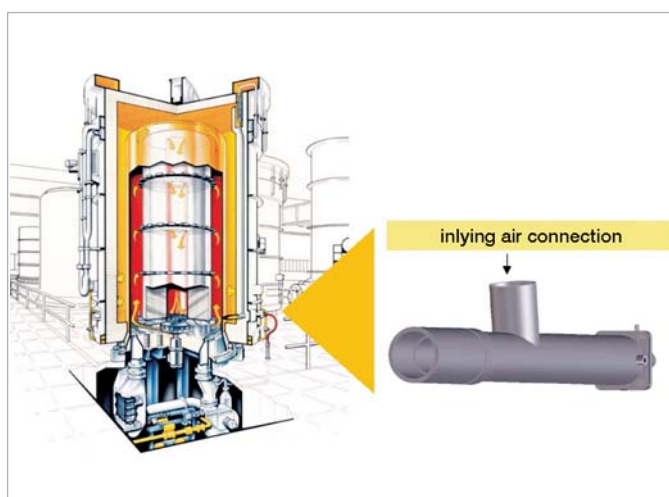

Fig 8: Section through the bell-type annealing furnace (LOI)

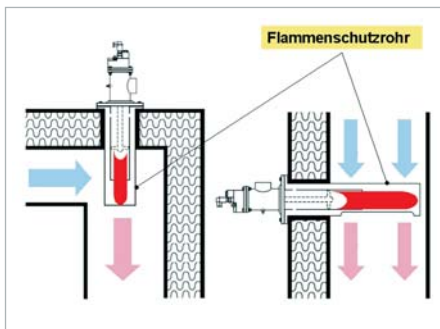

Fig 9: Burner system with protective tube

Fig. 8 clarifies the special requirements of the furnace. The combustion air flows over a recuperator integrated into the heating hood and then to the burner preheated by pipes in the insulation. The burner has a special housing so it can be adapted to the design of the system. Furthermore, a special mixing head has been selected here, which guarantees a long, staged flame with a low formation of NO<sub>x</sub>.

**Tempering furnace with hot gas circulation**

Tempering furnaces operate in the “lower” temperature range. The heat transfer here mainly occurs by convection. Hot gas circulation by means of fans installed in the furnace is an adequate alternative in this case. This results in particular heating requirements. The burners are located in sheet metal flues and the flame has to be protected by an additional tube depending on the velocity of the circulation flow. Fig. 9 shows two possible options. The

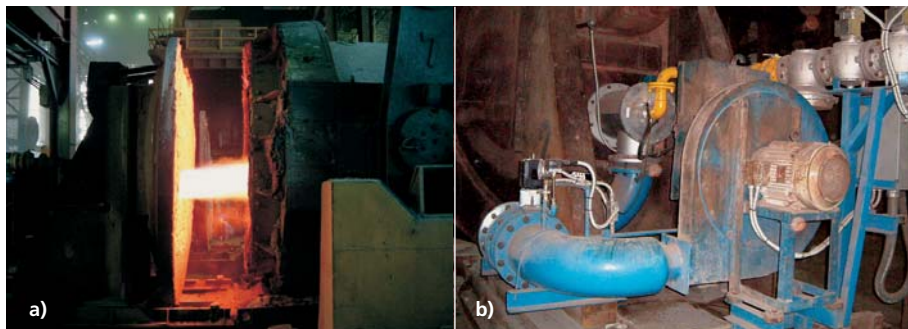

Fig. 10a and b: ZIO individual burner in modulating mode

hot combustion gases are emitted depending on the installation either at the side or front of the protective flame tube. This guarantees the complete combustion of the flame without resulting in burner malfunctions or CO formation.

**Individual burner applications**

Individual burners are usually equipped with modulating control in the gas/air side group. Fig. 10 shows a ladle heater equipped with a 2 MW-ZIO burner with

continuous control and pneumatic gas/air linkage.

The BIT-type burner shown in Fig. 11 is specially used for tempering. At a constant set maximum air flow, the burner output is controlled in modulating mode and the required temperature is thus achieved. This type of heating is used, for example, in the tempering of newly lined ladles.

**Conclusion**

In conclusion, it can be said that a universal heating installation for all processes and applications does not exist and will not exist for a long time to come. Therefore, the examination must always take into consideration the special features of the individual process as well.

**Literature**

[1] Wohlschläger, Dossow: Modern heating system with flat flame burners on rolling mill furnace, HEAT PROCESSING, May 2004, Pages 29-31

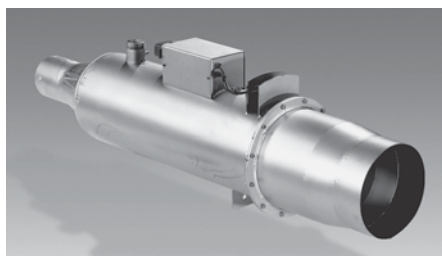

Fig 11: BIT tempering burner