

Compact flame oxygen-fuel burners OXY-THERM® TITAN™

TECHNICAL INFORMATION

- High temperature oxy-fuel flame reduces fuel consumption
- Sealed, self-cooling design minimizes air infiltration and maintenance
- Wide variety of capacities and large turndown ratio (8:1) provide precise process temperature control
- Compact flame geometry for easy integration in most processes
- Clean combustion with any fuel gas, including an up to 20% hydrogen/80% natural gas fuel blend
- Ignition flexibility with air or oxygen pilots
- Typical applications include ladle heating, reheat furnaces, rotary hearths, forge furnaces, reaction furnaces, and any high temperature, sealed process

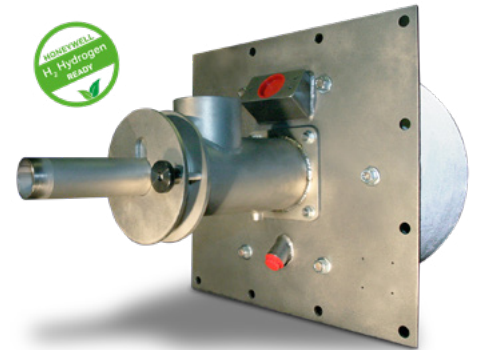

Contents

Contents	2
1 Application	3
2 Function	4
2.1 Part designations	4
2.2 Expected emissions	4
3 Selection	5
3.1 Imperial	5
3.2 Metric	6
3.3 Burner blocks	7
3.4 Selection table	7
4 Project planning information	8
4.1 Combustion oxygen pressure vs. flow	8
4.2 Combustion oxygen pressure - 1 1/2" burners	8
4.3 Combustion oxygen pressure - 2" burners	9
4.4 Flame lengths - 1 1/2" burners	9
4.5 Flame lengths - 2" burners	10
4.6 Process temperatures	10
4.7 Ratio control	10
4.8 Flame supervision	10
4.9 Fuels	10
5 Accessories	11
5.1 Oxy-pilot	11
5.2 Air-fuel boosted pilot	12
6 Technical data	13
6.1 Mechanical construction	13
6.2 Dimensions	14
For more information	16

1 Application

OXY-THERM TITAN burners can be used in furnaces, melters, unit melters, reverberatory furnaces, ladles, waste incinerators, process heaters and other high temperature applications.

They have a unique design which minimizes flame length. For applications such as ladle heating or rotary melting, chamber length will often be compact, making it necessary to use a burner with a compact flame to avoid damaging the end or bottom of the chamber.

OXY-THERM TITAN burners have a mounting flange and block design that will accommodate vertical fired applications requiring “down fired” mounting or for units that require mounting onto removable/hinged doors like rotary melters.

OXY-THERM TITAN burners are available in two sizes: 1-1/2” and 2”. Each size may be customized to your capacity needs. Standard refractory block material is suitable for furnace temperatures up to 3000°F (1649°C). Optional materials for more challenging environments are available upon request.

2 Function

The OXY-THERM TITAN burners provide a more compact flame profile than other OXY-THERM burners. Its flame length and mounting design make it ideal for applications requiring higher capacities in vertical fired applications requiring a “down-fired” mounting such as ladle preheating. It is also an excellent burner for rotary melters, waste incinerators and process heaters.

Oxygen enters the burner housing and exits around the fuel nozzle where it mixes with the fuel. The oxygen-fuel flame discharges through the refractory block throat and develops a tightly wrapped compact flame pattern.

Oxy-fuel pilots and air-fuel pilots are available.

OXY-THERM TITAN burners are available with refractory block only.

2.1 Part designations

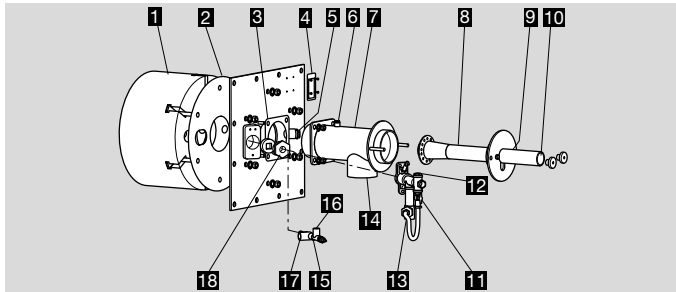

- 1 Block
- 2 Block gasket
- 3 Housing gasket
- 4 Nameplate

- 5 3/4" NPT coupling location for optional flame sensing device
- 6 1/4" NPT combustion oxygen pressure tap
- 7 Housing
- 8 Nozzle body
- 9 1/4" NPT fuel gas pressure tap (hidden)
- 10 Fuel gas inlet
- 11 Optional sealed boosted air-fuel pilot
- 12 3/8" NPT gas inlet
- 13 3/8" NPT air inlet
- 14 3" NPT combustion oxygen inlet
- 15 Optional Oxy-fuel pilot
- 16 3/8" NPT gas inlet
- 17 1/2" NPT oxygen inlet
- 18 Oxy-fuel pilot bushing

2.2 Expected emissions

Exact emissions performance may vary in your application. Contact Honeywell Maxon for information on installation specific estimates. No guarantee of emissions is intended or implied.

3 Selection

3.1 Imperial

Typical burner data

Stated pressures are indicative. Actual pressures are a function of air humidity, altitude, type of fuel and gas quality.

Natural gas

- » Fuel: Natural gas at 60°F with 1000 BTU/ft³ (st) HHV – sg = 0.6¹⁾, Oxygen: 90–100% purity

Size	Maximum capacity range ²⁾	Turndown	Pressures required to burner inlet for maximum capacities		Typical oxygen to fuel volumetric ratios
			Natural gas	Oxygen	
			MBTU/h	psig	psig
1 1/2"	2–12	8:1	<10.3 ³⁾	2.0	2.05:1
2"	10–30	8:1	<10.3 ³⁾	4.1	2.05:1

Natural gas mixed with hydrogen

- » Fuel: 80 % Natural gas/20 % Hydrogen at 60°F with 863 BTU/ft³ (st) HHV – sg = 0.49¹⁾, Oxygen: 90–100% purity

Size	Maximum capacity range ²⁾	Turndown	Pressures required to burner inlet for maximum capacities		Typical oxygen to fuel volumetric ratios
			80 % NG/20 % H ₂	Oxygen	
			MBTU/h	psig	psig
1 1/2"	2–12	8:1	<11.34 ³⁾	1.93	1.74:1
2"	10–30	8:1	<11.34 ³⁾	3.97	2.05:1

¹⁾ sg (specific gravity) = relative density to air (density air = 0.0763 lb/ft³) (st)

²⁾ Capacities in BTU/h refer to the higher heating value HHV (gross calorific value).

³⁾ Nozzles drilled per order to accommodate various fuels, available supply pressures, and desired capacity.

3.2 Metric

Typical burner data

Stated pressures are indicative. Actual pressures are a function of air humidity, altitude, type of fuel and gas quality.

Natural gas

- » Fuel: Natural gas at 15°C with 10.9 kWh/m³ (st) HHV – sg = 0.6¹⁾, Oxygen: 90–100% purity

Size	Maximum capacity range ²⁾	Turndown	Pressures required to burner inlet for maximum capacities		Typical oxygen to fuel volumetric ratios
			Natural gas	Oxygen	To natural gas
			mbar	mbar	
	kW				
1 1/2"	529–3173	8:1	<710 ³⁾	138	2.05:1
2"	2644–7932	8:1	<710 ³⁾	283	2.05:1

Natural gas mixed with hydrogen

- » Fuel: 80 % Natural gas/20 % Hydrogen at 15°C with 8.933 kWh/m³ (st) HHV – sg = 0.49¹⁾, Oxygen: 90–100% purity

Size	Maximum capacity range ²⁾	Turndown	Pressures required to burner inlet for maximum capacities		Typical oxygen to fuel volumetric ratios
			80 % NG/20 % H ₂	Oxygen	To 80 % NG/20 % H ₂
			mbar	mbar	
	kW				
1 1/2"	529–3173	8:1	<782 ³⁾	133	1.74:1
2"	2644–7932	8:1	<782 ³⁾	274	2.05:1

¹⁾ sg (specific gravity) = relative density to air (density air = 0.0763 lb/ft³) (st)

²⁾ Capacities in kW refer to the lower heating value LHV.

³⁾ Nozzles drilled per order to accommodate various fuels, available supply pressures, and desired capacity.

3.3 Burner blocks

OXY-THERM TITAN burners are available with refractory block only.

Block material

Type	Alumina/Mullite
Maximum temperature	3000°F (1650°C)

In addition to maximum furnace temperatures, temperature variations and furnace atmosphere (chemical composition) can also be factors used to determine the appropriate block material. Alternate materials are available upon request. Please contact Honeywell Maxon for further details.

3.4 Selection table

Description	Code	Availability	
		OTTITAN-15	OTTITAN-20
Size			
1 ½"	-15	•	
2"	-20		•
Fuel			
Natural gas	N	•	•
Other fuel	X	•	•
Pilot			
Air pilot chosen	A	•	•
No pilot chosen	0	•	•
Oxy-fuel pilot chosen	O	•	•
Flame detection			
No flame sensor used	0	•	•
Provision for UV scanner (customer supplied)	1	•	•
Block material			
3000°F max service temp (Alumina/Mullite)	3	•	•
Special	X	•	•

Example

OTTITAN-15N013

Options

- EAC: If you wish EAC documents are shipped with the burner.
- Max. burner capacity: Enter the max. burner capacity within the appropriate ranges OTTITAN-15: 2–12 MBTU/h, OTTITAN-20: 10–30 MBTU/h).
- Drill size: Enter the appropriate drill size.

4 Project planning information

4.1 Combustion oxygen pressure vs. flow

OXY-THERM TITAN burners may be adjusted to operate on ratio, with excess oxygen (oxidizing environment) or with excess fuel (reducing environment). Typical applications will operate with 1-2% excess oxygen.

If burners are shut down while the furnace remains hot, it is recommended to continue a small flow of oxygen for cooling of the burner. Alternatively, air or nitrogen can be used for burner cooling during burner shut down. Total elimination of oxygen flow in hot furnaces can thermally damage burner fuel inserts and other parts. For extended shut downs in hot furnaces, it is recommended that the fuel insert be removed.

4.2 Combustion oxygen pressure - 1 1/2" burners

Imperial

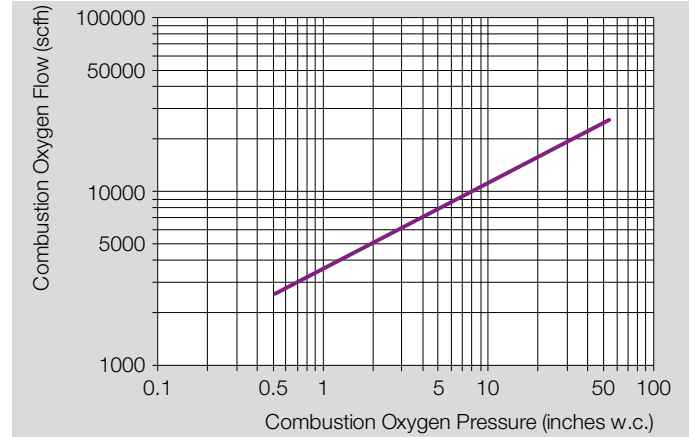

Metric

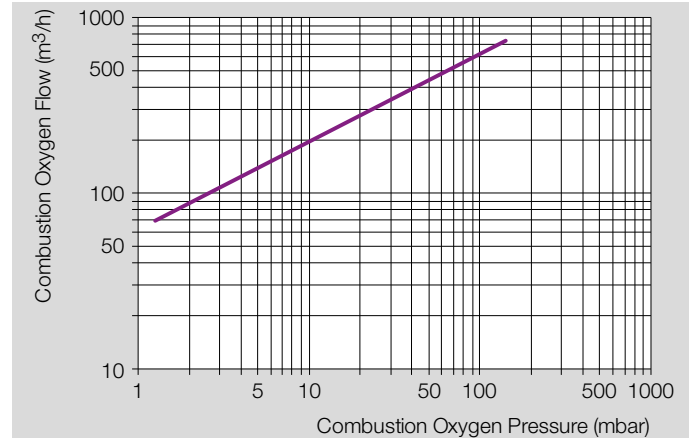

4.3 Combustion oxygen pressure – 2” burners

Imperial

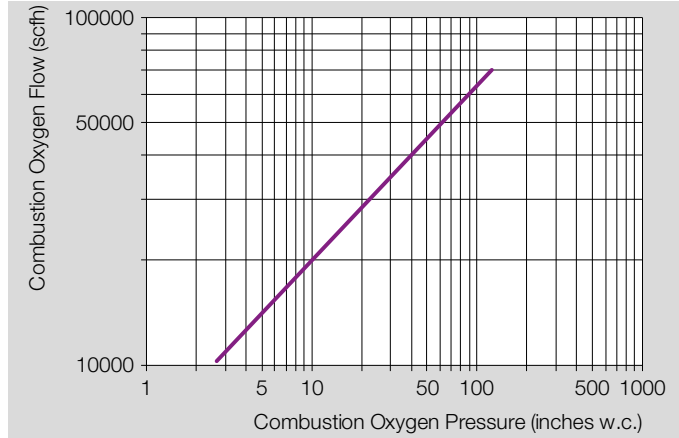

Metric

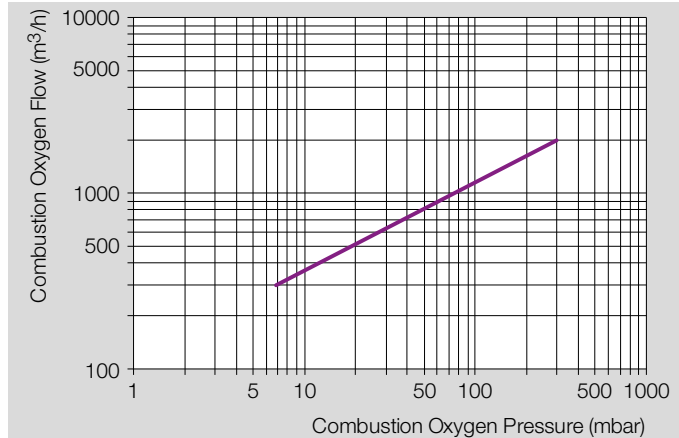

4.4 Flame lengths – 1 1/2” burners

Imperial

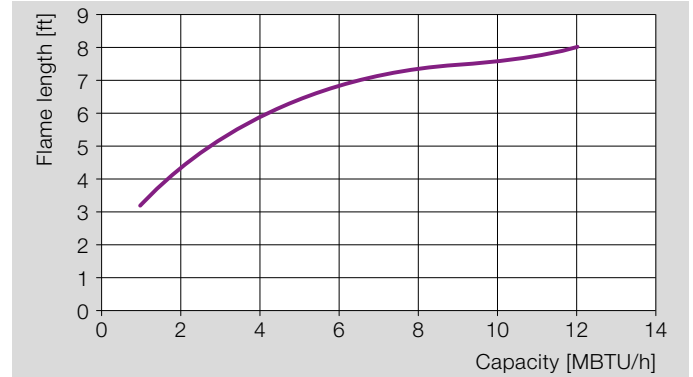

Contact Honeywell Maxon for flame length details when selecting a burner with maximum capacity below 12 MBTU/h.

Metric

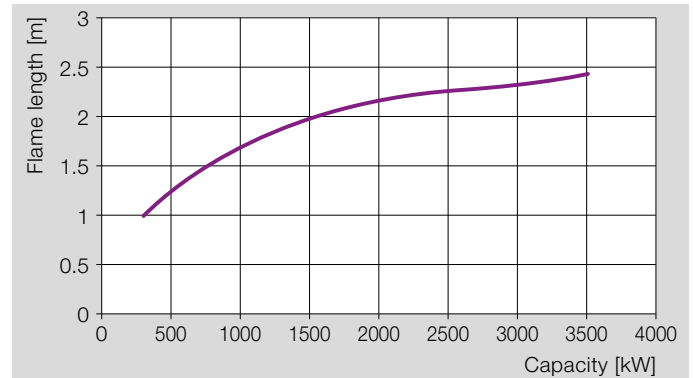

Contact Honeywell Maxon for flame length details when selecting a burner with maximum capacity below 3500 kW.

4.5 Flame lengths – 2” burners

Imperial

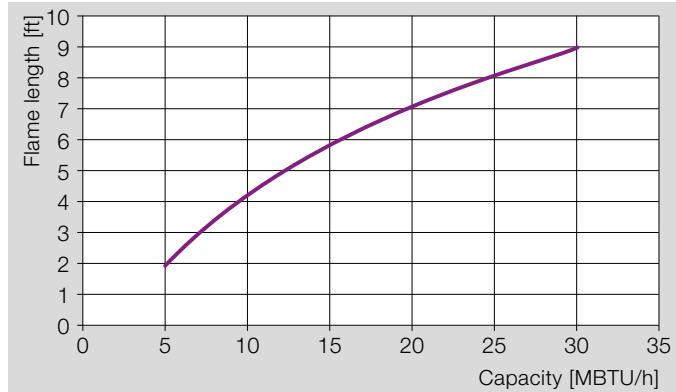

Contact Honeywell Maxon for flame length details when selecting a burner with maximum capacity below 30 MBTU/h.

Metric

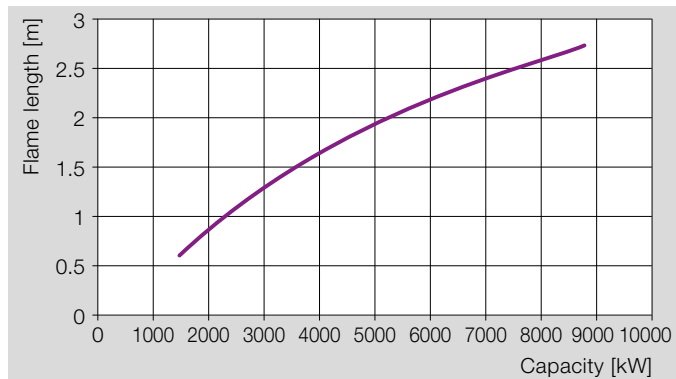

Contact Honeywell Maxon for flame length details when selecting a burner with maximum capacity below 8800 kW.

4.6 Process temperatures

The OXY-THERM TITAN burners are suitable for furnaces and melters with temperatures up to 3000°F (1649°C).

Cooling flow, either clean, dry air or oxygen, must be used whenever the burner assembly is in a high temperature atmosphere and is not firing.

4.7 Ratio control

Correct fuel/oxygen ratio control valves should be selected. Trims should be selected to enable the use with oxygen. MAXON's MICRO-RATIO valves are available with oxygen trim. For more accurate ratio control, use MAXON SMARTLINK MRV valves, or for best performance, use SMARTFIRE Intelligent Combustion Control System. Calibrated flowmeters in the fuel and the oxygen lines are recommended for establishing accurate volumetric flow rates.

4.8 Flame supervision

Flame scanning is possible down the optional flame sensing connection. Flame scanner cannot be used through pilot location to see main flame. Flame rod is not available.

4.9 Fuels

OXY-THERM TITAN burners are designed for firing on any fuel gas, including an up to 20% hydrogen/80% natural gas fuel blend.

5 Accessories

5.1 Oxy-pilot

Oxy-fuel pilot specifications

Fuel	Flow [cfh (m ³ /h)]	Pressure [inch wc (mbar)]	Capacity [Btu/h (kW)]
Natural gas	35 (1.0)	5 (12.4)	35,000 (10.3)
Propane	14 (0.4)	1.9 (4.7)	35,000 (10.3)
Oxygen	200 (5.7)	8 (19.9)	35,000 (10.3)
80 % Natural gas/20 % Hydro- gen	40.5 (1.15)	5.5 (13.7)	35,000 (10.3)
80 % Propane/20 % Hydrogen	17 (0.48)	2.3 (5.8)	35,000 (10.3)

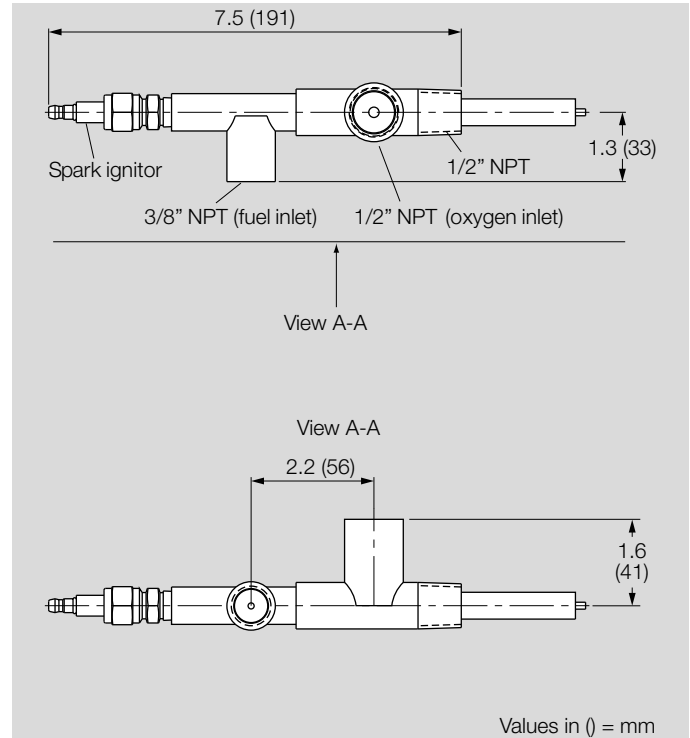

5.2 Air-fuel boosted pilot

Air-fuel boosted pilot specifications

Gas flow	Flow		Pressure		Capacity ¹⁾	
	cfh	m ³ /h	inch wc	mbar	kBTU/h	kW
Natural gas	92	2.6	10	25	92	24.3
Air	300	8.5	11	27	92	24.3

¹⁾ Capacities in BTU/h refer to the higher heating value HHV (gross calorific value). Capacities in kW refer to the lower heating value LHV.

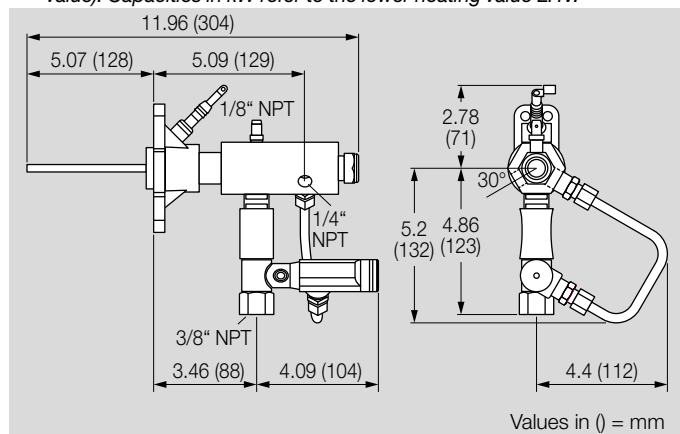

6 Technical data

6.1 Mechanical construction

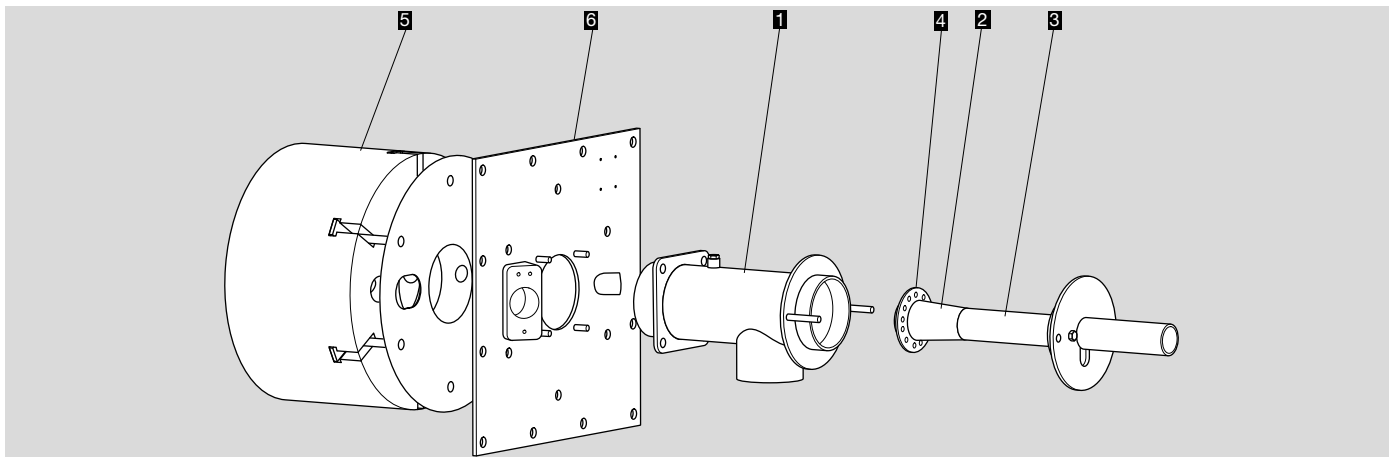

Item number	Burner part	Material
1	Housing	304 SS (1.4301)
2	Nozzle tip	310 SS (1.4841)
3	Nozzle body	304 SS (1.4301)
4	Nozzle mixing plate	310 SS (1.4841)
5	Block	Alumina/Mullite refractory
6	Mounting plate	Carbon steel

6.2 Dimensions

Imperial

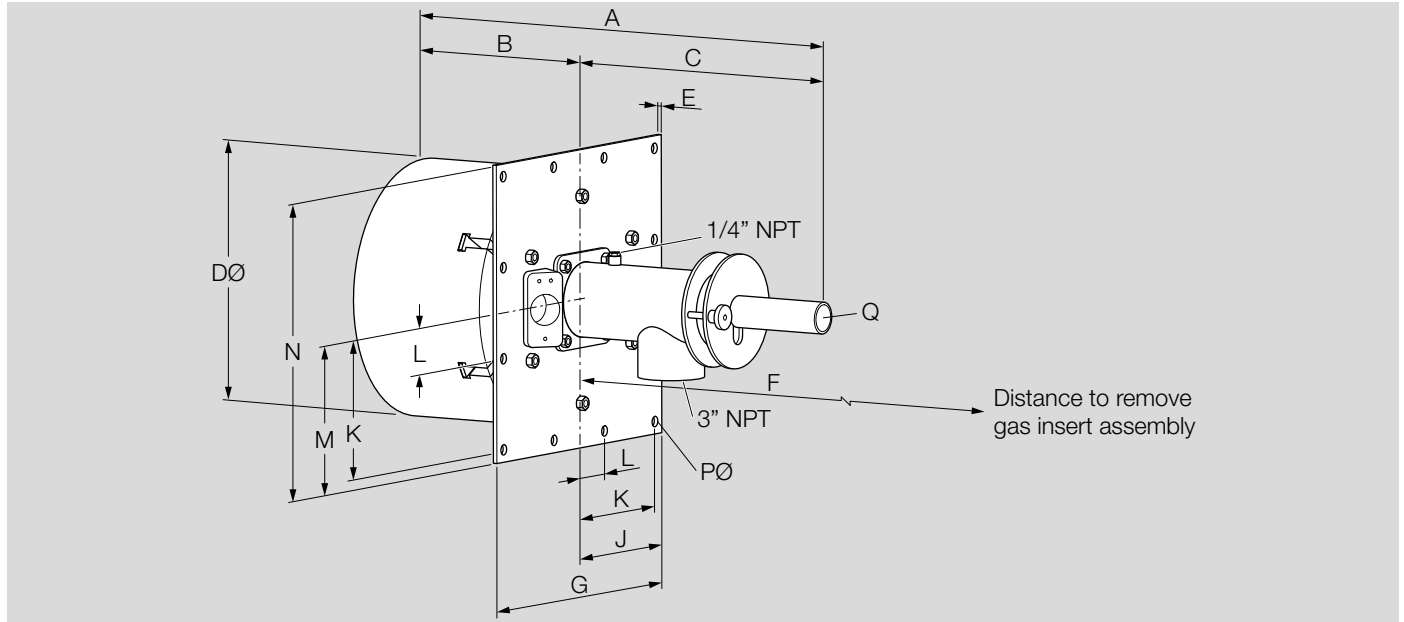

Dimensions in inches unless stated otherwise

Size	A	B	C	DØ	E	F	G	J	K	L	M	N	PØ	Q	Weight
														NPT	lbs
1 1/2"	26.68	9.06	17.62	15.5	0.25	30.5	18.0	9.0	8.25	2.75	9.0	18.0	0.625	1 1/2"	185
2"	29.5	9.06	20.44	15.5	0.25	36.0	18.0	9.0	8.25	2.75	9.0	18.0	0.625	2"	195

Metric

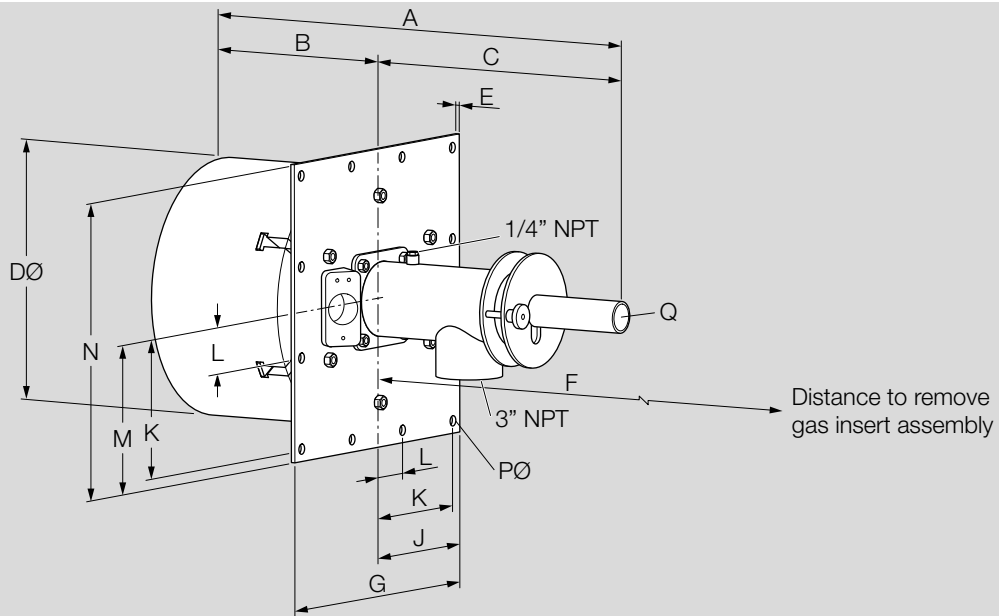

Dimensions in mm unless stated otherwise

Size	A	B	C	DØ	E	F	G	J	K	L	M	N	PØ	Q	Weight
														NPT	lbs
1 ½"	678	230	448	394	6	775	457	229	210	70	229	457	16	1 ½"	84
2"	749	230	519	394	6	914	457	229	210	70	229	457	16	2"	88

For more information

The Honeywell Thermal Solutions family of products includes Honeywell Combustion Safety, Eclipse, Exothermics, Hauck, Kromschroder and Maxon. To learn more about our products, visit ThermalSolutions.honeywell.com or contact your Honeywell Sales Engineer.

Honeywell MAXON branded products

201 E 18th Street

Muncie, IN 47302

USA

ThermalSolutions.honeywell.com

© 2022 Honeywell International Inc.

We reserve the right to make technical modifications in the interests of progress.

Honeywell

**MAXON**