

## Operating instructions Pilot burners ZMI, ZMIC

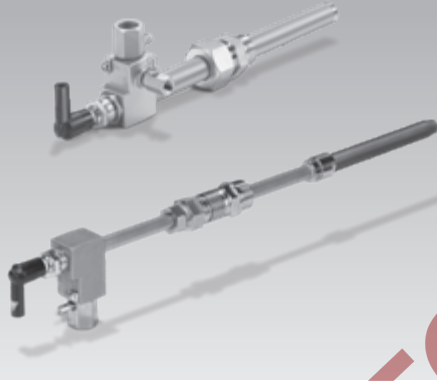

### Contents

<b>Pilot burners ZMI, ZMIC</b> .....	<b>1</b>
<b>Contents</b> .....	<b>1</b>
<b>Safety</b> .....	<b>1</b>
<b>Checking the usage</b> .....	<b>2</b>
<b>Checking the gas type</b> .....	<b>3</b>
<b>Installation</b> .....	<b>3</b>
ZMIC .....	4
ZMIC..K .....	4
<b>Wiring</b> .....	<b>4</b>
<b>Leak test</b> .....	<b>4</b>
<b>Commissioning</b> .....	<b>5</b>
ZMI .....	5
ZMIC .....	5
<b>Maintenance</b> .....	<b>5</b>
Replacing the electrode .....	5
ZMIC..K: replacing the bellows unit .....	6
ZMIC: replacing the ceramic tube .....	6
<b>Accessories</b> .....	<b>7</b>
<b>Technical data</b> .....	<b>7</b>
<b>Logistics</b> .....	<b>8</b>
<b>Declaration of Incorporation</b> .....	<b>8</b>
<b>Certification</b> .....	<b>8</b>
<b>Contact</b> .....	<b>10</b>

## Safety

### Please read and keep in a safe place



Please read through these instructions carefully before installing or operating. Following the installation, pass the instructions on to the operator. This unit must be installed and commissioned in accordance with the regulations and standards in force. These instructions can also be found at [www.docuthek.com](http://www.docuthek.com).

### Explanation of symbols

■, **1**, **2**, **3**... = Action  
> = Instruction

### Liability

We will not be held liable for damage resulting from non-observance of the instructions and non-compliant use.

### Safety instructions

Information that is relevant for safety is indicated in the instructions as follows:

#### **⚠ DANGER**

Indicates potentially fatal situations.

#### **⚠ WARNING**

Indicates possible danger to life and limb.

#### **! CAUTION**

Indicates possible material damage.

All interventions may only be carried out by qualified gas technicians. Electrical interventions may only be carried out by qualified electricians.

### Conversion, spare parts

All technical changes are prohibited. Only use OEM spare parts.

### Changes to edition 07.18

The following chapters have been changed:

- Technical data
- Logistics
- Certification

## Checking the usage

### Intended use

Ionization-controlled pilot burner for safely igniting gas burners. The capacity of the pilot burner should be 2 to 5% of that of the main burner.

Can also be used as independently operated burner. For natural gas, coke oven gas, town gas and LPG. Other types of gas on request.

This function is only guaranteed when used within the specified limits – see also page 7 (Technical data). Any other use is considered as non-compliant.

### ZMI

#### Type code

Code	Description
<b>ZMI</b>	ionization pilot with forced air supply and one electrode
<b>16–25</b>	Burner size
<b>T</b>	T-product
<b>B</b>	For natural gas
<b>G</b>	For LPG
<b>D</b>	For coke oven gas, town gas
<b>150–1000</b>	Flame tube length
<b>R</b>	Rp internal thread
<b>N</b>	NPT internal thread

#### Part designations

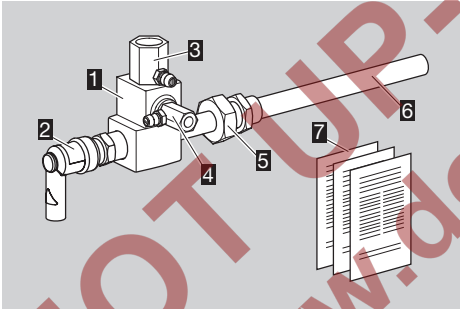

- 1** Burner housing
- 2** Interference-suppressed terminal boot with protective cap
- 3** Air nozzle
- 4** Gas nozzle
- 5** Burner bracket
- 6** Flame tube
- 7** Enclosed documentation: operating instructions and flow rate curves

Burner size, gas type, rated capacity  $P_{max}$ , flame tube length, connection – see type label.

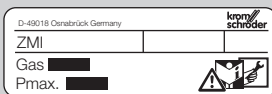

### ZMIC

#### Type code

Code	Description
<b>ZMIC</b>	ionization pilot with forced air supply, one electrode and a ceramic flame tube tip
<b>28</b>	Burner size
<b>B</b>	For natural gas
<b>G</b>	For LPG
<b>D</b>	For coke oven gas, town gas
<b>200–1000</b>	Flame tube length
<b>R</b>	Rp internal thread
<b>K</b>	Bellows unit

#### Part designations

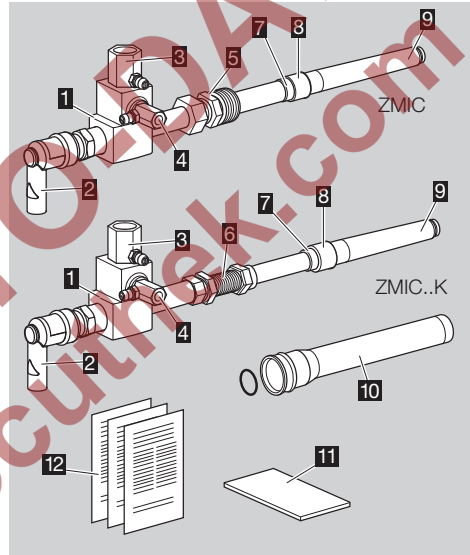

- 1** Burner housing
- 2** Interference-suppressed terminal boot with protective cap
- 3** Air nozzle
- 4** Gas nozzle
- 5** Burner bracket with reducing nipple
- 6** Bellows unit with nut
- 7** Ceramic tube retaining piece
- 8** Ceramic tube clamping ring
- 9** Ceramic tube
- 10** Transport safety device (plastic tube and O-ring)
- 11** Insulation strip
- 12** Enclosed documentation: operating instructions and flow rate curves

Burner size, gas type, rated capacity  $P_{max}$ , flame tube length, connection – see type label.



## Checking the gas type

- 1 Check if the gas nozzle diameter is suitable for the required gas type.

Gas type	Nozzle dia. [mm (inch)]		
	ZMI 16	ZMI 25	ZMIC 28
<b>B</b>	0.94 (0.037)	1.40 (0.055)	1.40 (0.055)
<b>G</b>	0.76 (0.029)	1.05 (0.041)	1.05 (0.041)
<b>D</b>	1.30 (0.051)	1.78 (0.070)	1.78 (0.070)

- ▷ When changing the nozzle, remove the residue of sealant from the burner housing.
- ▷ Suitable nozzles – see accessories.

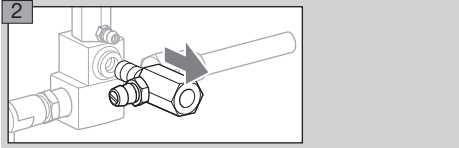

## Installation

### ⚠ DANGER

**Risk of explosion!** Ensure the connection is air-tight.

### ! CAUTION

**Burner fault!** If used as pilot burner, the gas and air pressures must be higher than the connection pressures of the main burner.

- ▷ Install the pilot burner so that reliable ignition of the main burner is guaranteed.
- ▷ Attach the pilot burner securely.
- ▷ We recommend that a filter be installed in the gas and air supply line respectively.
- ▷ Install pressure regulators and adjusting cocks in the air and gas supply lines upstream of the burner so that the air and gas pressures can be adjusted.

### ZMI

- ▷ Recommended inlet pressures:  
gas: up to 80 mbar (up to 32 °WC),  
air: up to 120 mbar (up to 47 °WC).

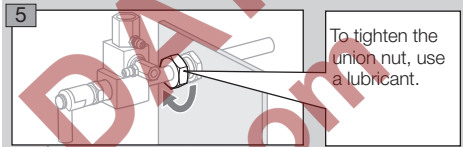
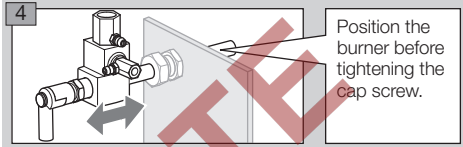
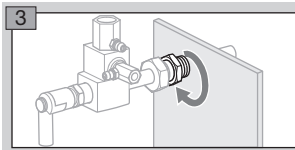
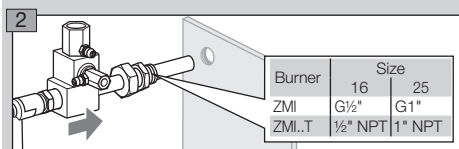
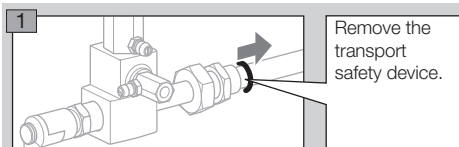

- 6 For air-tight installation, hand-tighten the union nut then tighten it with a further turn (olive fitting is secured).

- 7 Connect the pilot gas supply line with Rp ¼ and the air line with Rp ½.

### ZMIC

### ⚠ IMPORTANT

Only install the ZMIC when the burner block is cold. When installing in a hot burner block, the fibre insulation can be damaged in such a way that the burner can be thermally destroyed.

- ▷ Recommended inlet pressures:  
gas: up to 100 mbar (up to 40 °WC),  
air: up to 120 mbar (up to 47 °WC).

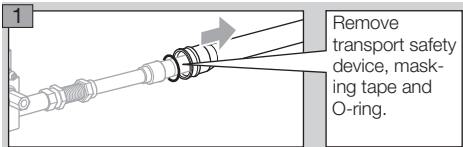

### Insulating the ceramic tube

- ▷ Protect the ceramic tube from thermal stress.
  - ▷ Insulation with enclosed insulation strips.
- 2 Compress insulation strips by wrapping adhesive foil around them tightly until they press tightly against the ceramic tube.

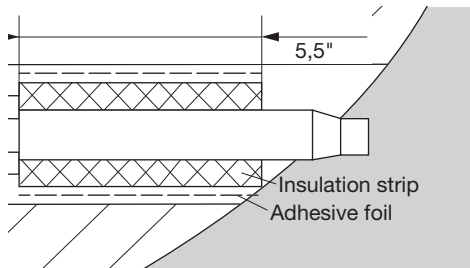

- 3 Check that the burner block hole is not blocked, e.g. using a wooden stick.

### ZMIC

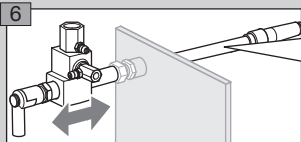
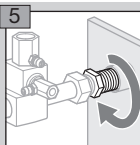
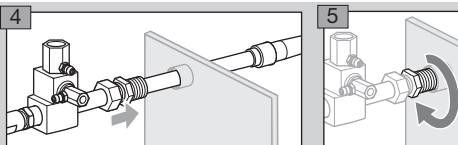

Position the burner before tightening the burner bracket.

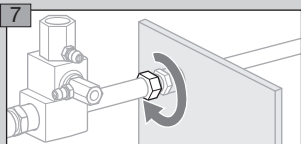

- 8 Follow the reverse procedure when dismantling.

### ZMIC..K

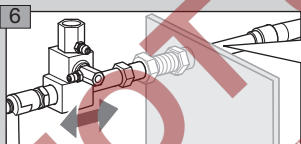
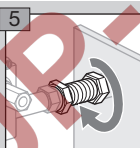
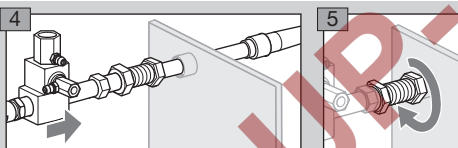

Position the burner before tightening the bellows unit nut.

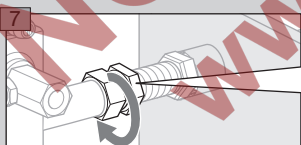

Secure the bellows unit here while tightening the bellows unit nut.

## Wiring

### **⚠ DANGER**

Electric shocks can be fatal! Before working on possible live components, ensure the unit is disconnected from the power supply.

- ▷ For the ionization and ignition cables, use un-screened high-voltage cable:
  - FZLSi 1/7 -50 to +180°C (-58 to +356°F), Order No. 04250410,
  - or
  - FZLK 1/7 -5 to +80°C (23 to 176°F), Order No. 04250409.
- ▷ Wire the burner as shown in the connection diagrams of the automatic burner control unit/ignition transformer.
- ▷ Flame control and ignition by a single electrode (single-electrode operation).

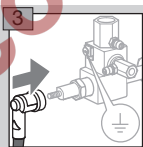
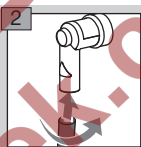
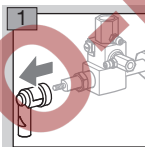

- 4 Route the PE wire directly to the automatic burner control unit.

## Leak test

### **⚠ DANGER**

**Risk of explosion and poisoning!** To ensure that there is no danger resulting from a leak, check the gas connections on the burner for leaks immediately after the burner has been put into operation.

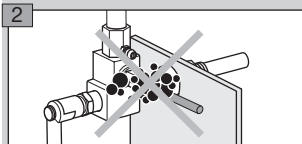
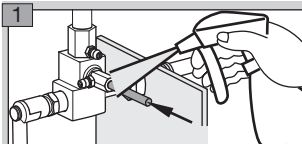

## Commissioning

### **⚠ DANGER**

**Risk of explosion!** Please observe the appropriate precautions when igniting the burners.

**Risk of poisoning!** Open the gas and air supply so that the burner is always operated with excess air – otherwise CO will form in the furnace chamber. CO is odourless and poisonous! Conduct a flue gas analysis.

- ▷ Arrange the adjustment and commissioning of the burner with the system operator or manufacturer.
- ▷ Check the entire system, upstream devices and electrical connections.
- ▷ Pre-purge the furnace chamber with air before every ignition attempt.

### **⚠ DANGER**

**Risk of explosion!** Fill the gas line to the burner carefully and correctly with gas and vent it safely into the open air – do not discharge the test volume into the furnace chamber.

- ▷ If the burner does not ignite although the automatic burner control unit has been switched on and off several times: check the entire system.
- ▷ After ignition, monitor the gas and air pressures measured on the burner and the flame. Measure the ionization current. Switch-off threshold – see automatic burner control unit operating instructions.

**1** Switch on the system.

**2** Open the manual valve.

**3** Ignite the burner via the automatic burner control unit.

**4** Adjust the burner.

- ▷ Set the ionization current by adjusting the air volume.

- ▷ The ionization current must be at least 5  $\mu\text{A}$  and must not vary.

### **⚠ DANGER**

**Risk of explosion in case of CO being formed in the furnace chamber!** An incorrect change of the burner settings may change the gas/air ratio and lead to unsafe operating conditions. CO is odourless and poisonous!

- 5** Set the pressure regulators for the gas and air supply pressures to the maximum admissible values, whereby the gas and air supply pressures should be identical.

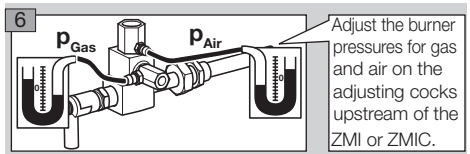

- ▷ Gas and air pressures: flow rate curves – see [www.docuthek.com](http://www.docuthek.com).

### **ZMI**

- ▷ Inlet pressure:
  - gas: up to 80 mbar (up to 32 "WC),
  - air: up to 120 mbar (up to 47 "WC).

### **ZMIC**

- ▷ Inlet pressure:
  - gas: up to 80 mbar (up to 32 "WC),
  - air: up to 120 mbar (up to 47 "WC).

## Maintenance

- ▷ We recommend an annual function check.

### **⚠ DANGER**

**Electric shocks can be fatal!** Before working on possible live components, ensure the unit is disconnected from the power supply.

**Risk of burning!** Dismantled burner components can be hot due to outflowing flue gases.

**Risk of explosion and poisoning in case of burner adjustment with an air deficiency!** Adjust the gas and air supply so that the burner is always operated with excess air – otherwise CO will form in the furnace chamber. CO is odourless and poisonous! Conduct a flue gas analysis.

**1** Check the ionization and ignition cables.

**2** Measure the ionization current.

- ▷ The ionization current must be at least 5  $\mu\text{A}$  and must not vary.

**3** Disconnect the system from the electrical power supply.

**4** Shut off the gas and air supply – do not change the restrictor settings.

**5** Check the nozzles for dirt.

### Replacing the electrode

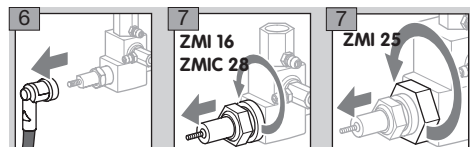

▷ Ensure that the electrode length does not change.

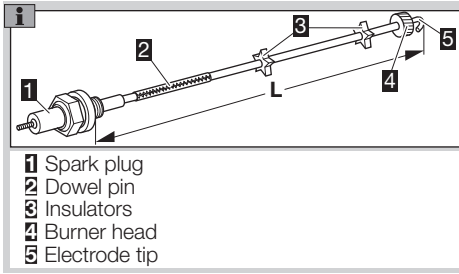

- 8** Remove dirt from electrode and insulators.  
**9** If the electrode tip or insulators are damaged, replace the electrode.

▷ Before changing the electrode, measure the total length **L**.

- 10** Connect the new electrode with the spark plug using the dowel pin.  
**11** Adjust spark plug and electrode to the measured total length **L**.  
**12** Screw the electrode into the burner housing.  
**13** Check distance **L2**:

**i** ZMI

Burner	L2	Burner	L2
ZMI 16B	25 mm	ZMI 25B	35 mm
ZMI 16D	21 mm	ZMI 25D	20 mm
ZMI 16G	25 mm	ZMI 25G	35 mm

**i** ZMIC

Burner	L2
ZMIC 28B	50 mm
ZMIC 28G	50 mm

- Reconnect the terminal boot.
- Produce a maintenance report.

### ZMIC..K: replacing the bellows unit

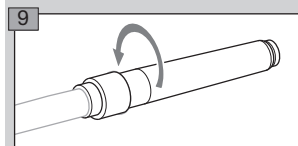
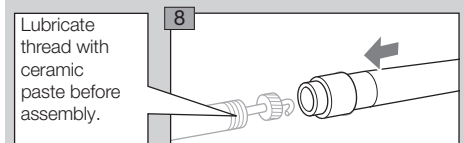
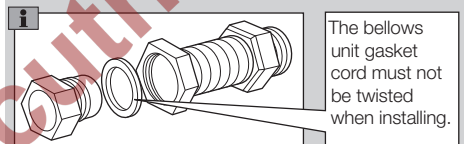
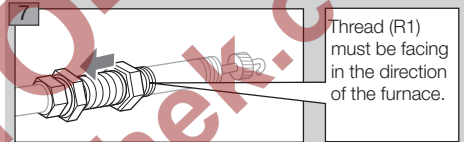
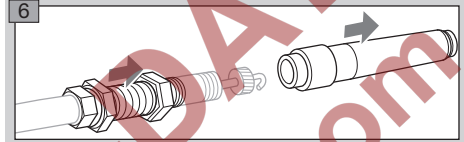
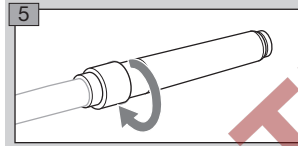
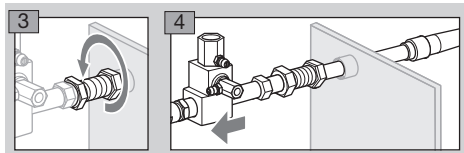
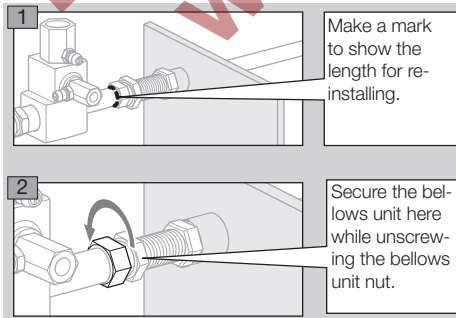

- 10** Insulate the ceramic tube and reinstall the burner, see page 3 (Installation).

### ZMIC: replacing the ceramic tube

- 1** Remove the ZMIC – see page 6 (ZMIC..K: replacing the bellows unit).

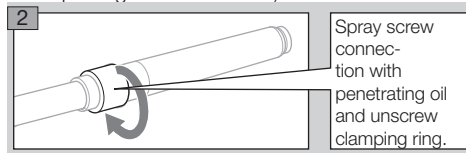

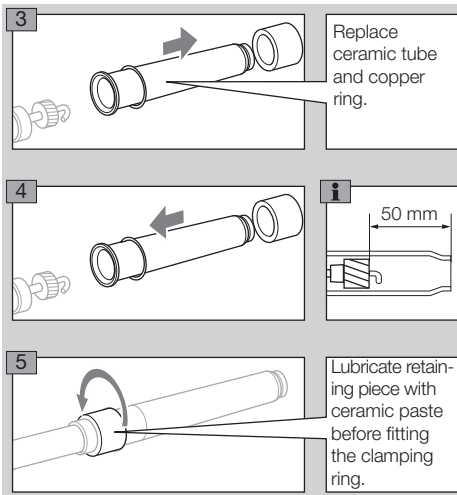

▷ Tighten the clamping ring with a torque of 30 Nm.

**6** Insulate the ceramic tube.

**7** Reinstall the burner, see page 3 (Installation).

## Accessories

### Gas nozzle

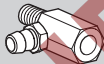

Burner	Gas type*	mm (inch)	Order No.	
			ZMI/ZMIC	ZMI..T
<b>ZMI 16</b>	<b>B</b>	0.94 (0.037)	75455010	75442157
	<b>G</b>	0.76 (0.029)	75455147	75448032
	<b>D</b>	1.30 (0.051)	75455146	–
<b>ZMI 25</b>	<b>B</b>	1.40 (0.055)	75455012	75443157
	<b>G</b>	1.05 (0.041)	75455149	75448031
	<b>D</b>	1.78 (0.070)	75455148	–
<b>ZMIC 28</b>	<b>B</b>	1.40 (0.055)	75455012	–
	<b>G</b>	1.05 (0.041)	75455149	–
	<b>D</b>	1.78 (0.070)	75455148	–

\* **B** = Natural gas

**G** = LPG

**D** = Coke oven gas, town gas

## Ceramic paste

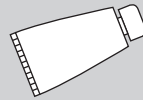

Apply ceramic paste to the screw connections after replacing any burner components in order to avoid cold-setting.

Order number: 05012009.

## Technical data

### Ambient conditions

Protect the unit from precipitation, dirt and dust, e.g. with a protective housing.

Do not allow any icing, condensation or dew in and on the ZMI.

Avoid direct sunlight or radiation from red-hot surfaces on the unit. Note the maximum medium and ambient temperatures!

Avoid corrosive influences, e.g. salty ambient air or SO<sub>2</sub>.

The unit may be stored and installed outdoors in the specified ambient conditions as long as a weather protection cover is used.

Ambient, transport and storage temperature: -15 to +60°C.

This unit is not suitable for cleaning with a high-pressure cleaner and/or cleaning products.

### Mechanical data

Gas types: natural gas, LPG (gaseous), coke oven gas, town gas and clean cold air.

#### ZMI

Capacity:

ZMI 16: 1 to 2 kW (3.8 to 7.6 10<sup>3</sup> BTU/h),  
ZMI 25: 2.5 to 4 kW (9.5 to 15.1 10<sup>3</sup> BTU/h)

(1.5 to 3.3 kW when used with coke oven gas, town gas).

Capacities in kW refer to the lower heating value H<sub>l</sub> and capacities in BTU/h refer to the higher heating value H<sub>o</sub> (gross calorific value).

Gas inlet pressure: 15 to 70 mbar (6 to 27 "WC),  
air inlet pressure: 15 to 90 mbar (6 to 35 "WC),  
each depending on the gas type (burner pressures – see www.docuthek.com, Type of document:

Flow rate curve).

Burner length increments: 100 mm (4").

Housing: aluminium.

Flame tube: heat-resistant steel.

Max. temperature at the tip of the flame tube:

< 1000°C (< 1832°F),

< 900°C (< 1652°F) for lambda < 1.

#### ZMIC

Capacity:

2.5 to 4.2 kW (9.5 to 15.9 10<sup>3</sup> BTU/h).

Capacities in kW refer to the lower heating value H<sub>l</sub> and capacities in BTU/h refer to the higher heating value H<sub>o</sub> (gross calorific value).

Gas inlet pressure: up to 100 mbar (up to 40 "WC),  
air inlet pressure: up to 120 mbar (up to 47 "WC),  
each depending on the gas type (burner pressures  
– see [www.docuthek.com](http://www.docuthek.com), Type of document:  
Flow rate curve).

Burner length increments: 100 mm (4"),  
length increments of the ZMIC 28..K: 50 mm (2").

Housing: aluminium.

Flame tube: ceramic flame tube.

Max. temperature at the tip of the flame tube:  
1450°C (2642°F).

### Electrical data

Control: with flame rod.

Ignition: direct spark ignition (5 kV ignition trans-  
former).

### ZMI

Right-angle terminal boot: interference-sup-  
pressed.

### ZMIC

Spark electrode terminal boot: interference-  
suppressed.

## Logistics

### Transport

Protect the unit from external forces (blows, shocks,  
vibration).

Transport temperature: see page 7 (Technical  
data).

Transport is subject to the ambient conditions de-  
scribed.

Report any transport damage on the unit or packag-  
ing without delay.

Check that the delivery is complete, see page 2  
(Part designations).

### Storage

Storage temperature: see page 7 (Technical data).  
Storage is subject to the ambient conditions de-  
scribed.

Storage time: 2 years before using for the first time.  
If stored for longer than this, the overall service life will  
be reduced by the corresponding amount of extra  
storage time.

### Packaging

The packaging material is to be disposed of in ac-  
cordance with local regulations.

## Contact

If you have any technical questions, please contact  
your local branch office/agent. The addresses are  
available on the Internet or from Elster GmbH.

We reserve the right to make technical modifications  
in the interests of progress.

### Disposal

Components are to be disposed

## Declaration of Incorporation

pursuant to 2006/42/EC, Annex II, No. 1B

The products "Burners for gas ZMI and ZMIC" are  
partly completed machines pursuant to Article 2g and  
are designed exclusively for installation in or assembly  
with another machine or other equipment.

The following essential health and safety requirements  
in accordance with Annex I of this Directive are ap-  
plicable and have been fulfilled:

Annex I, Articles 1.1.3, 1.1.5, 1.3.2, 1.3.4, 1.5.2,  
1.7.4, 1.5.10

The relevant technical documentation pursuant to  
Annex VII B has been produced and will be transmit-  
ted to the competent national authorities in electronic  
form on request.

The following (harmonized) standards have been  
applied:

- EN 746-2:2010 – Industrial thermoprocessing  
equipment – Safety requirements for combustion  
and fuel handling systems
- EN ISO 12100:2010 – Safety of machinery – Gen-  
eral principles for design – Risk assessment and  
risk reduction (ISO 12100:2010)

The partly completed machine may only be com-  
missioned once it has been established that the  
machine where the product mentioned above is to  
be incorporated complies with the provisions of the  
Machinery Directive 2006/42/EC.

Elster GmbH

Scan of the Declaration of Incorporation (D, GB) – see  
[www.docuthek.com](http://www.docuthek.com)

## Certification

### Eurasian Customs Union



The product ZMI, ZMIC meets the technical specifi-  
cations of the Eurasian Customs Union.

# Honeywell

**krom/  
schroder**

Elster GmbH

Strotheweg 1, D-49504 Lotte (Büren)

Tel. +49 541 1214-0

Fax +49 541 1214-370

[hts.lotte@honeywell.com](mailto:hts.lotte@honeywell.com), [www.kromschroeder.com](http://www.kromschroeder.com)