

Eclipse

Metering Orifice Systems

Series FOM

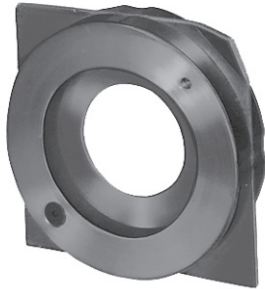

Basic FOM



FOM with Flanges

Easy installation
Rugged construction
Complete line of sizes
Accurate and inexpensive
Monitoring accessories available



FOM with Hose Cocks



FOM with Pressure Gauge

Eclipse flanged metering orifices are designed to be installed in the supply piping of combustion systems to measure air or gas flow to burners.

Metering orifice systems can be used to balance flows to burners and monitor air/gas ratios. Through careful use of orifice meters, combustion systems can be adjusted for maximum fuel economy.

3/4" through 2" metering orifice assemblies include an orifice plate, two pressure tap plates, gaskets, pipe flanges, and bolts. Larger sizes consist of a basic assembly containing an orifice plate, two pressure tap plates, and gaskets only; a flange kit must be ordered

separately. Five standard orifice plate bores are available for each pipe size, and Eclipse can supply other bores on special order. Hose fitting and pressure gauge kits are available to complete the metering orifice system.

Although metering orifice bodies will withstand pressures to 125 psig, hose cocks and differential pressure gauges have maximum inlet pressure ratings of 15 psig. Ambient temperatures must not exceed 140°F. For higher pressures and temperatures, contact Eclipse. Standard differential pressure gauges are calibrated in inches water column with a maximum differential of 10" w.c. Other calibrations or higher differentials are available on special order.

Orifice Selection

For good readability of differential pressures, orifices should be sized to give a minimum of 2" w.c. ΔP at maximum flow rate. If sufficient pressure is available, size for the highest ΔP the system will tolerate. (Do not exceed 20" w.c. ΔP . If higher ΔP 's required, consult factory.)

To select an orifice, proceed as follows:

1. Determine maximum flow rate.
2. Determine specific gravity of gas.
3. Determine temperature of gas.
4. Determine pressure of gas at orifice location.
5. Determine maximum pressure loss your system can tolerate.
6. From the correction tables select a factor to obtain corrected maximum flow.
7. Divide maximum flow rate by each factor to obtain corrected maximum flow.
8. Using the corrected maximum flow, refer to the selection chart's maximum pressure loss selected (step 5). Read down to first flow rating which equals or exceeds the corrected flow, then left to the orifice size.
9. If maximum corrected flow rate using next larger orifice is less than 2" w.c., a special size orifice is required. Consult factory.

EXAMPLE: (Note: Steps 1 thru 9 in example will refer back to numbers 1 thru 9 in "Orifice Selection".)

300,000 BTU burner using natural gas at 2 psig. From correction charts S.G. = 0.60, SCFH Gas Flow = 300,000/1000 (BTU/C.F.) = 300 SCFH. Assume 60°F temperature.

1. 300 SCFH
2. 0.60 S.G.
3. 60°F
4. 2 psig
5. Assume 6" w.c.
6. S.G. factor = 1.29, Temperature factor = 1.00, Pressure factor = 1.03.
7. $300 / 1.29 / 1.00 / 1.03 = 226$ CFH corrected maximum flow.
8. Locate 6" w.c. at the top of the chart and read down. The first flow which equals or exceeds 226 cfh is 281 cfh, which corresponds with the 3-4 FOM (3/4" pipe size). Actual high fire drop through this orifice will be about 4" w.c. (229 cfh). If you prefer a larger gas line size, 1" w.c., read down further. The 4-2 FOM (276 cfh @ 6" w.c.) will also suffice.
9. Does not apply in this example.

Temperature Correction Factors

Temp °F	50	60	70	80	90	100	110	120	130	140	150	160	170	180	190	200
Factor	1.01	1.00	0.99	0.98	0.97	0.96	0.95	0.94	0.94	0.93	0.92	0.92	0.91	0.90	0.89	0.88

Specific Gravity Correction Factors

Specific Gravity	0.40	0.50	0.60	0.70	0.80	0.90	1.00	1.10	1.20	1.30	1.40	1.50	1.60	1.70	1.80	1.90	2.00
Factor	1.58	1.41	1.29	1.20	1.12	1.05	1.00	0.95	0.91	0.88	0.85	0.82	0.79	0.77	0.75	0.73	0.71

Pressure Correction Factors (Sea Level)

Press. PSIG	0.5	1	2	3	4	5	6	7	8	9	10	11	12	13	14	15
Factor	0.98	1.00	1.03	1.06	1.09	1.12	1.15	1.18	1.20	1.23	1.25	1.28	1.30	1.33	1.35	1.37

Specific Gravity and BTU Content of Various Gases

Types of Gas	S.G.	BTU/CF	CF Air Required Per CF Gas
Natural	0.60	1000	10
Propane	1.56	2500	24
Butane	2.00	3300	30
Coke Oven	0.45	500	5

Selection Chart

Pipe Size	Orifice Meter	Differential Pressure, "w.c. Across Orifice Taps for SCFH Air														
		1	2	3	4	5	6	7	8	9	10	12	14	16	18	20
3/4"	3-1 FOM	39	56	68	79	88	97	104	111	118	125	137	147	158	167	176
	3-2 FOM	56	79	97	112	125	137	148	158	168	177	194	210	224	238	251
	3-3 FOM	80	113	138	160	179	196	211	226	240	253	277	299	320	339	357
	3-4 FOM	115	162	198	229	256	281	303	324	344	362	397	429	458	486	512
	3-5 FOM	170	240	290	330	370	410	440	470	500	530	580	620	670	710	740
1"	4-1 FOM	79	112	137	158	177	194	210	224	238	250	274	296	317	336	354
	4-2 FOM	113	159	195	225	252	276	298	318	338	356	390	421	450	477	503
	4-3 FOM	160	230	280	320	360	390	420	450	480	510	560	600	640	680	720
	4-4 FOM	230	330	400	470	520	570	620	660	700	740	810	870	930	990	1040
	4-5 FOM	340	490	600	690	770	840	910	970	1030	1090	1190	1290	1370	1460	1540
1-1/4"	5-1 FOM	160	220	270	320	350	390	420	450	470	500	550	590	630	670	710
	5-2 FOM	230	320	390	450	500	550	600	640	680	710	780	840	900	960	1010
	5-3 FOM	320	460	560	650	720	790	860	920	970	1020	1120	1210	1290	1370	1450
	5-4 FOM	470	670	820	940	1050	1150	1250	1330	1410	1490	1630	1760	1880	2000	2110
	5-5 FOM	710	1000	1230	1420	1580	1740	1870	2000	2130	2240	2450	2650	2830	3010	3170
1-1/2"	6-1 FOM	220	320	390	450	500	550	590	630	670	710	780	840	900	950	1000
	6-2 FOM	320	450	550	640	710	780	840	900	960	1010	1110	1190	1280	1350	1430
	6-3 FOM	460	650	790	920	1020	1120	1210	1300	1370	1450	1590	1710	1830	1940	2050
	6-4 FOM	670	950	1160	1340	1500	1640	1770	1900	2101	2120	2320	2510	2680	2840	3000
	6-5 FOM	1010	1430	1750	2020	2260	2480	2670	2860	3030	3200	3500	3780	4040	4290	4520
2"	8-1 FOM	320	450	550	630	710	770	840	890	950	1000	1090	1180	1260	1340	1410
	8-2 FOM	450	640	780	900	1000	1100	1190	1270	1350	1420	1560	1680	1800	1910	2010
	8-3 FOM	640	910	1110	1290	1440	1580	1700	1820	1930	2030	2230	2410	2570	2730	2880
	8-4 FOM	930	1320	1610	1860	2080	2280	2460	2630	2790	2940	3230	3480	3720	3950	4160
	8-5 FOM	1380	1950	2390	2760	3090	3380	3660	3910	4150	4370	4790	5170	5530	5860	6180
3"	12-1 FOM	920	1300	1590	1830	2050	2240	2420	2590	2750	2900	3170	3430	3660	3890	4100
	12-2 FOM	1310	1860	2280	2630	2940	3220	3480	3720	3940	4160	4550	4920	5260	5580	5880
	12-3 FOM	1900	2700	3300	3800	4200	4600	5000	5300	5700	6000	6500	7000	7500	8000	8400
	12-4 FOM	2800	3900	4800	5500	6200	6800	7300	7800	8300	8700	9600	10300	11100	11700	12400
	12-5 FOM	4300	6000	7400	8600	9600	10500	11300	12100	12800	13500	14800	16000	17100	18100	19100
4"	16-1 FOM	1800	2600	3200	3700	4100	4500	4900	5200	5500	5800	6400	6900	7300	7800	8200
	16-2 FOM	2600	3700	4500	5200	5900	6400	6900	7400	7900	8300	9100	9800	10500	11100	11700
	16-3 FOM	3800	5400	6600	7700	8600	9400	10100	10800	11500	12100	13300	14400	15300	16300	17200
	16-4 FOM	5800	8100	10000	11500	12900	14100	15200	16300	17300	18200	19900	21500	23000	24400	25700
	16-5 FOM	9000	12700	15600	18000	20100	22000	23800	25500	27000	28500	31200	33700	36000	38200	40300
6"	24-1 FOM	3700	5200	6400	7300	8200	9000	9700	10400	11000	11600	12700	13700	14700	15600	16400
	24-2 FOM	5300	7400	9100	10500	11800	12900	13900	14900	15800	16600	18200	19700	21000	22300	23500
	24-3 FOM	7500	10700	13100	15100	16900	18500	20000	21400	22600	23900	26100	28200	30200	32000	33800
	24-4 FOM	11200	15900	19400	22400	25100	27500	29700	31700	33700	35500	38900	42000	44900	47600	50200
	24-5 FOM	17000	24000	30000	34000	39000	42000	46000	49000	52000	55000	60000	65000	69000	73000	77000
8"	32-1 FOM	7300	10400	12700	14700	16400	18000	19400	20800	22000	23200	25400	27500	29400	31100	32800
	32-2 FOM	10600	15000	18300	21200	23700	25900	28000	30000	31800	33500	36700	39600	42400	44900	47400
	32-3 FOM	15000	22000	27000	31000	34000	38000	41000	43000	46000	49000	53000	58000	61000	65000	69000
	32-4 FOM	23000	33000	40000	46000	52000	57000	61000	65000	69000	73000	80000	87000	92000	98000	103000
	32-5 FOM	36000	51000	63000	73000	81000	89000	96000	103000	109000	115000	126000	136000	145000	154000	162000
10"	40-1 FOM	21000	30000	36000	42000	47000	51000	56000	59000	63000	66000	73000	79000	84000	89000	94000
	40-2 FOM	27000	38000	47000	54000	60000	66000	71000	76000	81000	85000	94000	101000	108000	115000	121000
	40-3 FOM	34000	49000	59000	69000	77000	84000	91000	97000	103000	108000	119000	128000	137000	146000	153000
	40-4 FOM	45000	64000	78000	90000	100000	110000	119000	127000	135000	142000	156000	168000	180000	191000	201000
	40-5 FOM	56000	80000	98000	113000	126000	138000	149000	160000	169000	179000	196000	211000	226000	240000	253000

= Piping velocity pressures exceed .5" w.c. at these flows. For good piping practices, Eclipse recommends velocity pressures below .5" w.c.

Dimensions

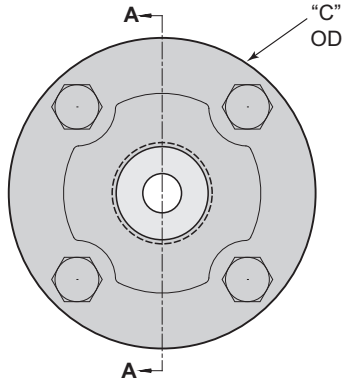

- Basic assembly included with all meters.
- Flanges included with 3/4" through 2" meters. A flange kit must be ordered separately for larger sizes

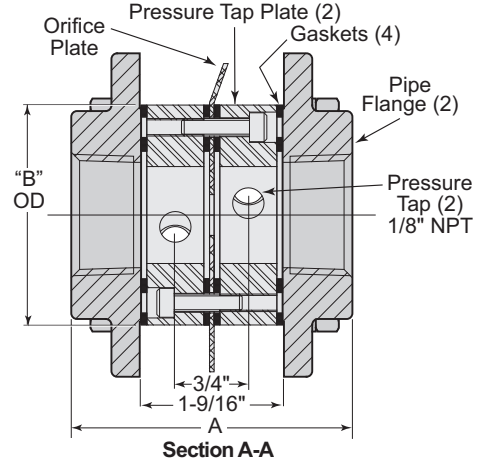

Pipe Size	Cat. No.	Orifice Dia.	Asy. No.	Flange Kit	Hose Fitting Parts Kit*	Flow Meter Parts Kit**	Dimensions in Inches		
							A	B	C
3/4"	3-1 FOM	0.221	302072-1	-			3-1/16"	2-3/8"	3-1/2"
	3-2 FOM	0.263	302072-2	-					
	3-3 FOM	0.313	302072-3	-	302053	302057			
	3-4 FOM	0.372	302072-4	-					
	3-5 FOM	0.442	302072-5	-					
1"	4-1 FOM	0.313	302084-1	-			3-1/16"	2-3/8"	3-1/2"
	4-2 FOM	0.372	302084-2	-					
	4-3 FOM	0.442	302084-3	-	302053	302057			
	4-4 FOM	0.526	302084-4	-					
	4-5 FOM	0.625	302084-5	-					
1-1/4"	5-1 FOM	0.442	302085-1	-			3-1/16"	2-3/8"	3-1/2"
	5-2 FOM	0.526	302085-2	-					
	5-3 FOM	0.625	302085-3	-	302053	302057			
	5-4 FOM	0.743	302085-4	-					
	5-5 FOM	0.884	302085-5	-					
1-1/2"	6-1 FOM	0.526	302086-1	-			3-1/2"	3-11/16"	5"
	6-2 FOM	0.625	302086-2	-					
	6-3 FOM	0.743	302086-3	-	302053	302057			
	6-4 FOM	0.884	302086-4	-					
	6-5 FOM	1.051	302086-5	-					
2"	8-1 FOM	0.625	302087-1	-			3-1/2"	3-11/16"	5"
	8-2 FOM	0.743	302087-2	-					
	8-3 FOM	0.884	302087-3	-	302053	302057			
	8-4 FOM	1.051	302087-4	-					
	8-5 FOM	1.250	302087-5	-					
3"	12-1 FOM	1.062	302050-1	302054			4-1/16"	5-1/4"	7-1/2"
	12-2 FOM	1.266	302050-2	302054					
	12-3 FOM	1.500	302050-3	302054	302053	302057			
	12-4 FOM	1.781	302050-4	302054					
	12-5 FOM	2.125	302050-5	302054					
4"	16-1 FOM	1.500	302051-1	302055			4-3/16"	6-1/4"	9"
	16-2 FOM	1.781	302051-2	302055					
	16-3 FOM	2.125	302051-3	302055	302067	302066			
	16-4 FOM	2.531	302051-4	302055					
	16-5 FOM	3.000	302051-5	302055					
6"	24-1 FOM	2.125	302052-1	302056			4-11/16"	8"	11"
	24-2 FOM	2.531	302052-2	302056					
	24-3 FOM	3.000	302052-3	302056	302067	302066			
	24-4 FOM	3.578	302052-4	302056					
	24-5 FOM	4.250	302052-5	302056					
8"	32-1 FOM	3.000	302064-1	302065			5-1/16"	9-1/2"	13-1/2"
	32-2 FOM	3.578	302064-2	302065					
	32-3 FOM	4.250	302064-3	302065	302067	302066			
	32-4 FOM	5.062	302064-4	302065					
	32-5 FOM	6.000	302064-5	302065					
10"	40-1 FOM	5.000	302068-1	302071			5-3/4"	11-3/4"	16"
	40-2 FOM	5.600	302068-2	302071					
	40-3 FOM	6.200	302068-3	302071	302069	302070			
	40-4 FOM	6.900	302068-4	302071					
	40-5 FOM	7.500	302068-5	302071					

* Hose Fitting Parts Kit Includes: (2) 1/8" x 1/8" lever handle gas cocks, (2) 1/8" hose fittings and (2) 1/8" pipe nipples.

** Flow Meter Parts Kit Includes: differential gauge, (2) 1/8" x 1/8" lever handle gas cocks and necessary fittings, nipples, and tubing. The default range of the differential gauge is 0 - 10" w.c. and is recommended for air only. Contact Eclipse for configurations that require combustible gases.