

Eclipse Extern-A-Therm Recuperators

Model 600 MA

Parameter		Specification*
Recuperator	Maximum Input	700,000 BTU/hr (205 kW)
	Maximum Exhaust Temperature with No Combustion Air	1800°F (1000°C)
	Maximum Exhaust Temperature with 180 scfh Combustion Air	2100°F (1150°C)
	Air Pressure Drop at Maximum Input	16.0" w.c. (40 mbar)
	Exhaust Pressure Drop at Maximum Input	0.55" w.c. (1.27 mbar)
	Maximum Allowable Air Pressure	3 psig (200 mbarg)
	Weight of Recuperator	82.5 lbs (38 kg)
Eductor	Suction at Maximum Input	0.75" w.c. (1.9 mbar)
	Entrainment Air Volume at Maximum Input	6,000 scfh (170 Nm ³ /hr)
	Entrainment Air Pressure at Eductor Inlet at Maximum Input	20" w.c. (50 mbar)
	Weight of Eductor	65 lbs (30 kg)
Exhaust Housing	Weight of Exhaust Housing	48 lbs (22 kg)

* See Design Guide 540 for application specific operational limitations.

- All inputs based upon gross calorific values.
- Eclipse reserves the right to change the construction and/or configuration of our products at any time without being obliged to adjust earlier supplies accordingly.

Percent Fuel Savings at Various Furnace Exhaust Temperatures & Combustion Air Preheats (10% Excess Air)

Furnace Exhaust Temperature °F (°C)	Preheated Air Temperature °F (°C)				
	700 (370)	800 (425)	900 (480)	1000 (540)	1100 (590)
2400 (1315)	29%	32%	35%	38%	41%
2200 (1200)	26%	29%	31%	34%	36%
2000 (1090)	23%	26%	28%	31%	33%
1800 (980)	21%	23%	26%	28%	31%
1600 (870)	19%	22%	24%	26%	28%
1400 (760)	18%	20%	22%	24%	26%
1200 (650)	17%	19%	21%	23%	25%
1000 (540)	15%	18%	20%	-	-

Specifications

600 M Extern-A-Therm Preheated Air Temperature

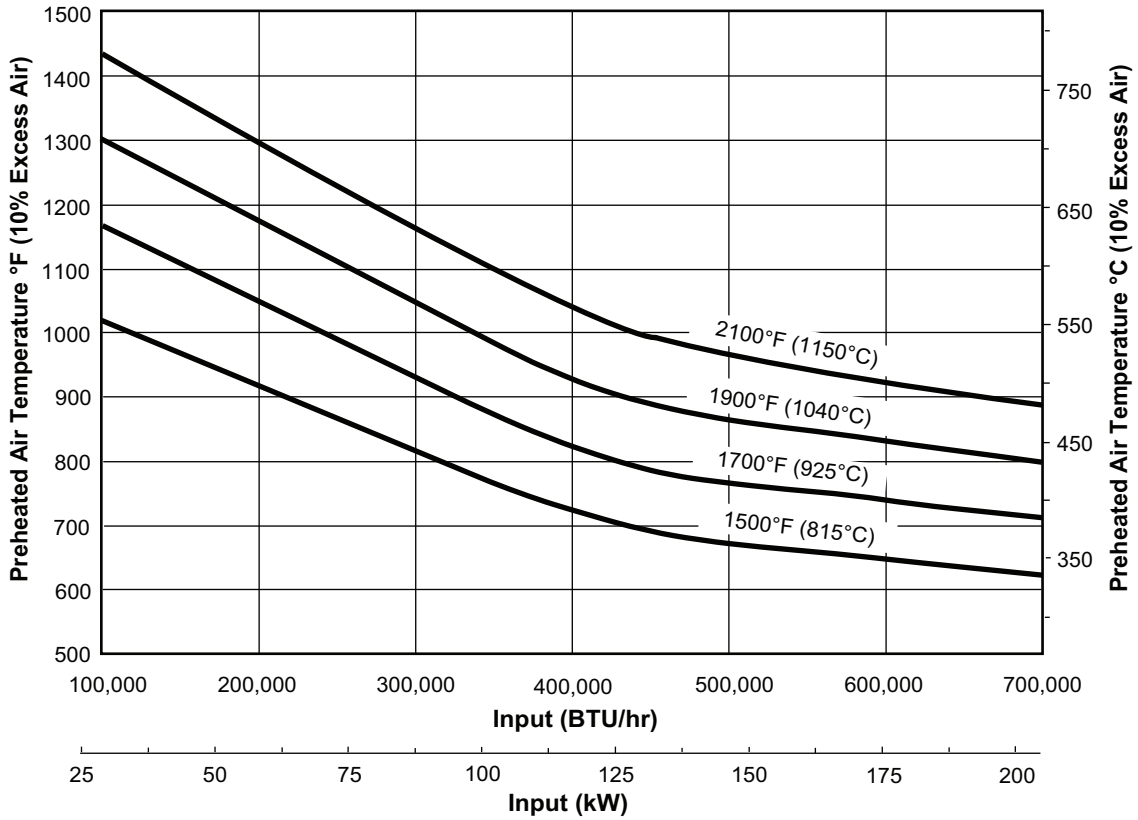

ΔP 600 Extern-A-Therm with 1900°F (1040°C) Exhaust

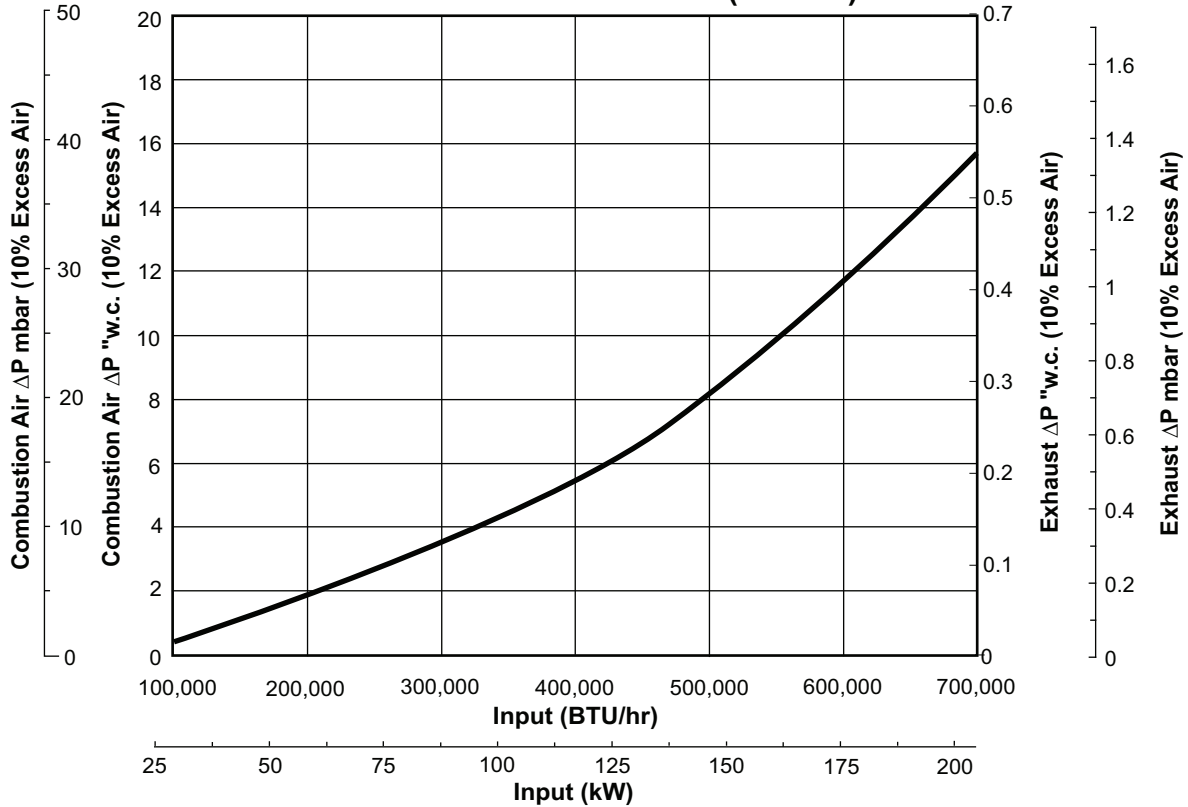

Dimensions in inches (mm)

600MA Recuperator

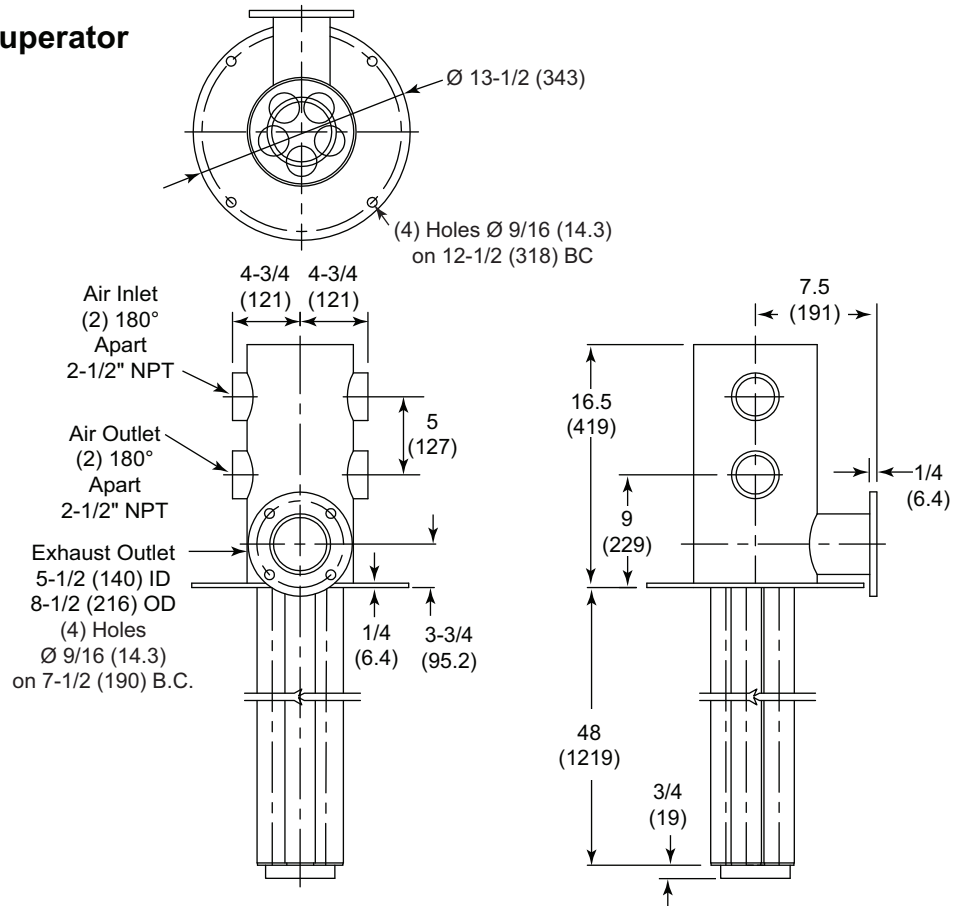

600EA Eductor

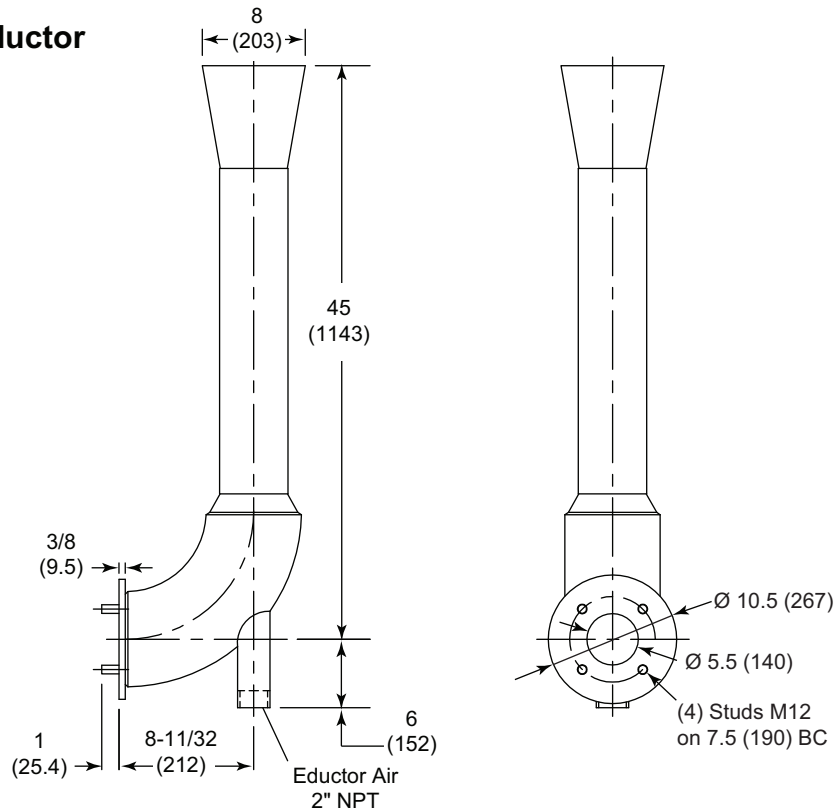

Dimensions in inches (mm)

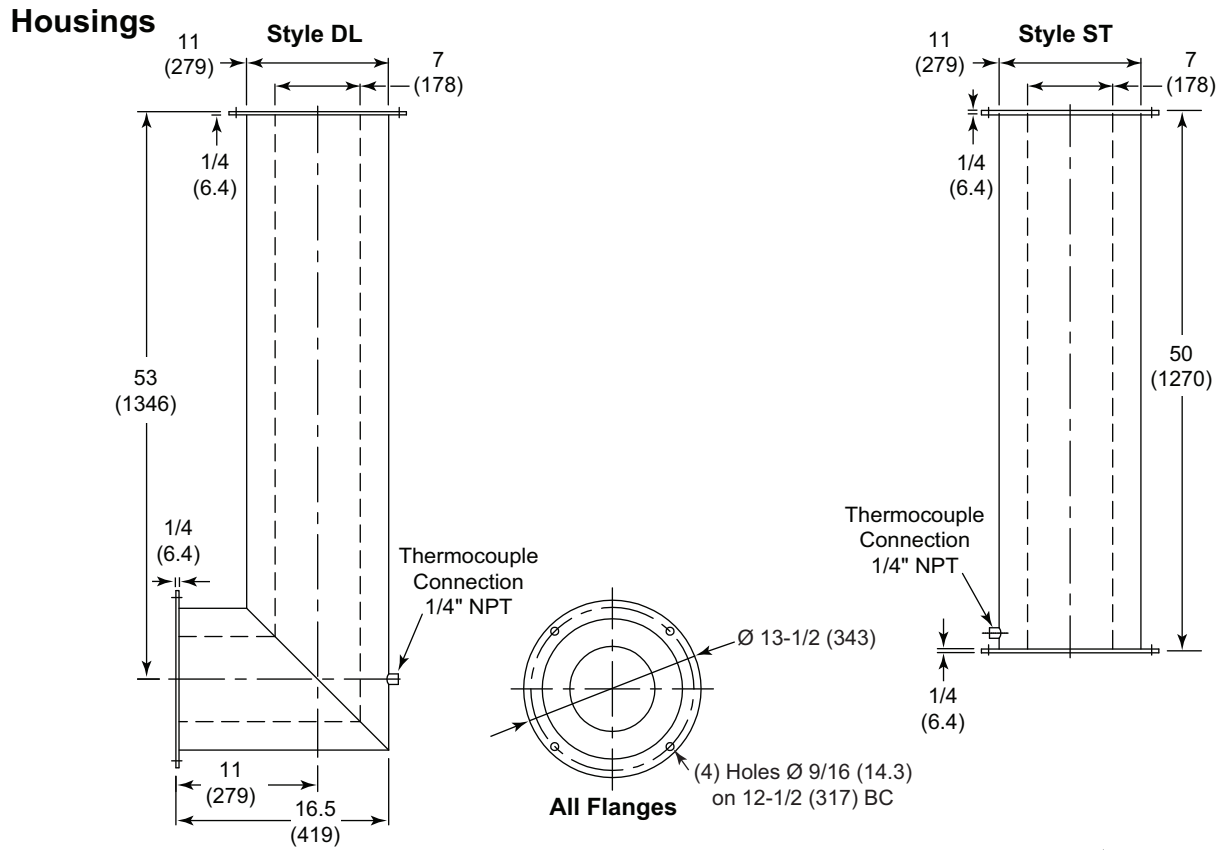

Typical Applications

