

# Eclipse AH-MA DualBlock

## Burners

Model DB1600T

Version 1

Parameter	Specifications
Maximum Input, Btu/h (kW)	16,000,000 (4800)
Nominal Input, Btu/h (kW)	8,000,000 (2400)
Minimum Input, Btu/h (kW)	400,000 (120)
Excess Air Flow	1.5 to 3.0
Standard Regulation (maximum)	20:1 (40:1)
Chamber Pressure, "w.c. (mbar)	-2.41 to 1.60 (-6 to 4)
Maximum Temperature Rise, °F (°C)	752 (400)
Duct Process Velocity ft/s (m/s)	16.4 to 66 (5 to 20)
Ignition	Spark Ignited Pilot
Built-in Pilot	Interruptible Pilot for Natural Gas, Propane or Butane
Gas Pilot Pressure dP, "w.c. (mbar)	Natural Gas: 0.6 to 1.2 (1.5 to 3.0) Propane: 0.25 to 0.5 (0.6 to 1.2) Butane: 0.2 to 0.4 (0.5 to 1.0)
Gas Pilot Input, Btu/h (kW)	25,000 to 35,000 (7 to 10)
Flame Detection	Flame rod or UV Scanner
Flame Length, inches (mm)	20 to 50 (500 to 1250)
Pipe Threads	BSP or NPT
Fuels <i>For any other mixed gas, contact Eclipse, Inc.</i>	Natural Gas, Propane or Butane
Maximum Air Flow, m <sup>3</sup> /h	7200
Blower Motor Input, HP (kW)	Low Pressure*: 7.38 (5.5) High Pressure**: 7.38 (5.5)
Minimum Blower Air Pressure, "w.c. (mbar)	Low Pressure*: 3.6 (9) High Pressure**: 3.6 (9)
Weight including Blower, lbs (kg)	Low Pressure*: 948 (430) High Pressure**: 948 (430)
Weight without Blower, lbs (kg)	782.6 (355)
Approvals	 AИ30

\* Low Pressure= -2.4 "w.c. (-6 mbar) to 0.4 "w.c. (1 mbar).

\*\* High Pressure= 0.4 "w.c. (1 mbar) to 1.6 "w.c. (4 mbar).

- All information is based on laboratory testing in neutral (0.0"w.c./mbar) pressure chamber. Different chamber size and conditions may affect the data.
- All inputs based upon gross calorific values.
- Eclipse reserves the right to change the construction and/or configuration of our products at any time without being obliged to adjust earlier supplies accordingly.

# Specifications Graphs

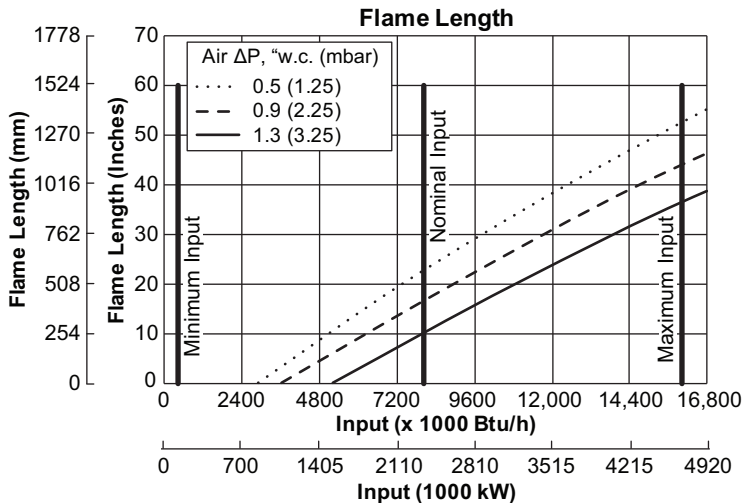
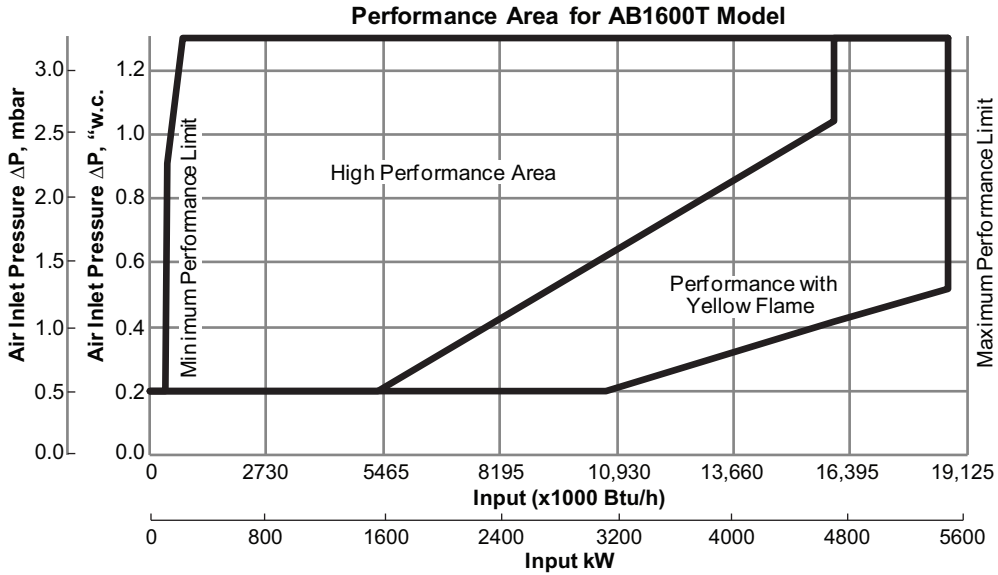
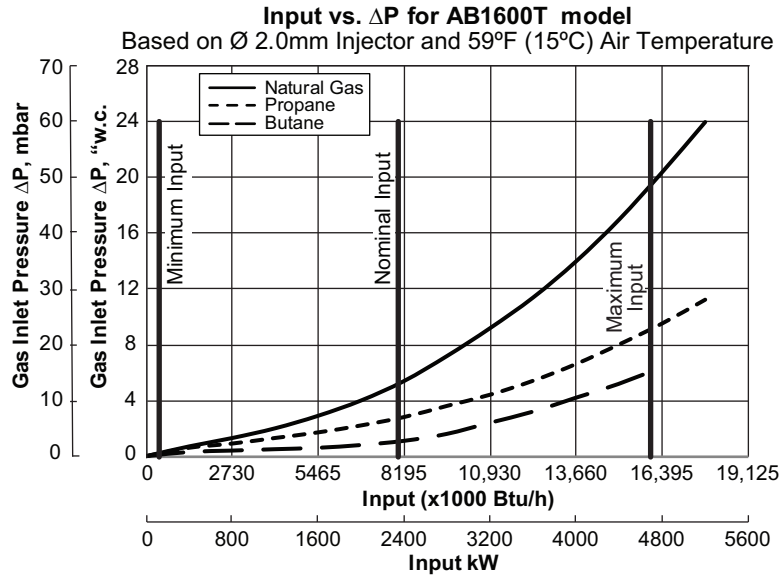

NOTE: Flame length may vary slightly from these values depending on actual fuel, air handling system, duct configurations and profile plates uses.

Air  $\Delta P$  = Air "Burner + Internal Diffuser" pressure drop.

## Emissions Data

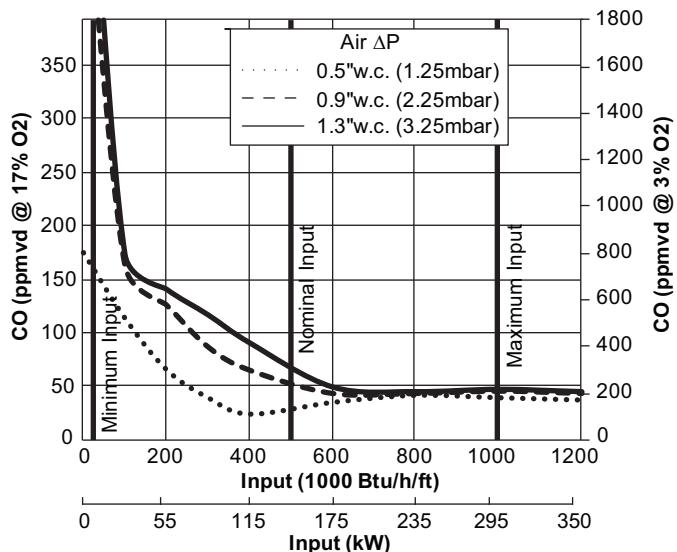
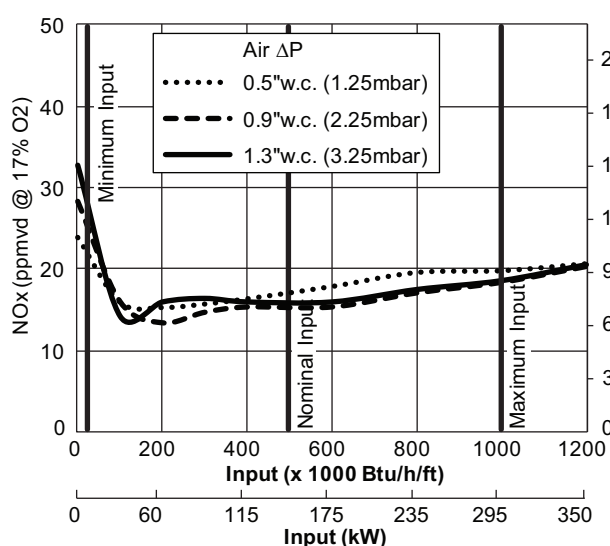

### NO<sub>x</sub> and CO emission data is given for:

- Ambient combustion air ~70°F (21°C)
- Minimal process air velocity
- Neutral chamber pressure
- Natural gas

### Emissions are influenced by:

- Chamber conditions
- Fuel type
- Firing rate

CO emissions are largely influenced by chamber conditions. Contact your local Eclipse representative for an estimate of CO emissions on your application.

## Process Flow Considerations

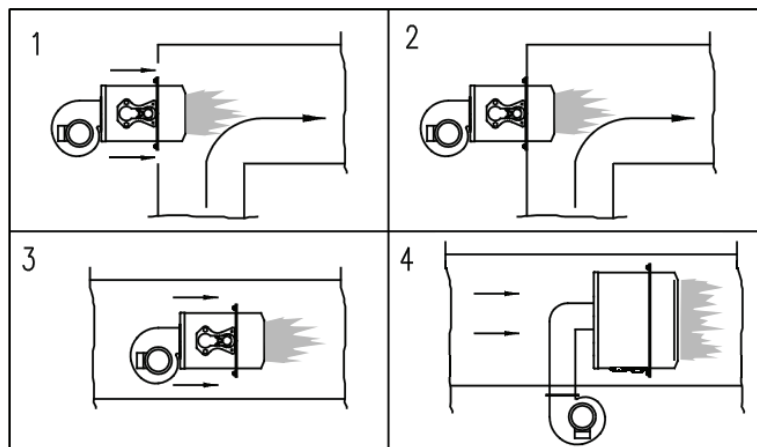

- 1 - External mounting, with air intake slot
- 2 - External mounting
- 3 - Internal mounting, fresh process air used
- 4 - Internal mounting, external air used

Contact Eclipse for other air conditions

### Parallel Process Flow

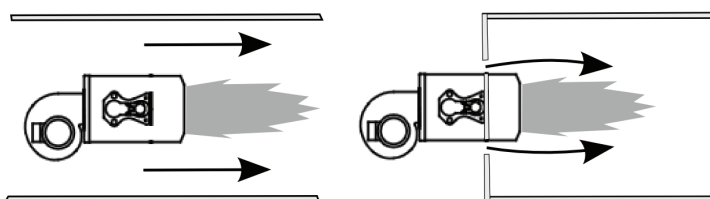

Minimum Velocity: 500 fpm (2.5 m/s)  
 Maximum Velocity: 6000 fpm (31 m/s)  
 Optimum Velocity: 1000 to 4000 fpm (5 to 20 m/s)

### Perpendicular Process Flow

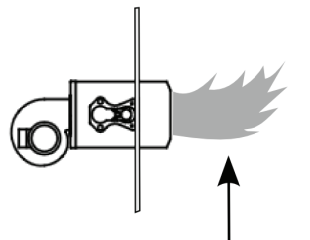

Minimum Velocity: 500 fpm (2.5 m/s)  
 Maximum Velocity: 1200 fpm (6 m/s)

## Dimensions in mm (inches)

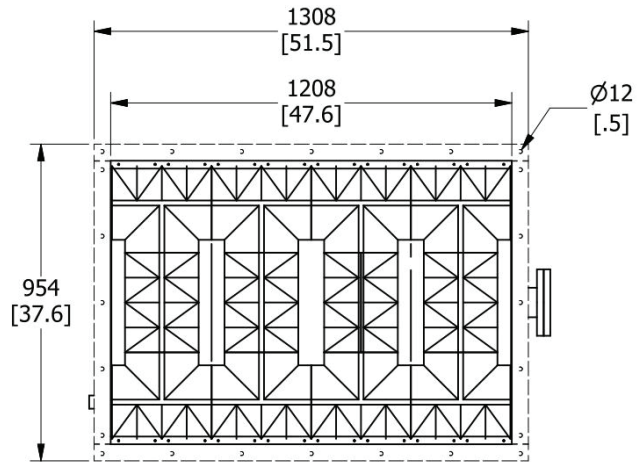
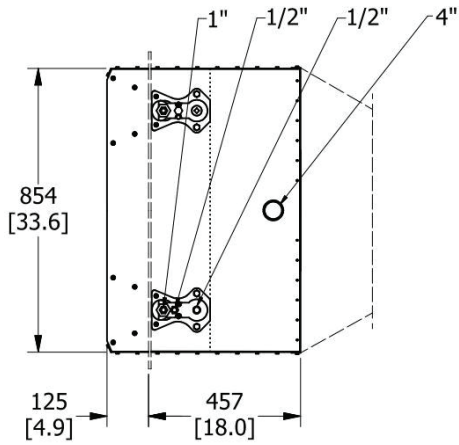

## Wall Mounting Flanges (Customer Supplied)

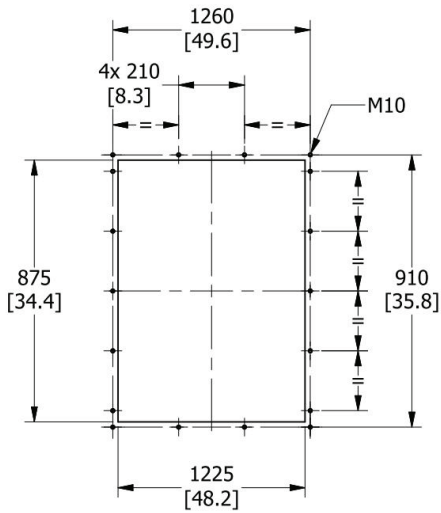

## Connections and Components

### Built-in Pilot Gas

