

Self-recuperative burner ECOMAX for gas

TECHNICAL INFORMATION

- For direct and radiant tube heating
- Economical, energy-saving operation by virtue of internal air preheating up to 650°C
- Uniform distribution of temperature by means of a high burner impulse
- 7 sizes from 25 to 500 kW
- Highly efficient with a ceramic burred tube recuperator or a cast steel ribbed tube recuperator.



Table of contents

Table of contents	2
1 Application	4
1.1 Direct heating	4
1.2 Radiant tube heating	4
1.3 Application examples	5
1.4 ECOMAX for direct heating systems	5
1.4.1 Flow rate control	6
1.4.2 Air/gas ratio control	7
1.4.3 Without pneumatic ratio control system	7
1.5 ECOMAX for radiant tube heating	8
1.5.1 No pneumatic ratio control system	9
1.5.2 Air/gas ratio control	9
2 Certification	10
2.1 Eurasian Customs Union	10
3 Mechanical construction	11
3.1 Burner body	11
3.2 Recuperator	11
3.3 Air guide tube	13
3.4 Gas insert	14
3.5 List of versions	15
4 Function	16
5 Selection	18
5.1 ProFi	18
5.2 Burner type	18
5.3 Burner size	18
5.4 Burner length	19
5.5 Burner head	20
5.6 Type of heating	20
5.7 Connection for additional furnace cooling	20
5.8 Electrode made of Kanthal APM	21
5.9 Selection table	22
5.9.1 ECOMAX..C	22

5.9.2 ECOMAX..M.	23
5.9.3 ECOMAX..P	24
5.9.4 ECOMAX..F	25
5.9.5 Type code	26
5.10 Selection table for flue gas eductor EJEK	27
5.10.1 Type code	28
5.11 Selection table for flue gas connector FLUP	29
5.11.1 Type code	30
6 Direct heating project planning information	31
6.1 Heat design	31
6.2 Flue gas guide tube FGT set	32
6.3 Flue gas eductor EJEK	33
6.4 Flue gas system on the furnace	34
6.5 Installation	35
6.5.1 Installation position	35
6.5.2 Tangential or angled burner installation	35
6.5.3 Clearances	36
6.5.4 Furnace chamber temperature measurement	36
6.5.5 Heat guard	37
6.6 Flame control	37
6.7 Burner control units and ignition transformers	38
6.7.1 Configurations for burner control unit	39
6.8 Gas connection	40
6.8.1 Component selection	40
6.8.2 Gas pressure	40
6.8.3 Operation with LPG	41
6.9 Air connection	42
6.9.1 Component selection	42
6.9.2 Air pressure	43
6.10 Air flow monitoring	43
6.11 Purge air and cooling air	44
6.12 Condition on delivery	45
6.13 Cooling mode with ECOMAX	45
6.14 Emissions	46

6.15 Build up of noise	46
6.16 Process constraint	46
6.17 Resistance of SiSiC	47

7 Radiant tube heating project planning information 48

7.1 Heat design	48
7.2 Radiant tubes	49
7.3 Flue gas channelling	50
7.4 Flue gas system on the furnace	51
7.5 Installation	52
7.5.1 Heat guard	52
7.6 Flame control	53
7.7 Burner control units and ignition transformers	53
7.7.1 Configurations for burner control unit	54
7.8 Gas connection	55
7.8.1 Component selection	55
7.8.2 Gas pressure	55
7.8.3 Operation with LPG	55
7.9 Air connection	56
7.9.1 Component selection	56
7.9.2 Air pressure	57
7.10 Air flow monitoring	57
7.11 Purge air and cooling air	58
7.12 Condition on delivery	59
7.13 Increased furnace cooling with ECOMAX..K.	59
7.14 Emissions	60
7.15 Build up of noise	60

8 Accessories 61

8.1 Air connection set	61
8.2 Air flow detector set	61
8.3 VAH connection set	61
8.4 UV adapter set	61
8.5 Purge air/cooling air nozzles	62
8.6 Flue gas guide tube FGT set..D	63

8.7 Flue gas eductor EJEK	64
8.8 Flue gas connector FLUP	64
8.9 Ceramic radiant tube SER-C.	65
8.10 Segmented flame tube SICAFLEX®	65
8.11 Cruciform spacer	66
8.12 Flue gas guide tube FGT set	67
8.13 Pipework	67
8.13.1 Direct heating	68
8.13.2 Radiant tube heating	69

9 Technical data 70

9.1 Dimensions	71
9.1.1 ECOMAX..C direct heating	71
9.1.2 ECOMAX..M direct heating.	72
9.1.3 ECOMAX..F direct heating	73
9.1.4 ECOMAX..C radiant tube heating	74
9.1.5 ECOMAX..M radiant tube heating.	75
9.1.6 ECOMAX..F radiant tube heating	76

10 Maintenance cycles 77

For more information 78

1 Application

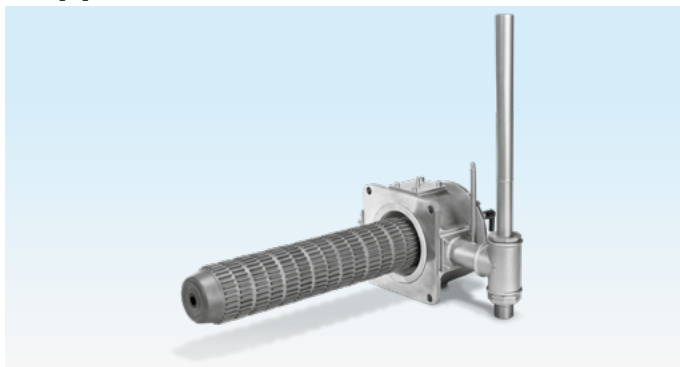

ECOMAX..M

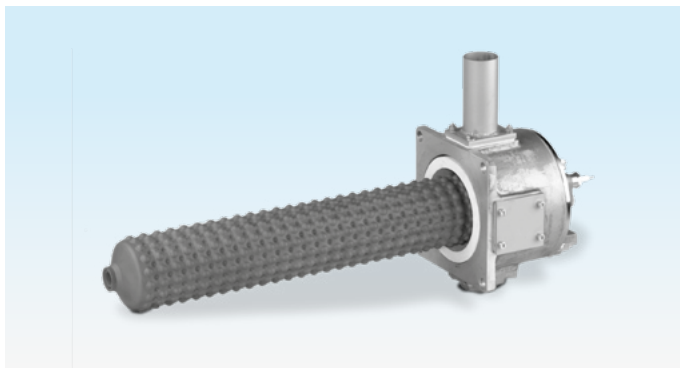

ECOMAX..C

The self-recuperative burners ECOMAX are used for heating furnace systems in ON/OFF intermittent mode. The hot flue gases are fed through the ceramic or metallic heat exchanger integrated in the burner, heating the additional supply of cold combustion air flowing in the opposite direction.

The maximum achievable air preheat temperature is approx. 650°C, depending on the application.

1.1 Direct heating

In conjunction with an eductor EJEK to extract the flue gases, the burner ECOMAX is used to save energy in a direct heating system without the need for long hot air lines which require insulation. Applications include heat treatment furnaces in the steel and iron industry and in the non-ferrous metal industry.

1.2 Radiant tube heating

Self-recuperative burners ECOMAX are used in combination with metallic or ceramic radiant tubes and segmented ceramic flame tubes SICAFLEX for indirect heating. Radiant tube heating systems are used if the combustion gases must be separated from the product, for example for heat treatment furnaces with an inert gas atmosphere in the steel industry or for the heat treatment of aluminium.

1.3 Application examples

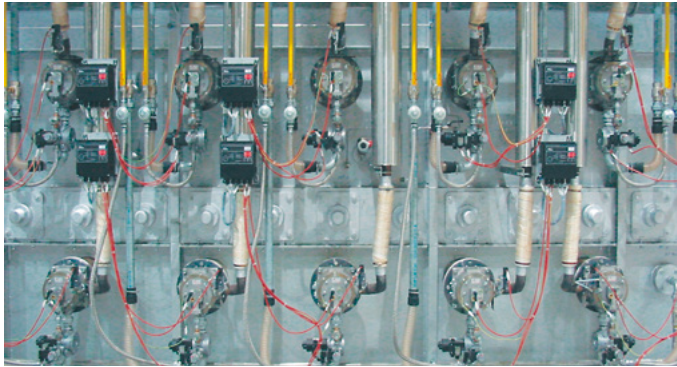

Roller hearth furnace



Bogie hearth furnace



Tailored blank furnace

1.4 ECOMAX for direct heating systems

For direct heating, the burner ECOMAX is combined with a flue gas guide tube FGT set..D to guide the flue gases in the furnace lining and a flue gas eductor EJEK.

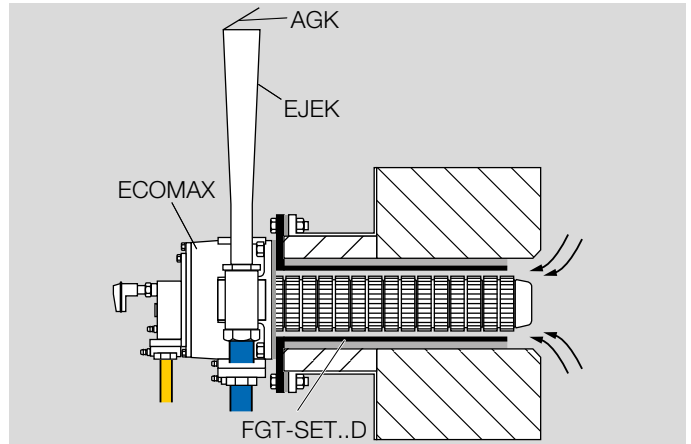

1 Application

The eductor EJEK generates a negative pressure by forcing air through a centrally positioned nozzle and thus draws the flue gases out of the furnace chamber through the burner's heat exchanger. The motive air flow is adjusted on the basis of the negative pressure measured on the pressure tap between the burner and the motive air nozzle. A flue gas valve AGK, which closes due to its own weight, at the eductor minimizes the backflow of hot flue gas from the furnace into the burner or infiltrated air being sucked into the furnace when the burner is switched off.

1.4.1 Flow rate control

A system structure with flow rate control is recommended for a direct heating system. The pressure loss in the recuperator depends on the furnace temperature. As the furnace temperature increases (at constant air supply pressure), the air flow rate drops. This change in the air flow rate is measured by the orifice and the VAH changes the gas volume accordingly so that the air index (λ) on the burner is not dependent on the furnace temperature.

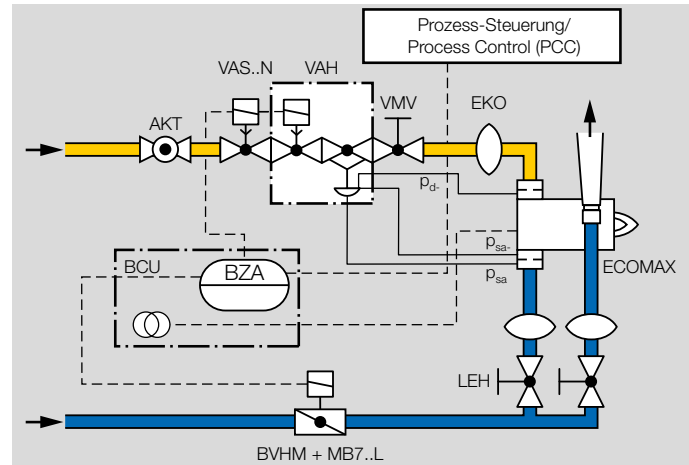

The ECOMAX has an integral air orifice. This can be used to record the air flow rate which can then be used as a reference variable for the VAH. A separate upstream air orifice is therefore no longer required. The impulse line p_{d-} for gas is connected to the burner downstream of the integrated orifice to ensure that a minimal gas pressure is required.

1.4.2 Air/gas ratio control

A system design without a flow rate control does not compensate for any temperature-dependent pressure losses in the burner. The air index λ is reduced as the furnace temperature increases (increasing air preheating). Therefore, an increased λ is to be set when the furnace is cold so that there is adequate excess air even at maximum furnace temperature. A hot furnace at a temperature of 1100°C with $\lambda = 1.1$ (approx. 2% O₂), for example, requires the burner being set to 4% O₂ when the furnace is cold.

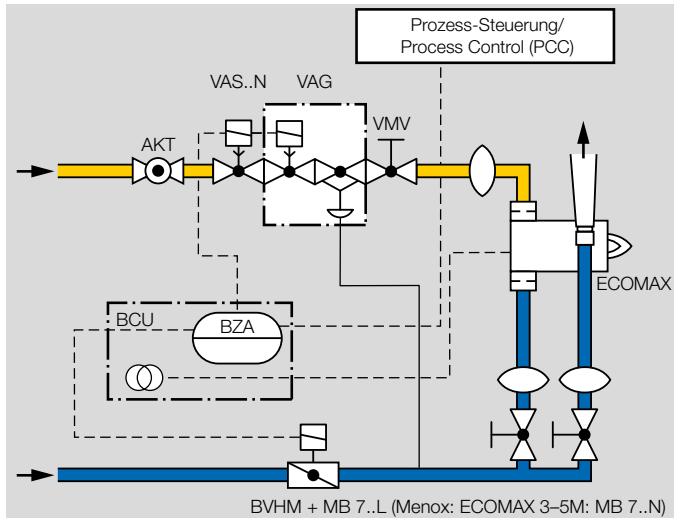

1.4.3 Without pneumatic ratio control system

Slow opening gas valves and quick opening air control valves are to be used to ensure a safe burner start for applications without a pneumatic ratio control system.

If no pneumatic ratio control system is used, the gas and air pressure in the supply lines must be controlled and moni-

tored. Fluctuations in the supply pressure affect the burner capacity and the air index (λ).

An air flow monitor is recommended to act as a low air pressure protection device (pursuant to EN 746-2 and ISO 13577-2) in the system design without a pneumatic ratio control system. The ECOMAX has an integral air orifice which can be used for this purpose. The air flow monitor can also be used to monitor the pre-purge.

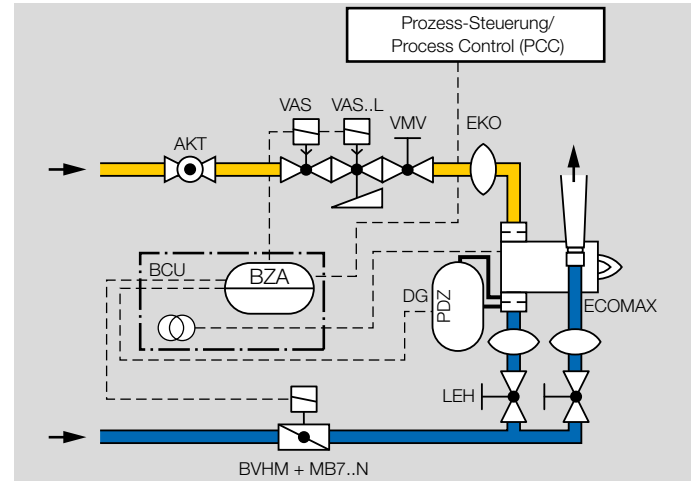

1.5 ECOMAX for radiant tube heating

Various radiant tubes are used for radiant tube heating.

Single ended radiant tube

Indirect heating systems with the burner ECOMAX may use a metallic radiant tube SER-M or a ceramic radiant tube SER-C. Within the radiant tube, the flue gases are guided in an internal flame tube made of SICAFLEX elements. The flue gases are discharged through a flue gas connector FLUP.

The high outlet velocity of the flame recirculates the flue gases to achieve:

- a reduction in NO_x emissions,
- a uniform radiant tube temperature.

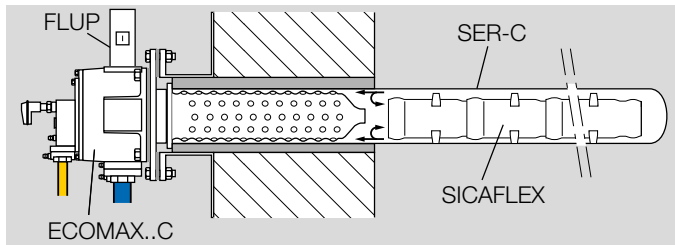
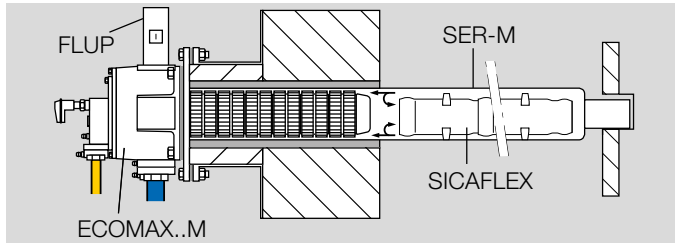

P and twin P radiant tubes

P or twin P radiant tubes are used in some processes, for example in heat treatment systems for steel strip, as an

alternative to U or W radiant tubes. The benefit of this is the larger radiant tube surface area to dissipate heat into the process compared to the single ended radiant tube. The ECOMAX..P burner version with a special recuperator head is available for these radiant tubes.

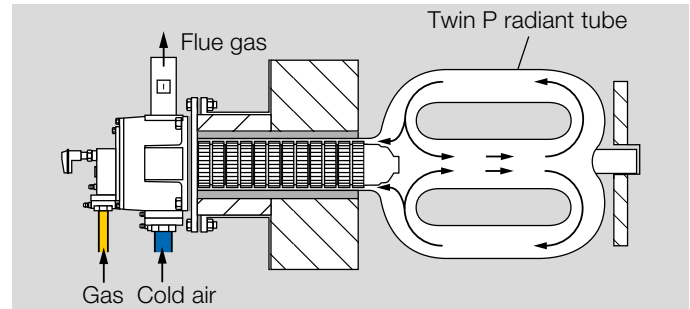
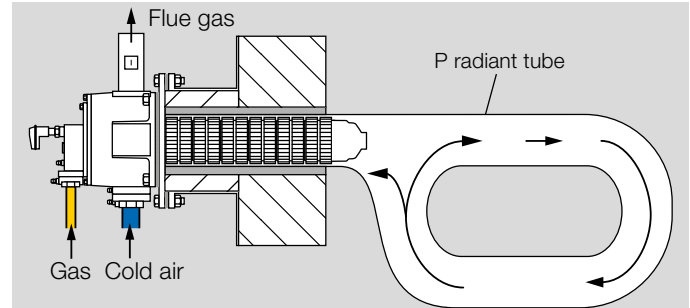

1 Application

1.5.1 No pneumatic ratio control system

Slow opening gas valves and quick opening air control valves are to be used to ensure a safe burner start for radiant tube heating.

If no pneumatic ratio control system is used, the gas and air pressure in the supply lines must be controlled and monitored. Fluctuations in the supply pressure affect the burner capacity and the air index (λ).

A system design with an air flow monitor is recommended to monitor the pre-purge and to act as a low air protection device (pursuant to EN 746-2 and ISO 13577-2). The ECOMAX has an integral air orifice which can be used for this purpose.

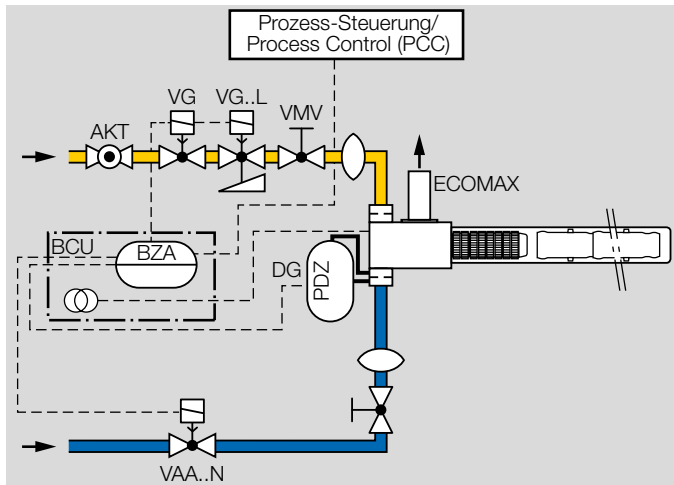

1.5.2 Air/gas ratio control

The pneumatic ratio control system ensures that changes to the pressure in the air supply are compensated by corresponding regulation of the gas pressure at the burner.

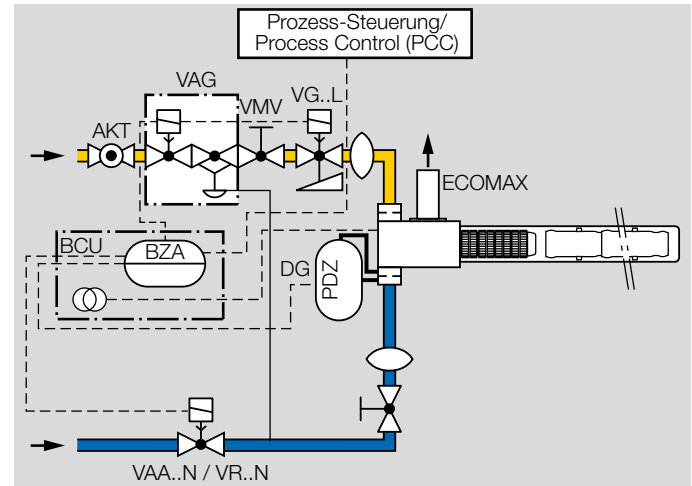

A system design with an air flow monitor is recommended to monitor the pre-purge (pursuant to EN 746-2 and ISO 13577-2) even with a pneumatic ratio control system.

2 Certification

Certificates – see www.docuthek.com

Machinery Directive

The product ECOMAX is a partly completed machine pursuant to Article 2g of Directive 2006/42/EC and complies with the essential health and safety requirements set out in Annex I, as specified in the Declaration of Incorporation.

2.1 Eurasian Customs Union

The image shows the Eurasian Conformity (EAC) mark logo, which consists of the letters 'EAC' in a bold, sans-serif font, centered within a light gray rectangular background.

The products ECOMAX meet the technical specifications of the Eurasian Customs Union.

3 Mechanical construction

The burner ECOMAX is composed of four modules: burner body, recuperator, air guide tube and gas insert. The modular design facilitates adapting the burners to the respective application or integrating them into an existing furnace system. Maintenance and repair times are reduced, and existing furnace installations can easily be converted.

3.1 Burner body

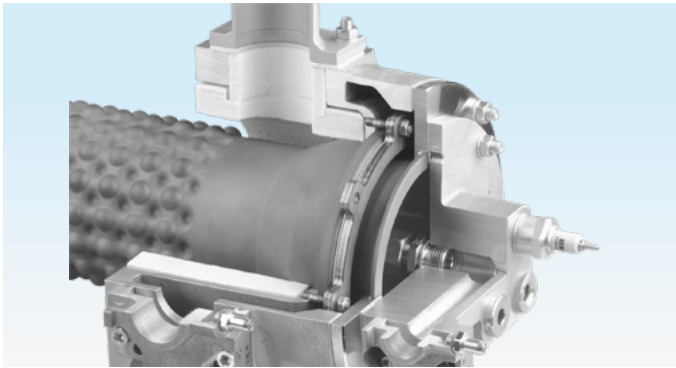

The burner body is made of cast aluminium, which means it has a low weight. The housing has a double-wall design. The combustion air is fed into the burner via the outer annular void. This cools the burner body and reduces emissions. On the flue gas side, there is a shaped part made of vacuum-formed ceramic fibres (RCF) inserted in the housing to act as internal insulation.

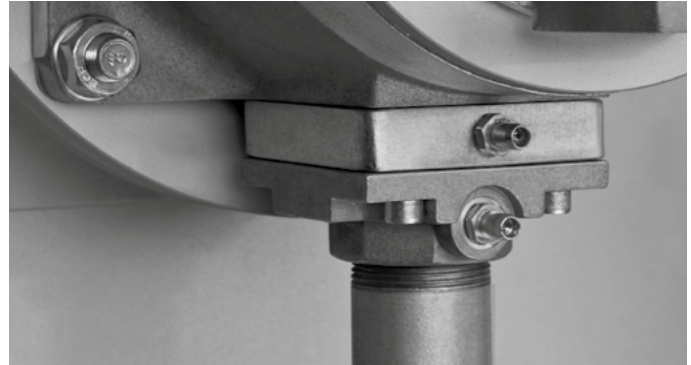

As from construction stage B, the ECOMAX has two pressure test points as standard on the air connection to allow the differential pressure to be measured using the orifice for adjusting the burner.

3.2 Recuperator

The burner ECOMAX is available in three versions:

- ECOMAX..C with ceramic burlled tube recuperator
- ECOMAX..M and ECOMAX..P with cast steel ribbed tube recuperator
- ECOMAX..F with metallic flat tube recuperator

Ceramic burled tube recuperator

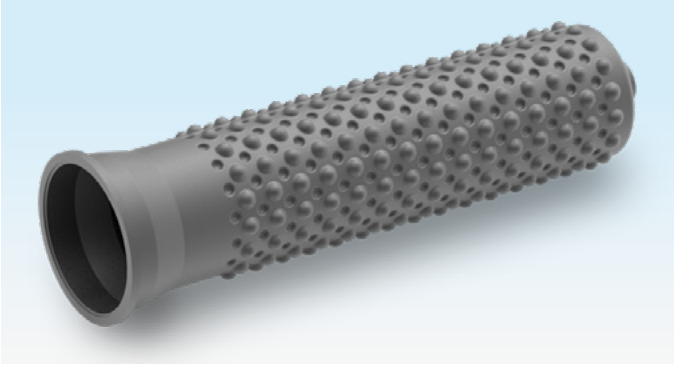

The surface of the ceramic recuperator, which is made of SiSiC for very high thermal stress, is burled in order to achieve high efficiency levels.

Cast steel ribbed tube recuperator

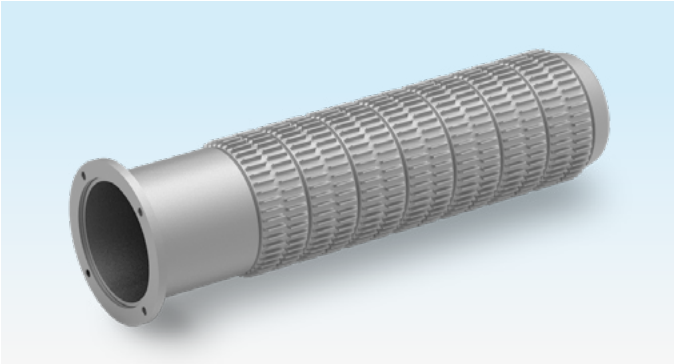

The ribs on the cast steel ribbed tube recuperator create a large surface area, allowing it to achieve high efficiency levels even at low temperatures.

The ECOMAX..P version with a special recuperator head is designed for use in P radiant tubes. The geometry tailored

to this application improves the flue gas recirculation and therefore the temperature uniformity of the radiant tube.

Flat tube recuperator

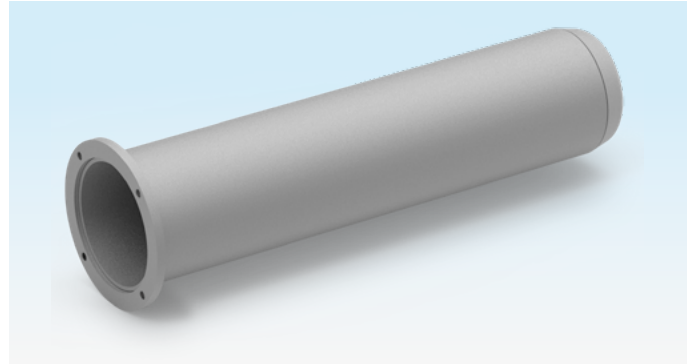

The flat tube recuperator has a smooth surface. It is a cost-effective alternative with a lower efficiency level.

3.3 Air guide tube

ECOMAX..C

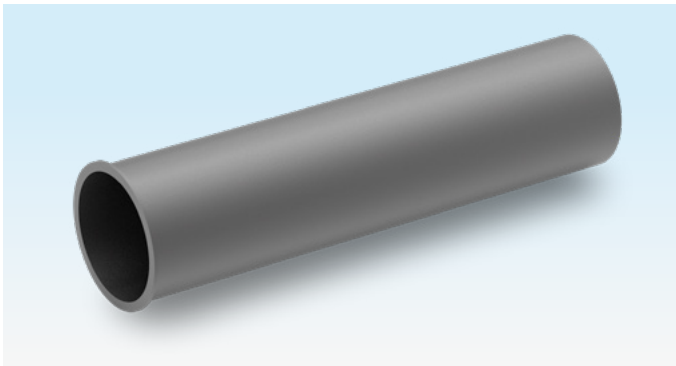
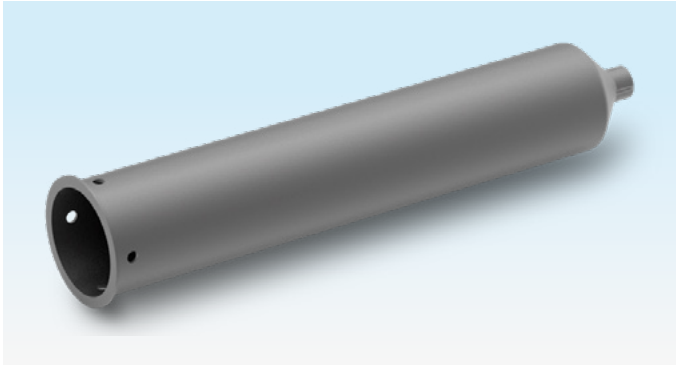

Burners ECOMAX..C are equipped with a ceramic air guide tube that for sizes 0 to 3 also serves as the combustion chamber.

ECOMAX..M, ECOMAX..F and ECOMAX..P

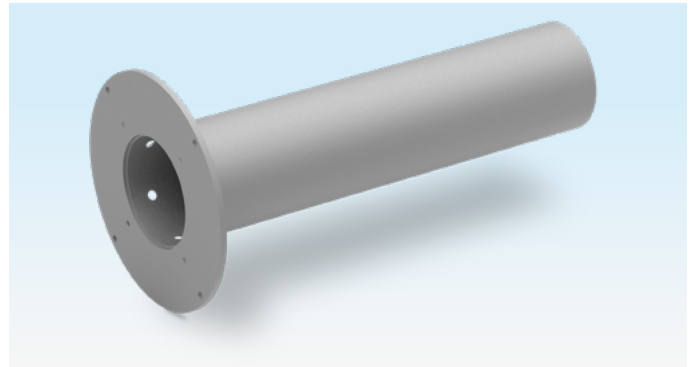

Air guide tube for ECOMAX..M and ECOMAX..F

Burners ECOMAX..M and ECOMAX..F have an air guide tube made of heat-resistant steel.

3.4 Gas insert

The gas insert consists of the gas connection flange, the gas lance with burner head and the spark electrode (also serves as monitoring electrode). An integrated measuring orifice in the gas insert makes it possible to carry out a simple measurement of the gas flow rate. The orifice is designed to suit the gas type (see 5.4.2).

An uninhibited flow is required to ensure accurate measurements of the pressure differential on the integrated orifice. The burners ECOMAX are therefore supplied as standard with a special pipe nipple to act as the inlet section at the gas connection.

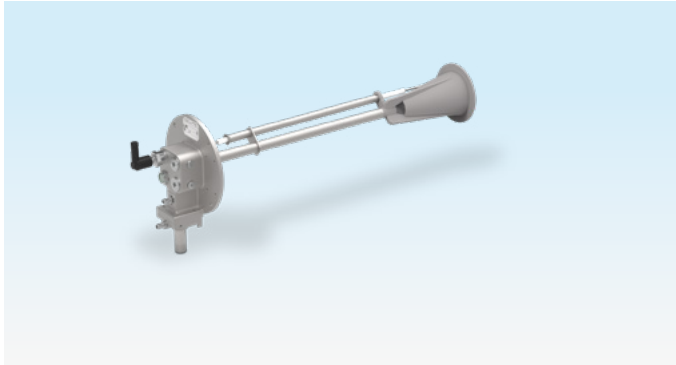

Gas insert without combustion chamber for ECOMAX..C (sizes 0–3)

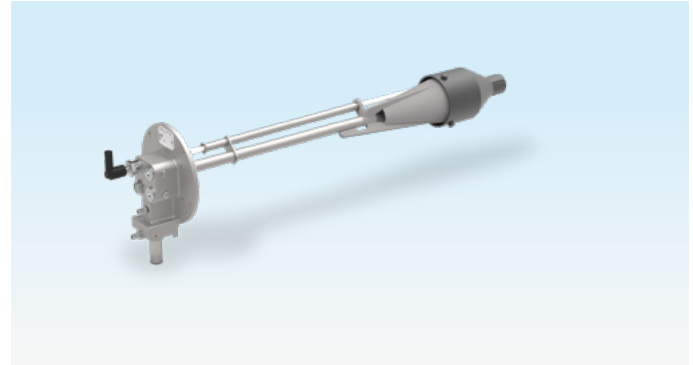

Gas insert with combustion chamber for ECOMAX..M (sizes 1–3)

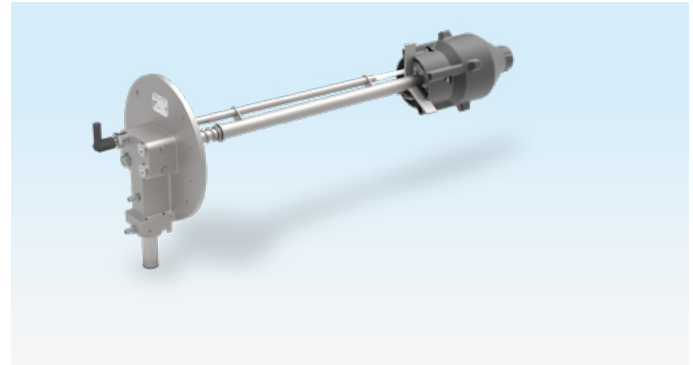

Gas insert with combustion chamber for ECOMAX (sizes 4–5)

3.5 List of versions

Burner	Size	Gas insert	Air guide tube
ECOMAX..C	0-3	With mixing funnel	Ceramic, with integrated combustion chamber
ECOMAX..C	4-5	With swirl plate and ceramic combustion chamber	Ceramic
ECOMAX..M ECOMAX..P ECOMAX..F	1-3	With mixing funnel and ceramic combustion chamber	Metallic
ECOMAX..M ECOMAX..P ECOMAX..F	4-6	With swirl plate and ceramic combustion chamber	Metallic

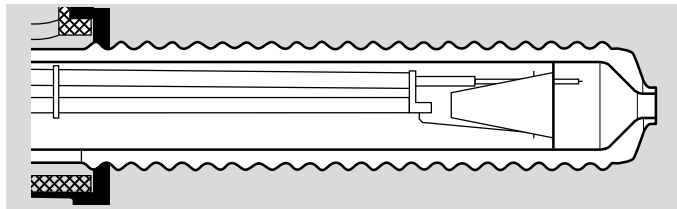

ECOMAX..C 0-3

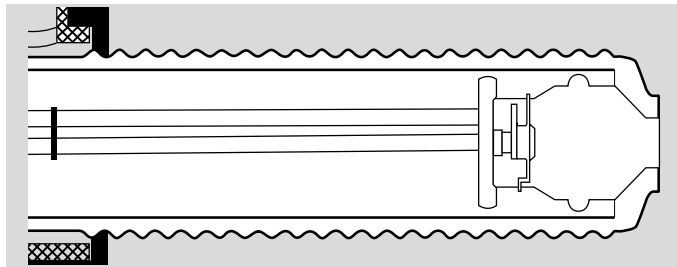

ECOMAX..C 4-5

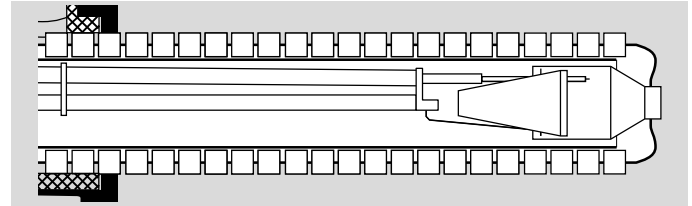

ECOMAX..M 1-3

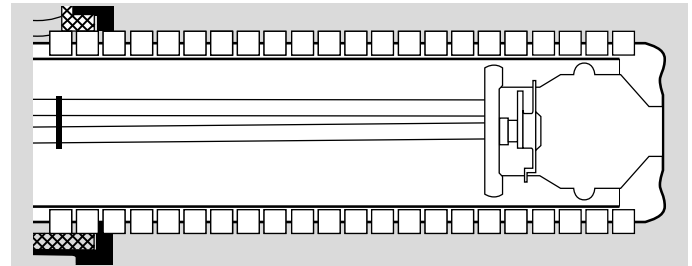

ECOMAX..M 4-5

4 Function

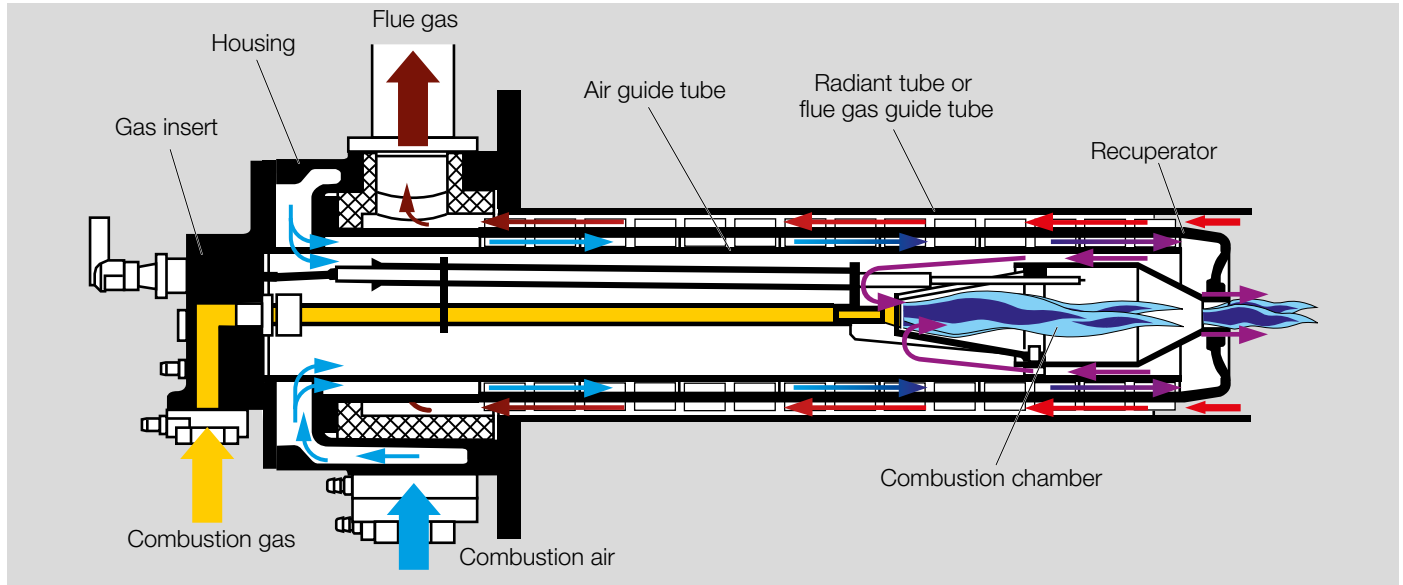

The self-recuperative burner ECOMAX uses the heat from the flue gases to preheat the combustion air. The heat exchanger (recuperator) required for this is part of the burner. After entering the gap between the air guide tube and the recuperator, the combustion air flows towards the burner nozzle (blue arrows). Some of this air is fed into the inside of the burner, where it is combusted in the first combustion stage.

The rest of the combustion air flows at high speed through the gap between the combustion chamber and the recuperator head where it is combusted in the second combustion stage (violet arrows). This process means that fewer pollutant emissions are produced. The hot flue gases,

flowing in the opposite direction, exit the furnace chamber on the outside of the recuperator (red arrows). Heat is exchanged between the hot flue gases and the cold combustion air through the recuperator wall.

Influence of furnace temperature

The pressure losses from the combustion air and flue gas in the recuperator rise with the furnace temperature.

As the furnace temperature increases (at constant air supply pressure), the air mass flow (= standard air flow rate) drops while the gas flow rate remains almost unaffected. A system design with air/gas ratio control or without a pneumatic ratio control system does not compensate for any temperature-dependent pressure losses in the burner. The

air index λ is reduced as the furnace temperature increases. A pneumatic ratio control system can be used to avoid this, see page 6 (1.4.1 Flow rate control).

For direct heating with flue gas eductor EJEK, as the furnace temperature increases, the volume of flue gas drawn in through the burner from the furnace chamber is reduced. If the gas flue extraction rate is 80–90% at maximum furnace temperature, a negative furnace pressure will generally be avoided even at a furnace temperature reduced by 400–500°C.

Ignition and flame control

The burner is directly ignited.

The ignition and flame control takes place with a combined spark electrode/flame rod (single-electrode operation).

Flame control with a UV sensor is only required if the furnace temperatures exceed 1150°C (2102°F) for direct heating or 1050°C (1922°F) for radiant tube heating.

5 Selection

5.1 ProFi

A web app selecting the correct product is available at www.adlatus.org.

5.2 Burner type

Selection is dependent on the type of heating and the furnace temperature. Selection details for direct heating, see page 31 (6.1 Heat design), or for radiant tube heating, see page 48 (7.1 Heat design).

Burner	Max. flue gas temperature at recuperator inlet	
	[°C]	[°F]
ECOMAX..C	1250	2282
ECOMAX..M, ECOMAX..P	1150	2102
ECOMAX..F	1050	1922

5.3 Burner size

Size	Capacity		Recuperator			
	kW ¹⁾	kBTU/h ²⁾	C	M	P	F
ECOMAX 0	25	95	•	–	–	–
ECOMAX 1	36	136	•	•	–	•
ECOMAX 2	60	227	•	•	•	•
ECOMAX 3	100	378	•	•	•	•
ECOMAX 4	180	681	•	•	•	•
ECOMAX 5	250	945	•	•	–	•

• = available

¹⁾ Capacities in kW refer to the lower heating value LHV.

²⁾ Capacities in BTU/h refer to the higher heating value HHV (gross calorific value).



Capacity values refer to operation with natural gas. For operation with coke oven gas, the output is approx. 80%, for operation with LCV gas, approx. 65%.

If the burners are used at geodetic altitudes of over 500 m above MSL, the possible capacity will be lower as a result of the reduced density of gas and air. Guide value 5% per 1000 m above MSL, details available on request.

ECOMAX 6 M recuperator for 500 kW (1890 kBTU/h) available on request.

5.4 Burner length

The recuperator length **G** and the furnace geometry should be coordinated so that the burner is flush with the inside edge of the furnace lining (**S1** = 0 ± 20 mm).

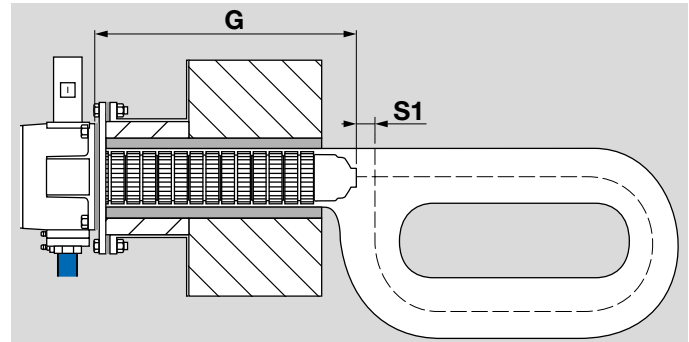
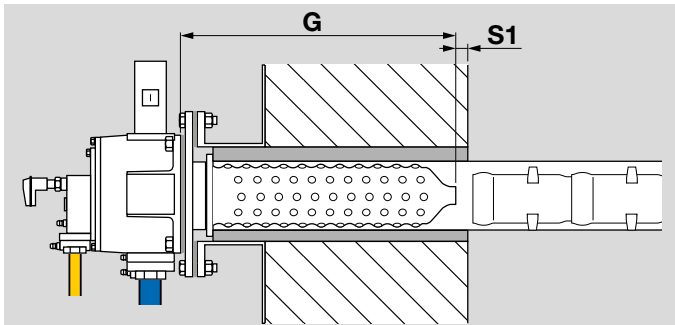
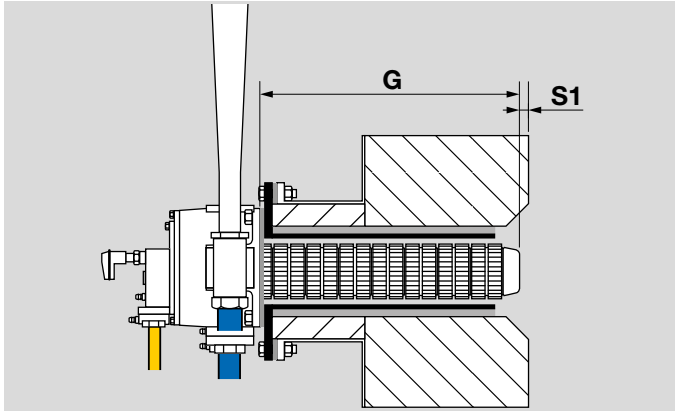

For P radiant tubes, the recuperator head should be positioned on a central line in the radiant tube (**S1** = 0 ± 20 mm).

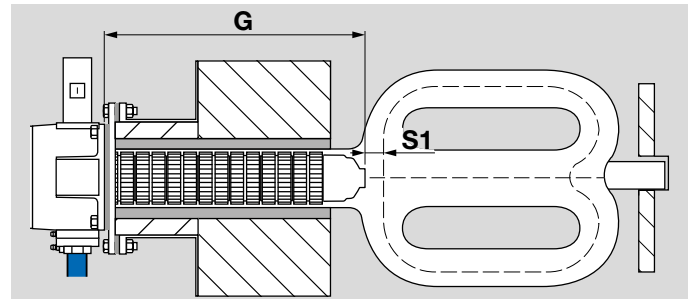

5.5 Burner head

Use

The burner ECOMAX can be supplied with two different burner heads. The standard is a staged combustion head. On some burner versions, a menox design is also possible which, for direct heating furnace chamber temperatures of over 850°C, allows a switchover to low NO_x operation menox® with flameless combustion.

Use	Burner head code letter
Standard Flame mode	S
menox low NO _x mode ¹⁾	M

¹⁾ menox® low NO_x mode on request.

Gas type

	Code letter	Heating value range		Density ρ	
		kWh/m ³ (st) ²⁾	BTU/scf ³⁾	kg/m ³ (st)	lb/scf
Natural gas L and H quality	B	8–12	810–1215	0.7–0.9	0.041–0.053
Propane, propane/butane, butane	G	25–35	2560–3474	2.0–2.7	0.118–0.159
Coke oven gas, town gas	D	4–5	421–503	0.4–0.6	0.024–0.035
Low calorific value gas	L	1.7–3 ¹⁾	161–290	0.9–1.15	0.053–0.068

¹⁾ Heating value range < 1.7 on request.

²⁾ Heating value ranges in kWh/m³ refer to the lower heating value LHV.

³⁾ Heating value ranges in BTU/scf refer to the higher heating value HHV (gross calorific value).

5.6 Type of heating

The ECOMAX is supplied with an integrated orifice on the gas and air connection.

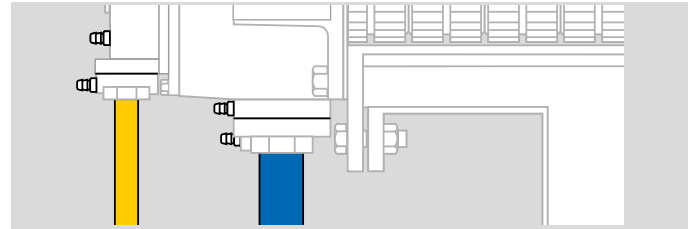

The gas orifices depend on the gas type, the air orifices depend on the control type and system structure.

Type of heating	Code letter	Explanation
Direct heating with eductor	/D-	Air orifice adjusted to 65 mbar air pressure (= EJEK motive air pressure)
Radiant tube heating without eductor	/R-	Air orifice adjusted to 50–60 mbar air pressure

5.7 Connection for additional furnace cooling

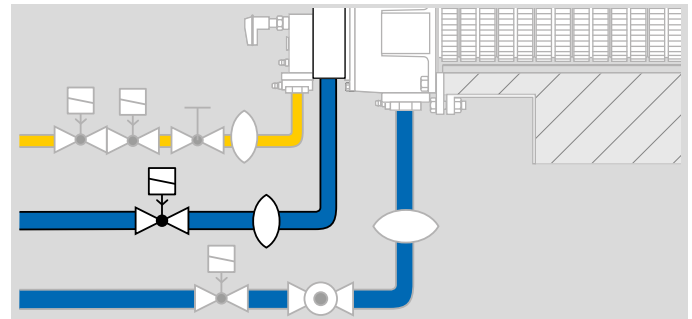

The air volume supplied to the burner in cooling mode can be increased using an optional intermediate flange with an additional cooling air connection on the burner ECOMAX.

The air supplied through the additional air connection flows in the centre of the burner inside the air guide tube. The volume is around twice the normal combustion air.

5.8 Electrode made of Kanthal APM

As an option, the burners ECOMAX..M and ECOMAX..P can be supplied with a bend-resistant electrode made of Kanthal APM. Recommended for direct heating from a temperature of 1050°C, see page 37 (6.6 Flame control), and radiant tube heating from a temperature of 950°C, see page 53 (7.6 Flame control).

The Kanthal electrode is standard on the ECOMAX..C.

5.9 Selection table

5.9.1 ECOMAX..C

Option	ECOMAX 0C	ECOMAX 1C	ECOMAX 2C	ECOMAX 3C	ECOMAX 4C	ECOMAX 5C
Recuperator length in mm	395, 475, 556, 636	545, 593, 641, 689	545, 613, 681	545, 617, 689	545, 595, 645, 695	545, 595, 645, 695
Use	-S	-S	-S	-S	-S	-S
Gas type ¹⁾	B, D, G	B, D, G	B, D, G, L ²⁾	B, D, G, L ²⁾	B, D, G, L ²⁾	B, D, G, L ²⁾
Type of heating	/D-, /R-	/D, /R-	/D-, /R-	/D-, /R-	/D-, /R-	/D-, /R-
Burner head identifier	(1–99)	(1, 2... 31...99)	(1–99)	(1–99)	(1–99)	(1–99)
Construction stage	A- – E-	A-, B...E-	A- – E-	A- – E-	A- – E-	A- – E-
Special design electrode	A	A	A	A	A	A
Special design cooling air	K	K	K	K	K	K
Special design pipe connection	T	T	T	T	T	T

¹⁾ Other gas types on request

²⁾ On request

ECOMAX..C is supplied as standard with Kanthal electrodes.

Order example

ECOMAX 1C545-SB/R-(31)B-A

5.9.2 ECOMAX..M

Option	ECOMAX 1M	ECOMAX 2M	ECOMAX 3M	ECOMAX 4M	ECOMAX 5M
Recuperator length in mm	545, 595, 645, 695	545, 595, 645, 695	545, 595, 645, 695	545, 595, 645, 695	545, 595, 645, 695
Use	-S	-S	-S, -M	-S, -M	-S, -M
Gas type ¹⁾	B, D, G	B, D, G, L ²⁾	B, D, G, L ²⁾	B, D, G, L ²⁾	B, D, G, L ²⁾
Type of heating	/D-, /R-	/D-, /R-	/D-, /R-	/D-, /R-	/D-, /R-
Burner head identifier	(1-99)	(1, 2... 33...99)	(1-99)	(1-99)	(1-99)
Construction stage	A- - E-	A-, B-...E-	A- - E-	A- - E-	A- - E-
Special design electrode	A	A	A	A	A
Special design cooling air	K	K	K	K	K
Special design pipe connection	T	T	T	T	T

¹⁾ Other gas types on request

²⁾ On request

Order example

ECOMAX 2M545-SB/D-(33)B-

5.9.3 ECOMAX..P

Option	ECOMAX 2P	ECOMAX 3P	ECOMAX 4P
Recuperator length in mm	645, 695	645, 695	645, 695
Use	-S	-S	-S
Gas type ¹⁾	B, D, G, L ²⁾	B, D, G, L ²⁾	B, D, G, L ²⁾
Type of heating	/R-	/R-	/R-
Burner head identifier	(1-99)	(1, 2... 34...99)	(1-99)
Construction stage	A- - E-	A-, B...E-	A- - E-
Special design cooling air	K	K	K
Special design pipe connection	T	T	T

¹⁾ Other gas types on request

²⁾ On request

Order example

ECOMAX 3P695-SB/R-(34)B-

5.9.4 ECOMAX..F

Option	ECOMAX 1F	ECOMAX 2F	ECOMAX 3F	ECOMAX 4F	ECOMAX 5F
Recuperator length in mm	545, 595, 645, 695	545, 595, 645, 695	545, 595, 645, 695	545, 595, 645, 695	545, 595, 645, 695
Mode of operation	-S	-S	-S	-S	-S
Gas type ¹⁾	B, D, G	B, D, G, L ²⁾	B, D, G, L ²⁾	B, D, G, L ²⁾	B, D, G, L ²⁾
Type of heating	/D-, /R-	/D, /R-	/D-, /R-	/D-, /R-	/D-, /R-
Burner head identifier	(1-99)	(1, 2... 33...99)	(1-99)	(1-99)	(1-99)
Construction stage	A-E	A, B...E	A-E	A-E	A-E
The following features differ from the standard version:					
Special design cooling air	K	K	K	K	K
NPT connections	T	T	T	T	T

¹⁾ Other gas types on request

²⁾ On request

Order example

ECOMAX 2F545-SB/R-(33)B

5 Selection

5.9.5 Type code

ECOMAX	Self-recuperative burner
0-5	Burner size
C	With ceramic burlud tube recuperator made of SiSiC
M	With cast steel ribbed tube recuperator
F	With metallic flat tube recuperator
P	With cast steel ribbed tube recuperator for P radiant tube
E	Special recuperator version
395-695	Recuperator length [mm]
-S	With staged combustion
-M	For menox low NOx operation
B	Natural gas
D	Coke oven gas
G	LPG
L	LCV gas
/D-	For direct heating with eductor
/R-	For radiant tube heating without eductor
/E-	Burner with customized orifices
/N-	Burner without orifices
/nnn-	Burner construction stage X for nnn kW
/V-	For radiant tube heating with VAH
(1-99)	Burner head identifier
A-, B-, ...	Construction stage
A	Electrode made of Kanthal APM
K	Additional cooling air connection for increased furnace cooling
T	NPT connections
S	With spacer for SICAFLEX

W	Air connection without intermediate flange
Z	Special version

5.10 Selection table for flue gas eductor

EJEK

Option	EJEK 0	EJEK 1	EJEK 2	EJEK 3	EJEK 4	EJEK 5	EJEK 6
Axis spacing in mm ¹⁾	-K269	-K269	-K285	-K292	-K345	-K345	-K530
Installation height in mm	-M625	-M625	-M540	-M620	-M920	-M1165	-M1618
Distance in mm ¹⁾	-T50-500	-T50-500	-T50-500	-T50-500	-T50-500	-T50-500	-T50-500
Burner installation position		-H, -V	-H, -V				
Installation on the burner ²⁾	-3, -9	-3, -9	-3, -9	-3, -9	-3, -9	-3, -9	-3, -9
Eductor angle	-F5-15, -R5-15	-F5-15, -R5-15	-F5-15, -R5-15	-F5-15, -R5-15	-F5-15, -R5-15	-F5-15, -R5-15	-F5-15, -R5-15
With mechanical flue gas valve	-AGK	-AGK	-AGK	-AGK	-AGK	-AGK	-AGK
High temperature version ³⁾	-HT	-HT	-HT	-HT	-HT	-HT	-HT
Construction stage	-A, -B	-A, -B	-A, -B	-A, -B	-A, -B	-A, -B	-A, -B
Standard dimensions	-S	-S	-S	-S	-S	-S	-S

¹⁾ Special dimensions on request

²⁾ Only relevant for special dimensions T

³⁾ HT version for ECOMAX..C

Order example

EJEK 1-K269-M625-H-AGK-A-S

5 Selection

5.10.1 Type code

EJEK	Flue gas eductor
0-6	Size
-K296-530	Axis spacing K in mm
-M620-1165	Installation height M in mm
-T50-500	Distance T in mm
-H	Burner installation position: horizontal
-V	Burner installation position: vertical
-3	Installation on the burner: right
-9	Installation on the burner: left
-F5-15	Eductor angle: x° towards the furnace
-R5-15	Eductor angle: x° away from the furnace
-AGK	With mechanical flue gas valve
-HT	High temperature version
A, B	Construction stage
-S	Standard dimensions

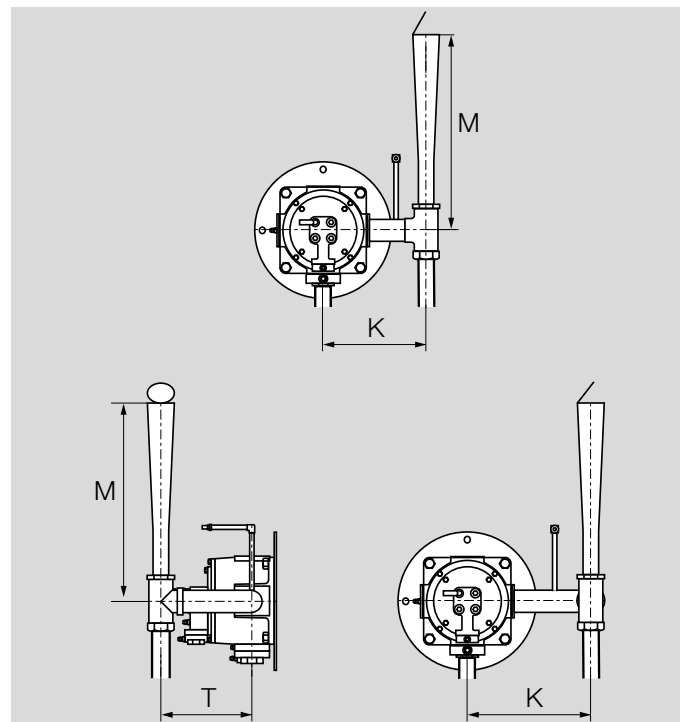

5.11 Selection table for flue gas connector FLUP

Option	FLUP 0	FLUP 1-2	FLUP 3	FLUP 4-5
Nominal diameter	-32	-50	-65	-100
Pipe connection	D, F	D, F	D, F	D, F
Axis spacing in mm	-K100-800	-K100-800	-K100-800	-K100-800
Installation height in mm ¹⁾	-M230	-M231	-M353	-M399
Distance in mm ¹⁾	-T10-900	-T10-900	-T10-900	-T10-900
Burner installation position ²⁾		-H, -V		
Installation on the burner ²⁾	-0, -3, -9	-0, -3, -9	-0, -3, -9	-0, -3, -9
Pressure test point	-C, -A	-C, -A	-C, -A	-C, -A
High temperature version	-HT	-HT	-HT	-HT
Construction stage	-B			
Standard dimensions	-S	-S	-S	-S

¹⁾ Special dimensions on request

²⁾ Only relevant for special dimensions K and/or T

Order example

FLUP 3-65D-M353-C-S

5 Selection

5.11.1 Type code

FLUP	Flue gas connector
0-6	Size
-32-100	Nominal size
D	Pipe connector
F	Flange to ISO 7005
-K296-530	Axis spacing K in mm
-M620-1165	Installation height M in mm
-T50-500	Distance T in mm
-H	Burner installation position: horizontal
-V	Burner installation position: vertical
-0	Installation on the burner: top
-3	Installation on the burner: right
-9	Installation on the burner: left
-C	Measuring port with sealing clip
-A	Threaded pressure tap with cap
-HT	High temperature version
A, B	Construction stage
-S	Standard dimensions

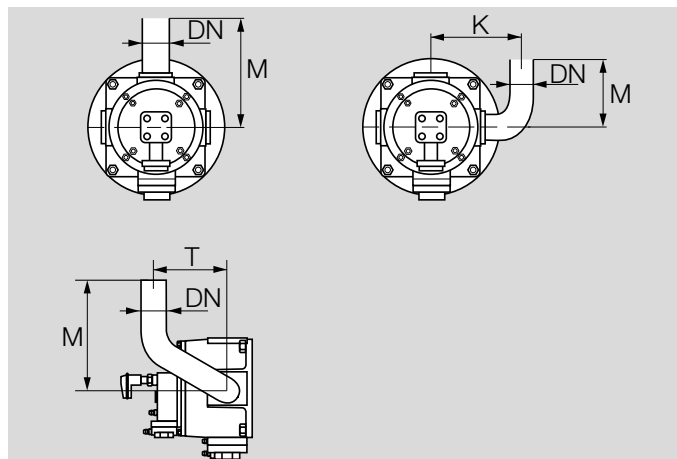

6 Direct heating project planning information

6.1 Heat design

The selection of the burner type depends on the furnace chamber temperature.

Burner	Recommended range of application		Max. flue gas temperature at recuperator inlet	
	[°C]	[°F]	[°C]	[°F]
ECOMAX..C	up to 1250	up to 2282	1250	2282
ECOMAX..M	up to 1100	up to 2012	1150	2102
ECOMAX..F	up to 1000	up to 1832	1050	1922

The burners ECOMAX..M (sizes 1 to 5) and ECOMAX..F can be used for furnace chamber temperatures up to the maximum application temperature if it can be ensured that the burner head will not overheat, for example due to opposite burners or non-representative temperature measurements, see also page 36 (6.5.4 Furnace chamber temperature measurement).

Selection of the burner size is dependent on the net heat output. From this, the required burner capacity is calculated using the firing efficiency value.

$$\frac{\text{Net heat output [kW]}}{\text{Firing efficiency } \eta} = \text{Burner capacity [kW]}$$

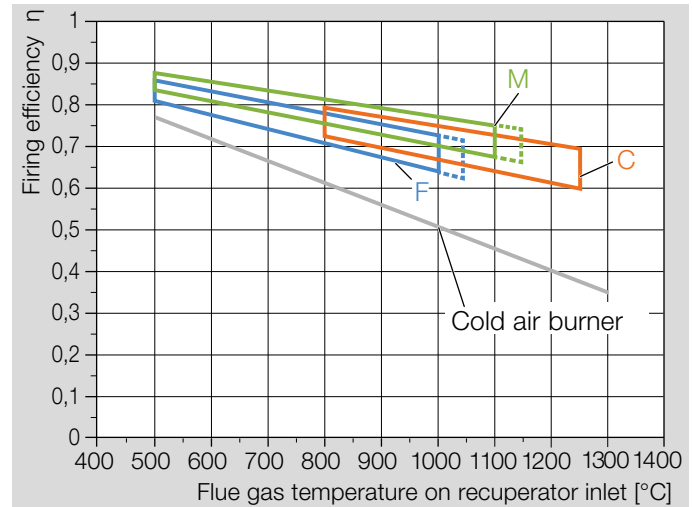

A detailed heat design is available on request.

6.2 Flue gas guide tube FGT set

The flue gases are routed out of the furnace in the flue gas guide tube through the recuperator in the furnace lining. The FGT set must be ordered separately and is not supplied in the burner package, see page 63 (8.6 Flue gas guide tube FGT set..D).

The flange thickness **F1** of the flue gas guide tube including the gaskets is 19 mm for ECOMAX..C and 22 mm for ECO-MAX..M. Design the length of the furnace extension **M1** so that the front edge of the recuperator is flush with the inside edge of the furnace lining (**S1** = 0 ± 20 mm).

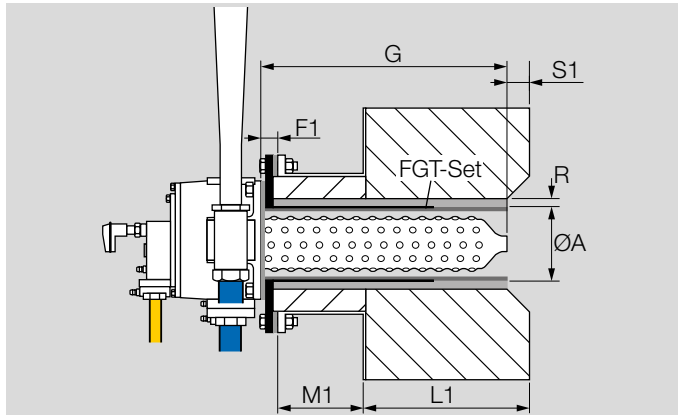

Burner	FGT outside diameter ØA in mm
ECOMAX 0C	142
ECOMAX 1C	180
ECOMAX 2C	200
ECOMAX 3C	236
ECOMAX 4C	300
ECOMAX 5C	336

Do not stress the flue gas guide tube with forces from the furnace lining.

The FGT must be wrapped in a ceramic fibre blanket provided by the customer during installation so that the hot furnace atmosphere cannot come into contact with the furnace wall or furnace extension. The installation opening in the furnace wall must be greater than the outside diameter **A** of the FGT.

Depending on the furnace lining and the type of expected movements in the furnace wall, the annular void **R** must be at least 25 mm. Use a larger annular void if necessary. Select the fibre blanket thickness to be around 20% larger than the annular void and compress it.

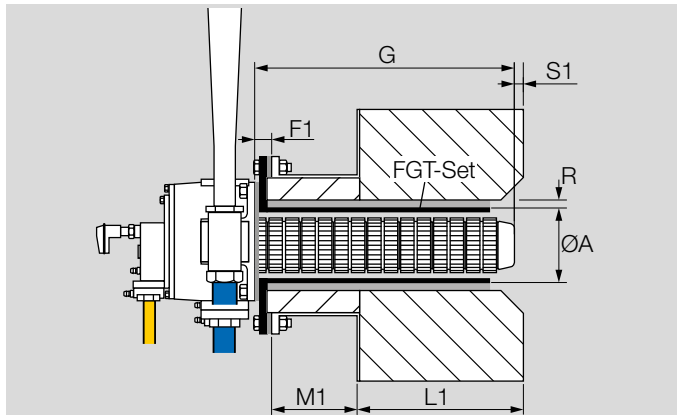

Burner	FGT outside diameter ØA in mm
ECOMAX 1M/ECOMAX 1F	133
ECOMAX 2M/ECOMAX 2F	156
ECOMAX 3M/ECOMAX 3F	193
ECOMAX 4M/ECOMAX 4F	254
ECOMAX 5M/ECOMAX 5F	287
ECOMAX 6M/ECOMAX 6F	390

6.3 Flue gas eductor EJEK

The flue gas eductor EJEK is available in 2 versions. The standard version EJEK is used with ECOMAX..M and ECOMAX..F. The high temperature version EJEK..-HT is designed for use with ECOMAX..C.

The eductors are used for flue gas extraction via the burner ECOMAX and cannot be used for furnace pressure control. It is recommended discharging 10 to 20% of the flue gases through an additional flue gas opening on the furnace fitted with a furnace pressure control system.

If the gas flue extraction rate is 80 to 90% at maximum furnace temperature, a positive furnace pressure will generally be maintained even at a low furnace temperature. In the case of heavily leaking furnaces, flue gas extraction must be reduced, where necessary, to avoid pulling in cold air due to negative pressure in the furnace chamber.

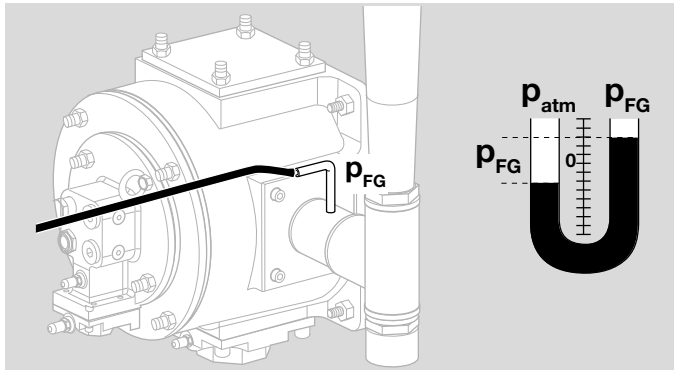

The motive air is set at the eductor by measuring the negative flue gas pressure p_{FG} between the burner and eductor.

If the furnace pressure is too high, damage can occur to burners which are switched off due to the flow of hot flue gases through the burners causing the burners to overheat. Eductors EJEK-AGK with a mechanical flue gas valve (AGK) must be used for direct heating to prevent flue gases creeping through the burner when it is switched off.

6.4 Flue gas system on the furnace

A flue gas system must be fitted on the furnace as a means of guiding the flue gas to the chimney. In the flue gas system, there should be a low negative pressure thanks to the draught of the chimney or an exhaust fan.

The flue gas system on the furnace should be fitted flush with the eductor (± 10 mm). The diameter of the flue gas pipe on the furnace should be twice the eductor diameter **P**. If the diameter is too small, there is the danger of hot flue gases creeping through the burner when it is switched off, even if it is equipped with an EJEK..AGK with a flue gas valve.

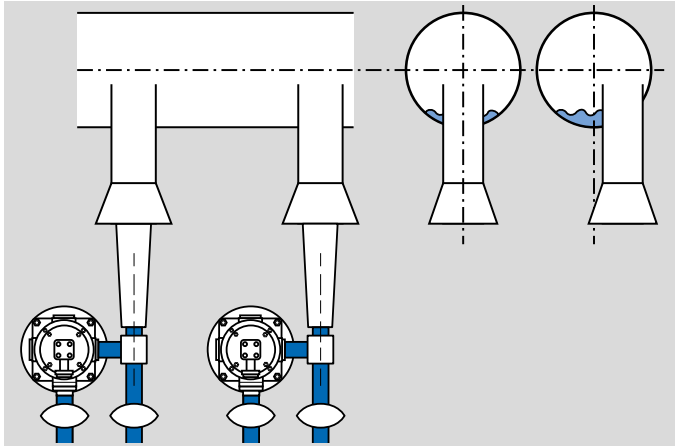

The spur lines from the flue gas manifold on the furnace to the various burners should be designed so that condensate cannot drip backwards into the burner.

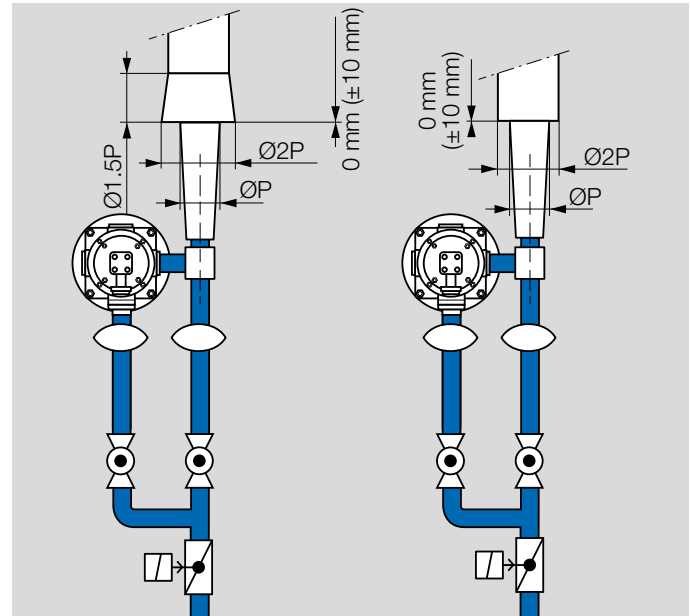

		ØP [mm]
ECOMAX 0	EJEK 0(B)	43
ECOMAX 1	EJEK 1	43
ECOMAX 2	EJEK 2(A)	83
ECOMAX 3	EJEK 3(A)	98
ECOMAX 4	EJEK 4(A)	128
ECOMAX 5	EJEK 5(A)	153
ECOMAX 6	EJEK 6(A)	215

6.5 Installation

6.5.1 Installation position

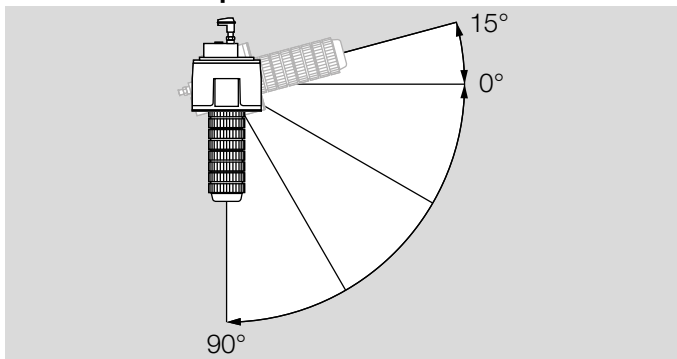

The burner ECOMAX may be installed as required between an angle of 0° (horizontal) and 90° (vertical from top to bottom). The ECOMAX may be angled upwards from the horizontal at a maximum angle of 15°.

Installation position of eductor EJEK: vertical, maximum angle 10°.

If the burner is installed at an angle of more than 10° to the vertical or horizontal, a special version of the flue gas eductor EJEK is required, which is available on request.

6.5.2 Tangential or angled burner installation

For a tangential or angled burner installation, make a recess in the furnace lining to allow the flue gas to be extracted smoothly. Take into account the very high outlet velocity of the burner when selecting the furnace lining for this area. In addition, the reflective radiation from the furnace wall onto the burner must be considered.

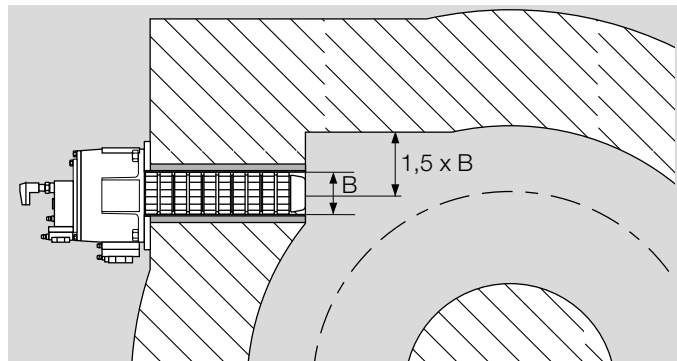

6.5.3 Clearances

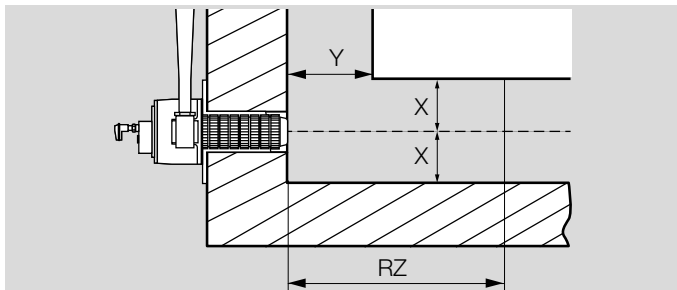

Plan for adequate clearances to the charge and the interior furnace wall to ensure complete combustion and avoid local overheating. The high level of air preheating achieved by the ECOMAX also means that the flame has a higher temperature.

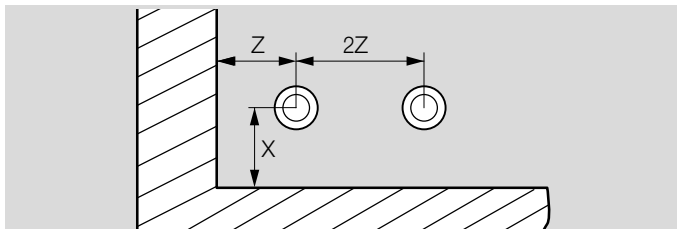

The minimum side clearance between two burners or between a burner and the furnace side wall is calculated using the geometric dimensions of the burner with eductor. It should also be noted that burners positioned opposite each other may cause the recuperator heads to overheat.

Flame mode

Burner	Reaction zone RZ [mm]	Distance [mm]	
		X	Z
ECOMAX 0	500	130	270

Burner	Reaction zone RZ [mm]	Distance [mm]	
		X	Z
ECOMAX 1	700	155	270
ECOMAX 2	900	200	285
ECOMAX 3	1200	250	300
ECOMAX 4	1600	340	350
ECOMAX 5	1800	400	400
ECOMAX 6	2200	570	570

A sufficiently large reaction zone (RZ) and undisturbed recirculation of the flue gas into the reaction zone are required for menox® low NO_x mode. Operation in very small combustion chambers leads to an increase in NO_x emissions.

menox® low NO_x mode

Burner	Reaction zone RZ [mm]	Distance [mm]		
		X	Y	Z
ECOMAX 3M	2100	300	320	300
ECOMAX 4M	2800	360	400	360
ECOMAX 5M	3300	400	480	400

6.5.4 Furnace chamber temperature measurement

The furnace chamber temperature measurement must be representative for the flue gas temperature around the extraction system on the burner. If the measurement is not representative, there is a danger that the recuperator head will overheat.

6.5.5 Heat guard

During operation, the burner body and eductor or flue gas connector can reach surface temperatures of over 80°C.

The burner, eductor and flue gas connector must not be insulated as otherwise the material will overheat.

We recommend that warning signs and a contact guard be fitted, for example made of perforated sheet metal.

6.6 Flame control

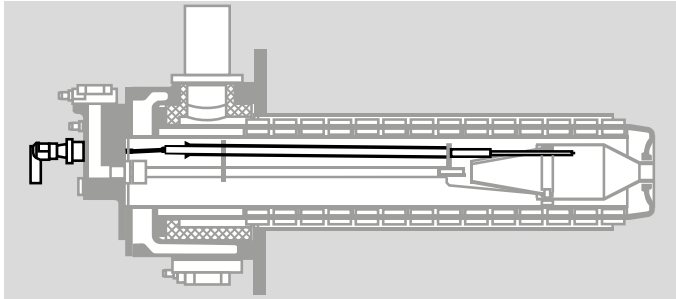

The burners ECOMAX are equipped with a combined spark electrode/flame rod. Ionization control is possible with direct heating up to a temperature of around 1150°C (single-electrode operation). It should be ensured that the burner control unit BCU must at least have firmware version FW 16xx, see page 38 (6.7 Burner control units and ignition transformers).

Flame control with a UV sensor is necessary if a furnace temperature of 1150°C is exceeded for direct heating.

As from a furnace temperature of 1050°C, we recommend the use of bend-resistant Kanthal electrodes for ignition for the ECOMAX..M. These are installed as standard in the ECOMAX..C.

A UV sensor UVS 10D1 with an integrated purge air connection (Order No. 84315202) it is recommended for UV control.

For the ECOMAX 0, the UV sensor UVS 10L1 (Order No. 84315203) with a lens is required for UV control. UV sensor UVS 10L1 (Order No. 84315203) with a lens is also required for UV control for burners ECOMAX 1–6 with a burner length of over 545 mm.

An adapter is required to install the UVS 10, see page 61 (8.4 UV adapter set).

6.7 Burner control units and ignition transformers

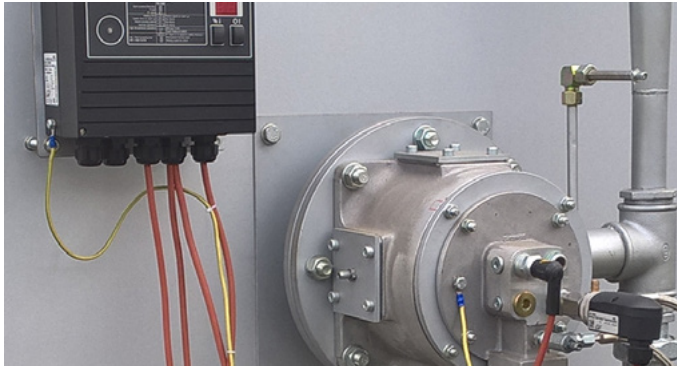

ECOMAX burners with burner control unit BCU

The ECOMAX burners are designed for ON/OFF operation. We recommend burner control unit BCU 460 or BCU 465 (from 2019).

The ECOMAX burners require an ignition transformer with 7.5 kV high voltage and an output current of 20 mA for ignition. An appropriate ignition transformer is already integrated in burner control units BCU 460 and BCU 465. For recommended parameters, page 39 (6.7.1 Configurations for burner control unit).

For further information on burner control units and ignition transformers, see [Technical Information BCU 460, 465 \(2019\)](#).

6.7.1 Configurations for burner control unit

The following tables apply to BCU 460, 465 (2019).

Description	Configuration D1	Configuration D2	Configuration D3	Configuration D4
Flame control	ionization	UVS 10	ionization	UVS 10
Pneumatic air/gas ratio control	VAH/VAG		None/VAH/VAG	
Air flow monitoring	–		Differential pressure switch PDZ	

Hardware	BCU 460..F3	BCU 460..F3	BCU 465..F3	BCU 465..F3
Ignition transformer	8 = 8 kV, 33% DC	8 = 8 kV, 33% DC	8 = 8 kV, 33% DC	8 = 8 kV, 33% DC
Rewiring for electrode operation	1 electrode	2 electrodes	1 electrode	2 electrodes

Description	Parameter	Configuration D1	Configuration D2	Configuration D3	Configuration D4
Switch-off threshold of the flame amplifier	A001	4 μ A	4 μ A	4 μ A	4 μ A
Burner application	A078	1	1	1	1
Air flow monitoring during purging	A101	N/A	N/A	7	7
Delayed air flow monitoring	A016	N/A	N/A	1	1
Safety time during operation t_{SB} for V1 and V2	A019	1	1	1	1
Minimum burner on time t_B	A061	8	8	8	8
Running time	A042	4	4	4	4
Safety time on start-up t_{SA}	A094	3	3	3	3
Air valve control	A048	1	1	1	1
Low fire over-run time t_{KN} after a controlled shut-down	A043	N/A	N/A	0	0
Pre-ventilation time t_{VL} before start-up	A036	N/A	N/A	0	0
Pre-purge time t_{pV} after safety shut-down	A034	N/A	N/A	0	0

BCU for direct heating	Configuration D1	Configuration D2	Configuration D3	Configuration D4
230 V	88681446*	88681446	88681452*	88681452
230 V, PROFIBUS**	88681447*	88681447	88681453*	88681453
230 V, PROFINET**	88681458*	88681458	88681461*	88681461
230 V, HT operation	88681448*	88681450	88681454*	88681456
230 V, HT operation, PROFIBUS**	88681449*	88681451	88681455*	88681457
230 V, HT operation, PROFINET**	88681459*	88681460	88681462*	88681463

* Rewiring for single-electrode operation required on site.

** Order a suitable bus module.

6.8 Gas connection

6.8.1 Component selection

A pneumatically operated gas/air ratio regulator combined with a slow opening air valve must always be used to ensure a safe burner start. If no pneumatic ratio control system is used, a slow opening gas valve and a quick opening air valve must be installed.

The following gas control valves are recommended for natural gas:

Burner	Flow rate control	Air/gas ratio control	No pneumatic ratio control system
ECOMAX 0	VAS 115..N + VAH 115..B + VMV 115	VAS 115..N + VAG 115..B + VMV 115	VG 15..N + VG 15..L + VMV 115
ECOMAX 1	VAS 115..N + VAH 115..B + VMV 115	VAS 115..N + VAG 115..B + VMV 115	VG 15..N + VG 15..L + VMV 115
ECOMAX 2	VAS 115..N + VAH 115..B + VMV 115	VAS 115..N + VAG 115..B + VMV 115	VG 15..N + VG 15..L + VMV 115
ECOMAX 3	VAS 115..N + VAH 115..B + VMV 115	VAS 115..N + VAG 115..B + VMV 115	VG 15..N + VG 15..L + VMV 115
ECOMAX 4	VAS 120..N + VAH 120..A + VMV 120	VAS 120..N + VAG 120..B + VMV 120	VAS 120..N + VAS 120..L + VMV 120
ECOMAX 5	VAS 125..N + VAH 125..A + VMV 125	VAS 125..N + VAG 125..B + VMV 125	VAS 125..N + VAS 125..L + VMV 125

A bellows unit EKO should be installed between the burner and controls to rule out the possibility of force acting on the burner.

A connection set with 6 x 1 compression fittings is available for connecting the VAH control line, see page 61 (8.3

VAH connection set). This set is installed on the burner before delivery.

6.8.2 Gas pressure

The required gas pressure depends on the burner size, gas type and system design.

	Gas pressure upstream of burner [mbar]	Gas supply pressure*	
		Natural gas H [mbar]	Natural gas L/ LPG [mbar]
Flow rate control	50–65	100	120
Air/gas ratio control**	50–65	100	120
No pneumatic ratio control system	50–65	80	100

* If a stainless steel flexible tube ES is used instead of the stainless steel bellows unit EKO, a higher pressure loss must be taken into account.

** The gas supply pressure must be at least 10–20 mbar above the air supply pressure.

6.8.3 Operation with LPG

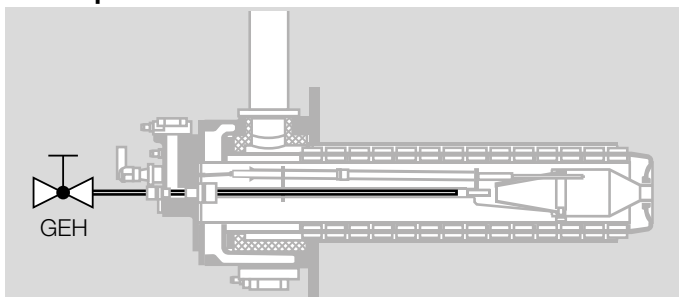

For operation with LPG, it is essential to cool the gas lance via a central air lance in order to prevent the LPG from cracking in the gas lance and soot formation during combustion.

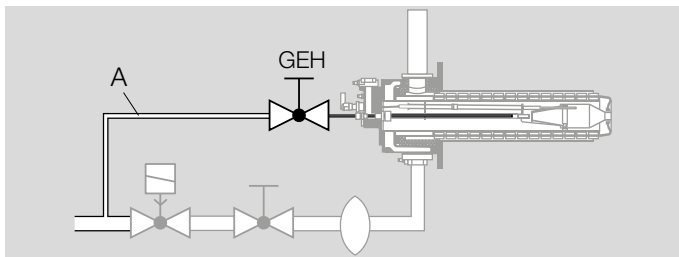

Size of central air connection A

Type	A
ECOMAX 0	1/4"
ECOMAX 1	1/4"
ECOMAX 2	1/4"
ECOMAX 3	1/4"
ECOMAX 4	1/2"
ECOMAX 5	1/2"

The central air volume is approx. 3 to 5% of the combustion air volume and must also flow while the burner is switched off.

Fully open the adjuster GEH in the central air lance. On the ECOMAX 1, the adjuster must be restricted to 45° or 50%.

If high temperature operation without flame control using ionization or a UV sensor is intended for LPG, air flow monitoring using the air flow detector set ECO must be provided to prevent backflow of the central air into the gas line or of gas into the air line in the event of the flue gas route being blocked.

6.9 Air connection

6.9.1 Component selection

Slow opening air valves or butterfly valves with a solenoid actuator are required for a pneumatic ratio control system. Quick opening air valves or solenoid actuators must be used for system designs without a pneumatic ratio control system. The following air control valves are recommended for air:

Burner	Flow rate control/ Air/ gas ratio control	No pneumatic ratio control system
ECOMAX 0	VAA 240..L	VAA 240..N
ECOMAX 1	VAA 350..L	VAA 350..N
ECOMAX 2	BVHM 50 + MB 7..L	BVHM 50 + MB 7..N
ECOMAX 3	BVHM 65 + MB 7..L*	BVHM 65 + MB 7..N
ECOMAX 4	BVHM 80 + MB 7..L*	BVHM 80 + MB 7..N
ECOMAX 5	BVHM 80 + MB 7..L*	BVHM 80 + MB 7..N

* For menox: MB 7..N

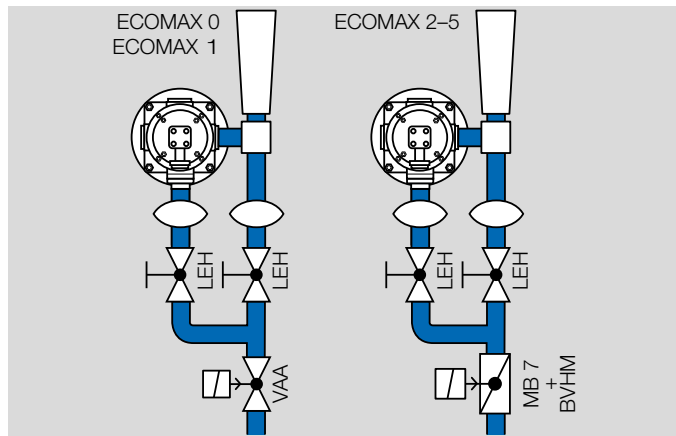

6.9.2 Air pressure

The motive air at eductor EJEK is extremely important for designing the air supply. The required pressure depends on the burner capacity, flue gas extraction through the burner and the furnace chamber temperature:

	Motive air pressure upstream of the eductor*	Air supply pressure*
ECOMAX 0 und 1 at a furnace chamber temperature of 1000°C	approx. 100 mbar	approx. 115 mbar
ECOMAX 2C–5C with EJEK..HT-A (constr. A) at a furnace chamber temperature of 1250°C	approx. 65 mbar	approx. 80 mbar
ECOMAX 2M–6M with EJEK..A (constr. A) at a furnace chamber temperature of 1100°C	approx. 65 mbar	approx. 80 mbar

* Air pressures for burner rated capacities at the specified furnace chamber temperatures and 80% flue gas extraction.

Flow rate curves are available in the Docuthek for EJEK version A for precise design purposes.

An uninhibited flow is required to ensure accurate measurements of the pressure differential on the integrated orifice. We recommend that you use the air connection set which will ensure an accurate measurement at the orifice, see page 61 (8.1 Air connection set). The attachment of a coupling, a bellows unit or a pipe elbow directly upstream of the orifice can cause turbulence in the gas flow resulting in the burner being incorrectly adjusted.

6.10 Air flow monitoring

An air flow monitor is recommended to act as a low pressure protection device (pursuant to EN 746-2 and

ISO 13577-2) in systems without pneumatic ratio control system. It is achieved using a differential pressure switch at the air connection combined with a burner control unit BCU 465. An accessory set to monitor the air flow is available for this purpose, see page 61 (8.2 Air flow detector set).

6.11 Purge air and cooling air

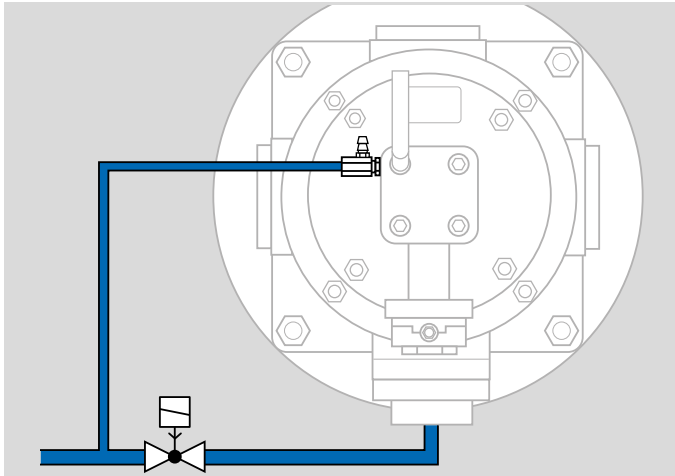

The purge air must be connected to the burner ECOMAX in order to ensure safe ignition and monitoring, and in order to avoid problems caused by condensation and/or overheating.

The required purge air volume is approx. 0.5 to 1.0% of the air volume for rated capacity, but subject to a minimum of 1 m³_(st)/h.

The purge air is connected to the gas connection flange next to the electrode or, with UV control, to the purge air connection of the UV sensor. The purge air is tapped upstream of the air control valve so that the purge air continues to flow even if the burner is switched off.

To limit the volume of purge air, special nozzles can be used which are adjusted to the required air supply pressure for the ECOMAX – see page 62 (8.5 Purge air/cooling air nozzles).

Burner	Nozzle for electrode purge	Purge air nozzle on UV sensor
ECOMAX 0	Nozzle electrode ECO 0 Rp 1/4 D=2.5 /E	Nozzle UV ECO 0–3 Rp 1/4 D=2.5 /B
ECOMAX 1–3	Nozzle electrode ECO 1–3 Rp 1/4 D=2.5 /E	Nozzle UV ECO 0–3 Rp 1/4 D=2.5 /B
ECOMAX 4–6	Nozzle electrode ECO 4–6 Rp 1/4 D=4.0 /E	Nozzle UV ECO 4–6 Rp 1/4 D=4.0 /B

In very high furnace chamber temperatures, we recommend that the burner head is cooled by selecting a larger nozzle or a supply line of D = 8 mm without a nozzle.

6.12 Condition on delivery

The gas and air connection and the flue gas connection can be aligned to suit the order based on the intended installation on the furnace. The positions of the connections are coded with numbers 0, 3, 6 and 9.

Identifier	Position of the connections
0	top
3	right-hand side
6	bottom
9	left-hand side

The identifiers for the positions of the connections are stated in the sequence flue gas – air – gas.

If there is no specification, the burners are supplied as follows:

ECOMAX../D for direct heating with a connector position 366, in other words with the flue gas connection for eductor installation on the right and the gas and air connection at the bottom.

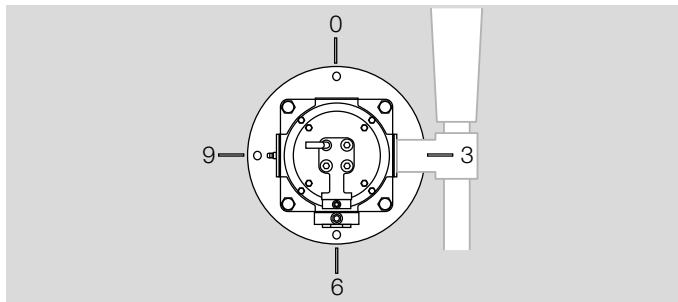

The FGT set..D for direct heating is installed on the burner at the factory as long as it is ordered at the same time as the burner. This also applies to all add-on parts with the designation /E, such as the air flow detector set, UV adapter set,

purge air nozzle and inlet section for gas and air, see page 61 (8 Accessories).

6.13 Cooling mode with ECOMAX

The extraction of the gases through the burner and therefore the preheating of the combustion air can be disabled to ensure controlled furnace cooling. Instead of a butterfly valve for air, separate valves for combustion air and motive air should be installed for this purpose. In this case, a separate flue gas route should be opened on the furnace through which the cooling air is removed from the furnace.

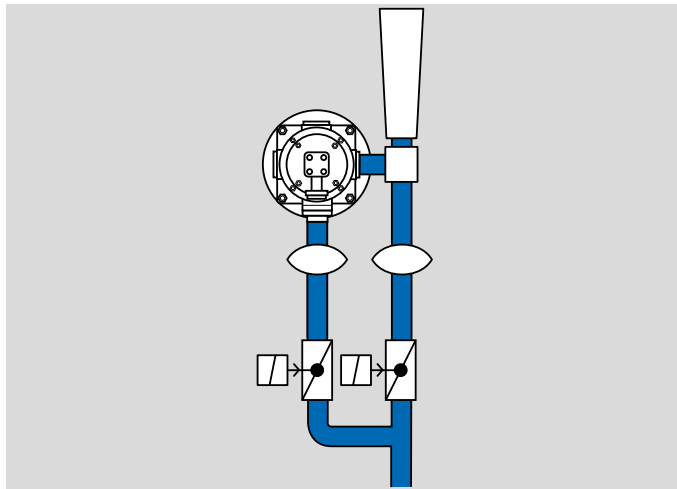

6.14 Emissions

The CO and NO_x values depend on the furnace chamber temperature, air preheating, burner type and burner settings (NO_x values available on request).

If operated with LPG, the NO_x values are approx. 25% higher.

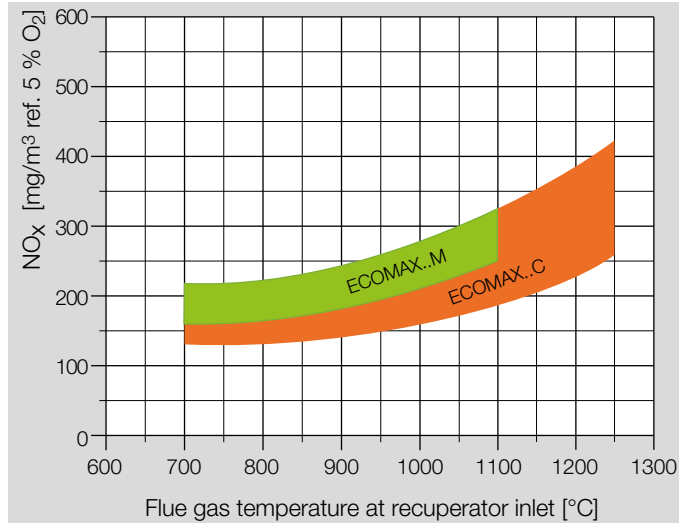

NO_x values in the diagram apply to natural gas

The CO emissions depend on the burner operating mode and flue gas temperature at the recuperator inlet:

- for continuous operation with a flue gas temperature of around 600°C or over upstream of the recuperator below 10 ppm
- for intermittent operation with a flue gas temperature of around 750°C or over upstream of the recuperator below 10 ppm

6.15 Build up of noise

The sound pressure level of an open burning flame may be significantly above 90 dB(A) as a result of the high flame velocity. When the burner is installed, the sound pressure level of the individual burner which can be measured outside the furnace is generally between 75 and 82 dB(A).

The measurable value on a furnace system depends on the capacity, excess air, flue gas extraction and flue gas temperature of the individual burners and on the burner layout and ambient influences (Sound pressure level on request).

6.16 Process constraint

With direct heating, the flue gases are routed out of the furnace chamber through the burner. Impurities from the process may affect the burner operation.

Dust

Dust or degassing components from the charge (for example molybdenum) may be deposited on the recuperator. In this case, the volume of flue gas guided through the recuperator will fall as will the efficiency level of the burner. In addition, this may result in increased furnace pressure and damage to the furnace and burner. In this case, increased maintenance work and reduced cleaning intervals are required.

Chemical attack

Other impurities such as alkalis from the heating of castings or from cooling and washing fluids may cause a chemical attack on the material. In this case, the service life of the recuperator and flue gas guide tube will be reduced. We therefore advise against its use in forging and heating furnaces in which raw material is heated. We also advise

against its use in aluminium smelting furnaces as a result of the dusty furnace atmosphere, the risk of liquid metal spatter and possible chemical attack.

Sub-stoichiometric burner operation

Avoid sub-stoichiometric burner operation. A reducing atmosphere may damage the insulation in the burner on the flue gas side, the metallic recuperator and flue gas guide tube and the vacuum-formed part in the flue gas guide tube for ECOMAX..C.

6.17 Resistance of SiSiC

The ceramic recuperator of the ECOMAX..C consists of reaction-bound silicon carbide (SiSiC) infiltrated with metallic silicon. During the manufacturing process, a protective layer made of SiO₂ is formed on the surface, which ensures good chemical resistance.

When installing the burners, it must be ensured that the protective layer on the ceramic surface is not damaged.

The burners should be adjusted with excess air of 1–5% O₂ in the flue gas to maintain the protective layer. In the case of sub-stoichiometric burner operation (CO concentration > 1000 ppm), white deposits can build up on the SiSiC over a long period of time. This reduces the service life of the ceramic.

Impurities such as fluorine, chlorine and alkali compounds (e.g. with sodium or potassium) in the furnace atmosphere also cause a chemical attack on the material and reduce the service life of the ceramic recuperator. We therefore advise against its use in forging and heating furnaces in which raw material is heated. We also advise against its use in aluminium smelting furnaces.

7 Radiant tube heating project planning information

7.1 Heat design

When designing a radiant tube heating system, it must be noted that the energy can be transferred to the furnace chamber through the surface of the radiant tube so that the maximum flue gas temperature at the burner's recuperator inlet is not exceeded.

In addition, it must be noted that the maximum material temperature of the radiant tube and the flame tube on single ended radiant tubes is not exceeded.

Burner	Max. flue gas temperature at recuperator inlet	
	[°C]	[°F]
ECOMAX..C	1250	2282
ECOMAX..M/ECOMAX..P	1150	2102
ECOMAX..F	1050	1922

The possible radiation output in the furnace depends on the furnace chamber temperature and the radiant tube surface as well as the material used for the radiant tube and burner.

The burner capacity is also dependent on the efficiency of the burner.

The heat exchange level must be calculated to design an indirect heating system correctly; please contact a sales executive.

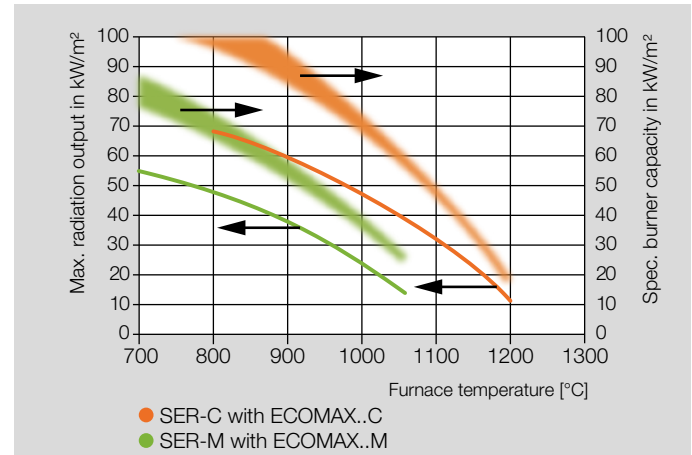

Depending on the system configuration, it may be necessary to reduce the energy supply depending on the furnace chamber temperature, for example by reducing the duty cycle. Depending on the burner capacity and size of the radiant tube, the burner on time must be limited to prevent subjecting the radiant tube and burner to a thermal overload.

Calculated data relating to the duty cycle are available from your sales executive on request.

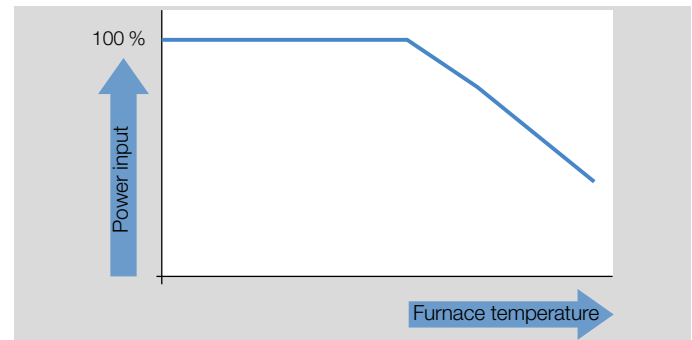

7.2 Radiant tubes

For ECOMAX..C

The burners ECOMAX..C are designed for use in combination with ceramic radiant tubes SER-C.

See [Technical Information SER-C](#).

Standard combinations:

Radiant tube	Burner	Segmented flame tube
SER-C 100/088	ECOMAX 0C	SICAFLEX 100/088/084
SER-C 142/128	ECOMAX 1C	SICAFLEX 142/127/123
SER-C 162/148	ECOMAX 2C	SICAFLEX 162/147/143
SER-C 202/188	ECOMAX 3C	SICAFLEX 202/186/182

In special cases, a ceramic burner ECOMAX..C can be installed in a metallic radiant tube. However, external forces on the ceramic burner must be excluded by the deformation of the radiant tube.

If the inside diameter of the radiant tube is significantly larger than the outside diameter of the recuperator, an additional flue gas guide tube FGT set should be used, see page 67 (8.12 Flue gas guide tube FGT set).

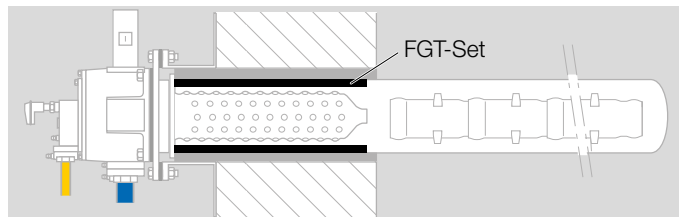

For ECOMAX..M

Metallic radiant tubes are available in a variety of dimensions in either centrifugal casting or in welded form. The efficiency of the burner ECOMAX..M is determined by the

inside diameter d_i of the radiant tubes in the vicinity of the burner. The following dimensions are recommended:

Burner	Minimum radiant tube inside diameter d_i [mm]	Flue gas guide tube FGT set is recommended from a radiant tube inside diameter d_i [mm]
ECOMAX 1M	128	140
ECOMAX 2M	147	164
ECOMAX 3M	185	202
ECOMAX 4M	248	266
ECOMAX 5M	280	298

If the inside diameter of the radiant tube is significantly larger than the outside diameter of the recuperator, an additional flue gas guide tube FGT set should be used. Install the FGT set wrapped in a fibre blanket.

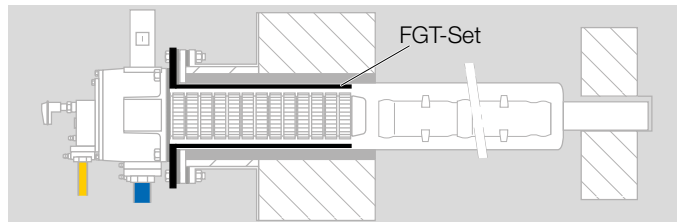

Depending on the geometry, additional adapter flanges may be required for radiant tubes.

7.3 Flue gas channelling

A flue gas connector FLUP is used as standard to remove the flue gases for indirect heating, and must be ordered separately. In special cases, an eductor EJEK can also be used to remove the flue gas. This must also be ordered separately.

Flue gas connector FLUP

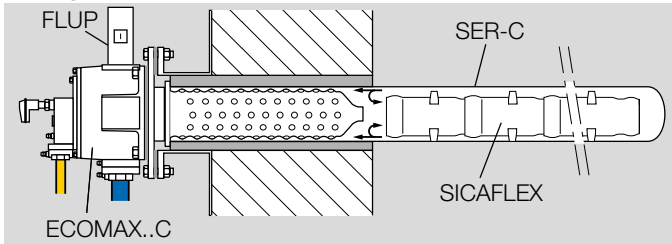

The flue gas connector FLUP is designed to discharge the flue gases into the flue gas system on the furnace and has an opening with a clip to connect flue gas analysis equipment.

Eductor EJEK

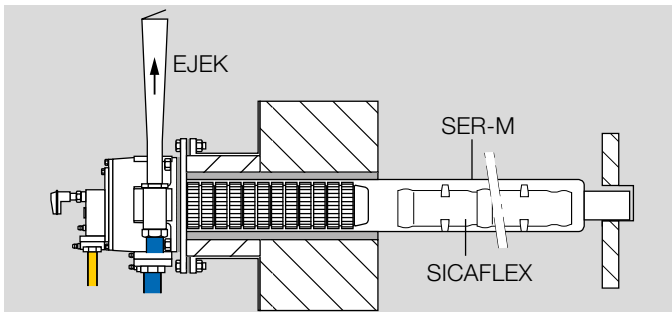

In indirect heating systems with metallic radiant tubes, eductor EJEK can generate a negative pressure in the ra-

diant tube. This prevents the inert gas atmosphere in the furnace being contaminated by flue gases from the burner in the event of leakage from the single ended radiant tube.

7.4 Flue gas system on the furnace

A flue gas system must be fitted on the furnace as a means of guiding the flue gas to the chimney. In the flue gas system, there should be a low negative pressure thanks to the draught of the chimney or an exhaust fan.

The spur lines from the flue gas manifold on the furnace to the various burners should be designed so that condensate cannot drip backwards into the burner.

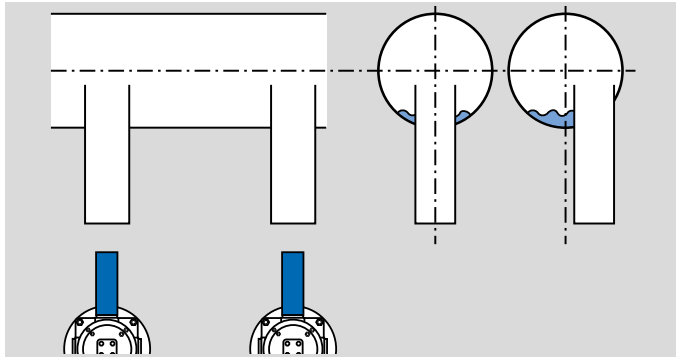

The spur lines to the burner should stop 10 mm away from the flue gas connector FLUP or be fitted flush with the eductor EJEK.

For radiant tube heating with flue gas monitoring kit DW and BCU 465, excessive negative pressure in the flue gas system or an excessively narrow flue gas pipe diameter on the furnace can cause problems with setting the switching point of the pressure switch.

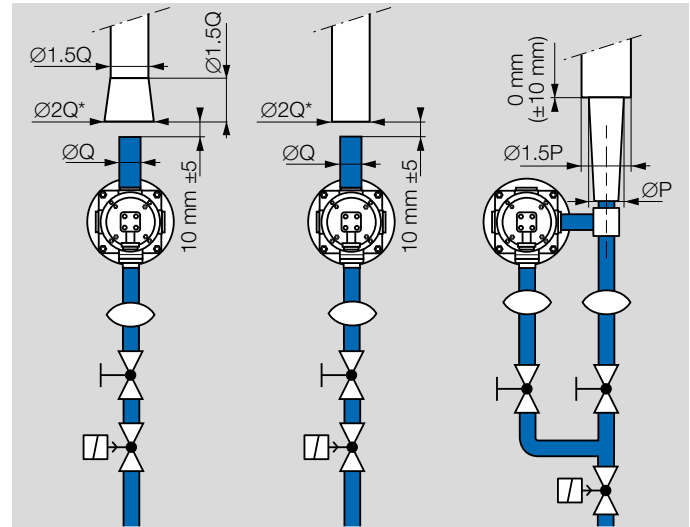

* With flue gas monitoring kit DW; without flue gas monitoring kit DW: 1.5Q to 2Q.

	FLUP ØQ	EJEK ØP [mm]
ECOMAX 0	DN 32	43
ECOMAX 1	DN 50	43
ECOMAX 2	DN 50	83
ECOMAX 3	DN 65	98
ECOMAX 4	DN 100	128
ECOMAX 5	DN 100	153

For sealed flue gas systems, a pressure regulator is to be fitted in the flue gas system. The gas and air flow rates depend on the total pressure differential between the supply and flue gas systems. If the pressure in the flue gas system fluctuates, the burner capacity will change and the lambda value may shift if the system is not equipped with air/gas ratio control.

7.5 Installation

Installation position of burner with FLUP: horizontal, vertical-downwards and angled downwards.

Ensure adequate distances between the radiant tubes and to the furnace wall to prevent local overheating.

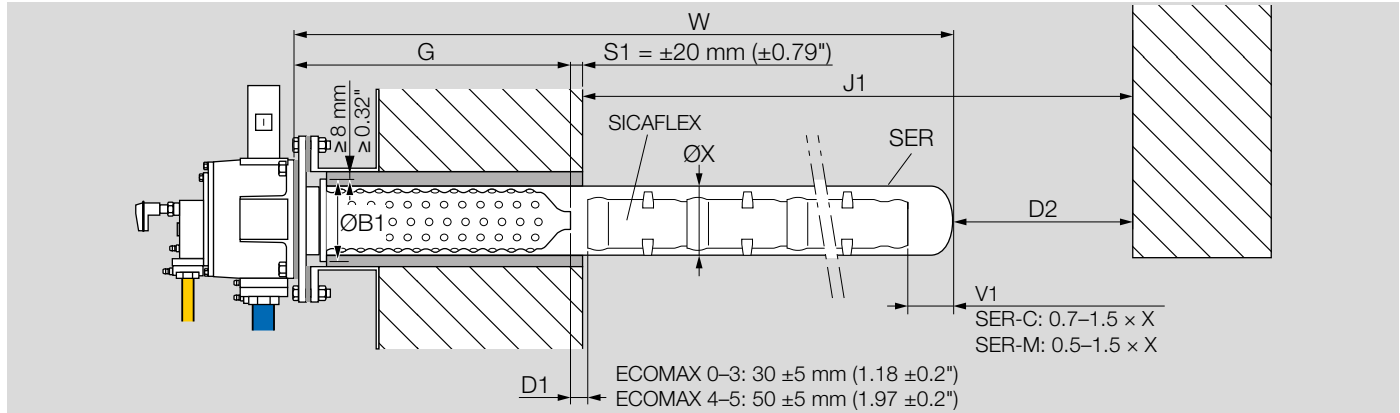

Leave a recirculation gap **D1** (30 mm for ECOMAX 0–3 or 50 mm for ECOMAX 4–5) between the burner and flame tube, e.g. SICAFLEX. The deflector gap **V1** should be around 0.7 to 1.5 times (SER-C) or 0.5 to 1.5 times (SER-M) the diameter **X** of the radiant tube.

SER-C

The length **W** of the radiant tube SER-C depends on the clear furnace width (furnace height) **J1** and the burner length **G**.

$$W \leq J1 + G + S1 - D2 \quad (D2 \geq 40 \text{ mm})$$

The minimum length of the radiant tube depends on the burner length **G** and the flame length.

$$W > G + 2 \times \text{flame length}$$

For further information on the design of the radiant tube, see [Technical Information SER-C](#).

SER-M

Calculate the minimum possible length **W** of the SER-M using a heat design (contact a member of our sales team).

7.5.1 Heat guard

During operation, the burner body and flue gas connector or eductor can reach surface temperatures of over 80°C. The burner, flue gas connector and eductor must not be insulated as otherwise the material will overheat.

We recommend that warning signs and a contact guard be fitted, for example made of perforated sheet metal.

7.6 Flame control

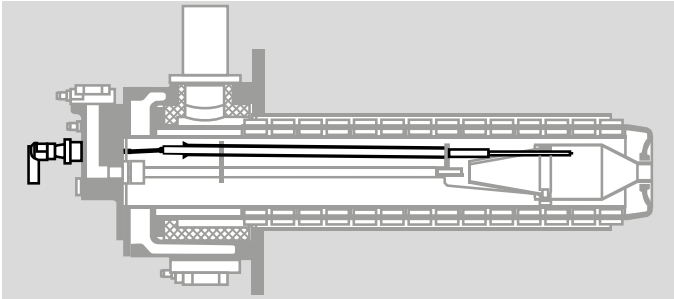

The burners ECOMAX are equipped with a combined spark electrode/flame rod. Ionization control is possible with radiant tube heating up to a furnace temperature of around 1050°C (single-electrode operation).

Flame control with a UV sensor is necessary if a furnace temperature of 1050°C is exceeded for indirect heating. As from a furnace temperature of 950°C, we recommend the use of bend-resistant Kanthal electrodes for ignition for the ECOMAX..M. These are installed as standard in the ECOMAX..C.

A UV sensor UVS 10D1 with an integrated purge air connection (Order No. 84315202) it is recommended for UV control.

For the ECOMAX 0, the UV sensor UVS 10L1 (Order No. 84315203) with a lens is required for UV control. UV sensor UVS 10L1 (Order No. 84315203) with a lens is also required for UV control for burners ECOMAX 1–6 with a burner length of over 545 mm.

An adapter is required to install the UVS 10, see page 61 (8.4 UV adapter set).

7.7 Burner control units and ignition transformers

The ECOMAX burners are designed for ON/OFF operation. We recommend burner control units BCU 465. The burner control units must have firmware FW 16xx or higher to implement ionization control up to 1050°C.

After a safety shut-down, air should always be supplied to purge the radiant tube.

The ECOMAX burners require an ignition transformer with 7.5 kV high voltage and an output current of 20 mA for ignition. An appropriate ignition transformer is already integrated in burner control units BCU 460 and BCU 465. For recommended parameters, see page 54 (7.7.1 Configurations for burner control unit).

For further information on burner control units and ignition transformers, see [Technical Information BCU 460, 465 \(2019\)](#).

7.7.1 Configurations for burner control unit

The following tables apply to BCU 460, 465 (2019).

Description	Configuration R1	Configuration R2
Flame control	Ionization	UVS 10
Pneumatic air/gas ratio control	None/VAG	None/VAG
Air flow monitoring	Differential pressure switch PDZ	Differential pressure switch PDZ

Hardware	BCU 465..F3	BCU 465..F3
Ignition transformer	8 = 8 kV, 33% DC	8 = 8 kV, 33% DC
Rewiring for electrode operation	1 electrode	2 electrodes

Description	Parameter	Configuration R1	Configuration R2
Switch-off threshold of the flame amplifier	A001	4 μ A	4 μ A
Burner application	A078	1	1
Air flow monitoring during purging	A101	7	7
Delayed air flow monitoring	A016	1	1
Safety time during operation t_{SB} for V1 and V2	A019	1	1
Minimum burner on time t_B	A061	8	8
Running time	A042	4	4
Safety time on start-up t_{SA}	A094	3	3
Air valve control	A048	1	1
Low fire over-run time t_{KN} after a controlled shut-down	A043	0	0
Pre-ventilation time t_{VL} before start-up	A036	0	0
Pre-purge time t_{pV} after safety shut-down	A034	7	7

BCU for radiant tube heating	Configuration R1	Configuration R2
230 V	88681464*	88681464
230 V, PROFIBUS	88681465*	88681465
230 V, PROFINET	88681470*	88681470
230 V, HT operation	88681466*	88681468
230 V, HT operation, PROFIBUS	88681467*	88681469
230 V, HT operation, PROFINET	88681471*	88681472

* Rewiring for single-electrode operation required on site.

** Order a suitable bus module.

7.8 Gas connection

7.8.1 Component selection

A slow opening gas valve must always be used to ensure a safe burner start for indirect heating.

The following gas control valves are recommended for natural gas:

Burner	No pneumatic ratio control system	Air/gas ratio control
ECOMAX 0	VG 15..N + VG 15..L + GEH 15	VAG 115..B + VG 15..L + VMV 115
ECOMAX 1	VG 15..N + VG 15..L + GEH 15	VAG 115..B + VG 15..L + VMV 115
ECOMAX 2	VG 15..N + VG 15..L + GEH 15	VAG 115..B + VG 15..L + VMV 115
ECOMAX 3	VG 15..N + VG 15..L + GEH 15	VAG 115..B + VG 15..L + VMV 115
ECOMAX 4	VAS 120..N + VAS 120..L + VMV 120	VAG 120..B + VAS 120..L + VMV 120
ECOMAX 5	VAS 125..N + VAS 125..L + VMV 125	VAG 125..A + VAS 125..L + VMV 125

A bellows unit EKO should be installed between the burner and controls to rule out the possibility of force acting on the burner.

7.8.2 Gas pressure

The required gas pressure depends on the burner size, gas type and system design.

	Gas pressure upstream of burner	Gas supply pressure*	
		Natural gas H	Erdgas L/ LPG
Air/gas ratio control	65–70 mbar	100 mbar	120 mbar
No pneumatic ratio control system	65–70 mbar	80 mbar	100 mbar

* If a stainless steel flexible tube ES is used instead of the stainless steel bellows unit EKO, a higher pressure loss must be taken into account.

7.8.3 Operation with LPG

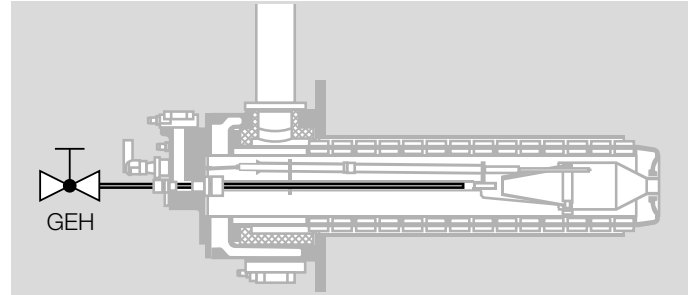

For operation with LPG, it is essential to cool the gas lance via a central air lance in order to prevent the LPG from cracking in the gas lance and soot formation during combustion.

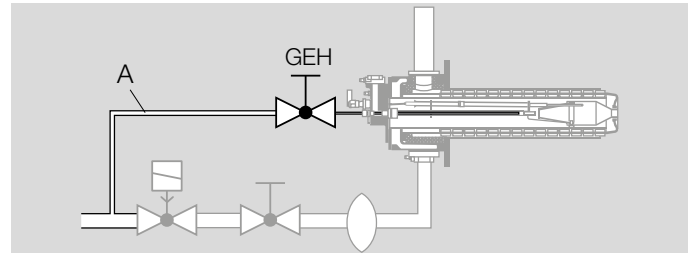

Size of central air connection A

Type	A
ECOMAX 0	1/4"
ECOMAX 1	1/4"
ECOMAX 2	1/4"
ECOMAX 3	1/4"
ECOMAX 4	1/2"
ECOMAX 5	1/2"

7 Radiant tube heating project planning information

The central air volume is approx. 3 to 5% of the combustion air volume and must also flow while the burner is switched off.

Fully open the adjuster GEH in the central air lance. On the ECOMAX 1, the adjuster must be restricted to 45° or 50%.

If high temperature operation without flame control using ionization or a UV sensor is intended for LPG, air flow monitoring using the air flow detector set ECO must be provided to prevent backflow of the central air into the gas line or of gas into the air line in the event of the flue gas route being blocked.

7.9 Air connection

7.9.1 Component selection

A quick opening air valve must always be used to ensure a safe burner start for indirect heating. The following air valves and butterfly valves/solenoid actuators are recommended:

Burner	No pneumatic ratio control system	Air/gas ratio control
ECOMAX 0	VAA 125..N	VAA 125..N
ECOMAX 1	VAA 125..N	VAA 125..N
ECOMAX 2	VAA 240..N	VAA 240..N
ECOMAX 3	VAA 350..N	VAA 350..N
ECOMAX 4	BVHM 50/MB 7..N	BVHM 50/MB 7..N
ECOMAX 5	BVHM 65/MB 7..N	BVHM 65/MB 7..N

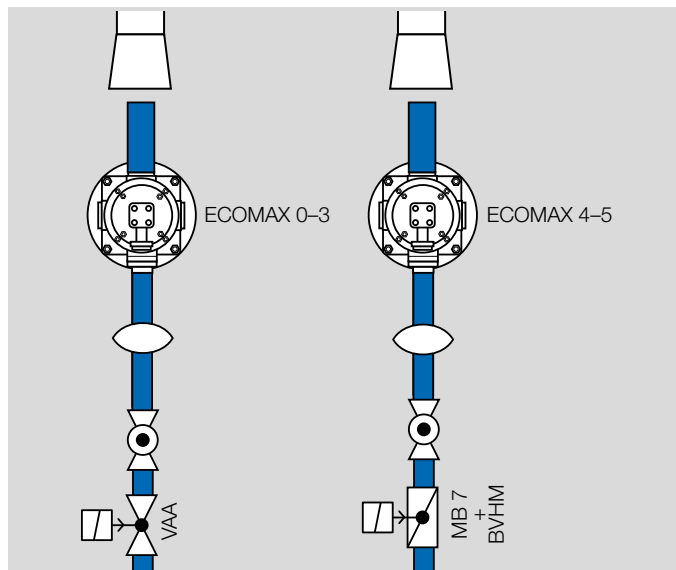

7.9.2 Air pressure

The required air pressure depends on the burner size, gas type and system structure:

	Air pressure upstream of burner [mbar]	Air supply pressure	
		Natural gas H [mbar]	Natural gas L/ LPG [mbar]
Air/gas ratio control	approx. 50–60	80	100
No pneumatic ratio control system	approx. 50–60	80	80

An uninhibited flow is required to ensure accurate measurements of the pressure differential on the integrated orifice. We recommend that you use the air connection set which will ensure an accurate measurement at the orifice, see page 61 (8.1 Air connection set). The attachment of a coupling, a bellows unit or a pipe elbow directly upstream of the orifice can cause turbulence in the gas flow resulting in the burner being incorrectly adjusted.

7.10 Air flow monitoring

An air flow monitor is recommended to act as a low pressure protection device (pursuant to EN 746-2 and ISO 13577-2) in systems without pneumatic ratio control system. It is achieved using a differential pressure switch at the air connection combined with a burner control unit BCU 465. An accessory set to monitor the air flow is available for this purpose, see page 61 (8.2 Air flow detector set).

7.11 Purge air and cooling air

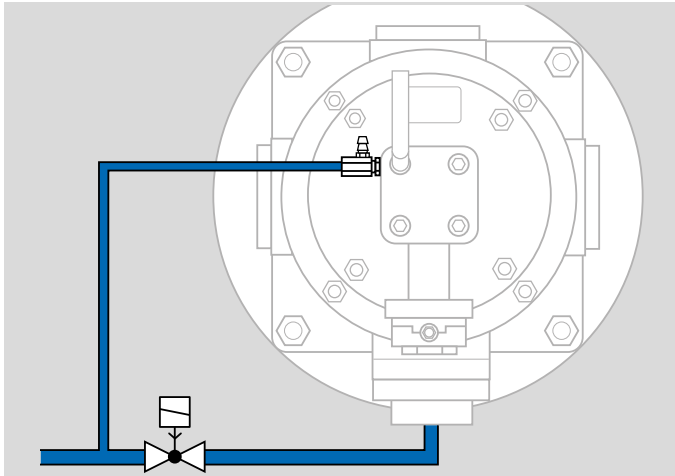

The purge air must be connected to the burner ECOMAX in order to ensure safe ignition and monitoring, and in order to avoid problems caused by condensation and/or overheating.

The required purge air volume is approx. 0.5 to 1.0% of the air volume for rated capacity, but subject to a minimum of 1 m³_(st)/h.

The purge air is connected to the gas connection flange next to the electrode or, with UV control, to the purge air connection of the UV sensor. The purge air is tapped upstream of the air control valve so that the purge air continues to flow even if the burner is switched off.

To limit the volume of purge air, special nozzles can be used which are adjusted to the required air supply pressure for the ECOMAX – see page 62 (8.5 Purge air/cooling air nozzles).

Burner	Nozzle for electrode purge	Purge air nozzle on UV sensor
ECOMAX 0	Nozzle electrode ECO 0 Rp 1/4 D=2.5 /E	Nozzle UV ECO 0–3 Rp 1/4 D=2.5 /B
ECOMAX 1–3	Nozzle electrode ECO 1–3 Rp 1/4 D=2.5 /E	Nozzle UV ECO 0–3 Rp 1/4 D=2.5 /B
ECOMAX 4–6	Nozzle electrode ECO 4–6 Rp 1/4 D=4.0 /E	Nozzle UV ECO 4–6 Rp 1/4 D=4.0 /B

In very high furnace chamber temperatures, we recommend that the burner head is cooled by selecting a larger nozzle or a supply line of D = 8 mm without a nozzle.

7.12 Condition on delivery

The gas and air connection and the flue gas connection can be aligned to suit the order based on the intended installation on the furnace. The positions of the connections are coded with numbers 0, 3, 6 and 9.

Identifier	Position of the connections
0	top
3	right-hand side
6	bottom
9	left-hand side

The identifiers for the positions of the connections are stated in the sequence flue gas – air – gas.

If there is no specification, the burners are supplied as follows:

ECOMAX../R for radiant tube heating with a connector position 066, in other words with the flue gas connection at the top and the gas and air connection at the bottom.

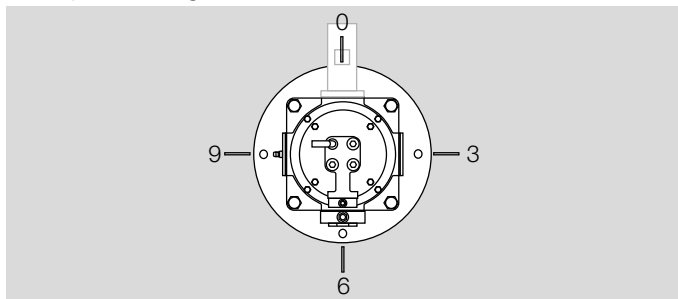

Add-on components with the designation /E, such as the air flow detector set, UV adapter, purge air nozzle, etc., are installed on the burner at the factory as long as they are ordered at the same time as the burner.

7.13 Increased furnace cooling with ECOMAX..K

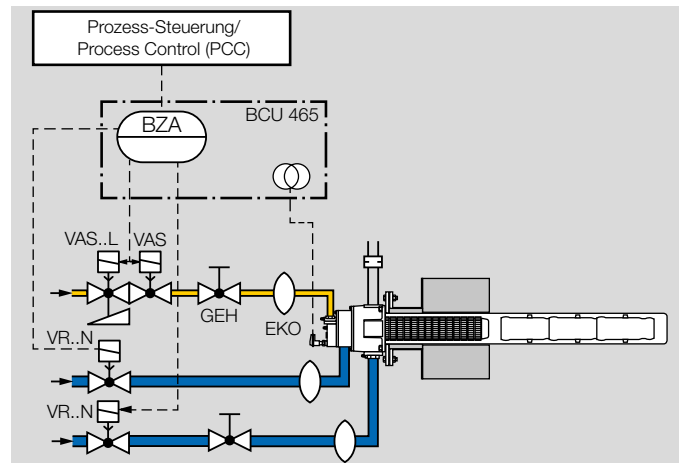

Depending on the process requirements, a two-level cooling system can be implemented.

The “normal” cooling system is activated by actuating the air valve for the burner. An additional cooling air valve can be activated using terminals 85/86/87 on the BCU. The additional cooling air valve is actuated separately by the process control system (see [TI BCU 4](#)).

If the BCU is in standby, the additional cooling air valve is activated together with the combustion air valve by the external air valve control.

7.14 Emissions

The CO and NO_x values depend on the furnace chamber temperature, air preheating, burner type and burner settings (NO_x values available on request).

If operated with LPG, the NO_x values are approx. 25% higher.

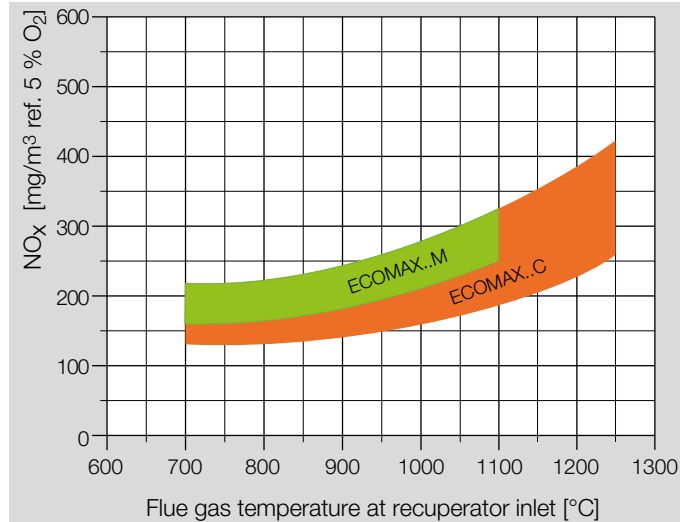

NO_x values in the diagram apply to natural gas

The CO emissions depend on the burner operating mode and flue gas temperature at the recuperator inlet:

- for continuous operation with a flue gas temperature of around 600°C or over upstream of the recuperator below 10 ppm
- for intermittent operation with a flue gas temperature of around 750°C or over upstream of the recuperator below 10 ppm

7.15 Build up of noise

When the burner is installed, the sound pressure level of the individual burner which can be measured outside the furnace is generally between 75 and 82 dB(A).

The measurable value on a furnace system depends on the capacity, excess air, flue gas extraction and flue gas temperature of the individual burners and on the burner layout and ambient influences (Sound pressure level on request).

8 Accessories

8.1 Air connection set

Specially machined barrel nipples which ensure a reliable, correct measurement at the orifices installed in the burner. The /E version is installed when the burner is supplied.

Designation	Order No.
Air inlet pipe ECO 0-1 R 1 /E	22802897
Air inlet pipe ECO 2 R 1 1/2 /E	22802898
Air inlet pipe ECO 3-5 R 2 /E	22802899
Air inlet pipe ECO 6 R 3 /E	22802900

8.2 Air flow detector set

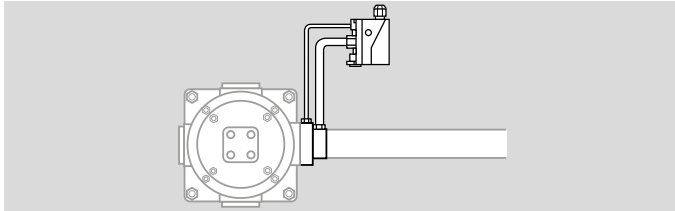

The differential pressure switch to monitor the air flow is used for the automatic monitoring of the air flow on the burner ECOMAX in conjunction with the burner control unit BCU 465. The differential pressure switch monitors the air flow during pre-purge and burner operation. If there is no air pressure, the burner is switched off or the burner is not enabled. The pressure switch switching point should be set to approx. 80% of the differential pressure in normal operation.

Designation	Order No.
Air flow detector set ECO /E	21802994

8.3 VAH connection set

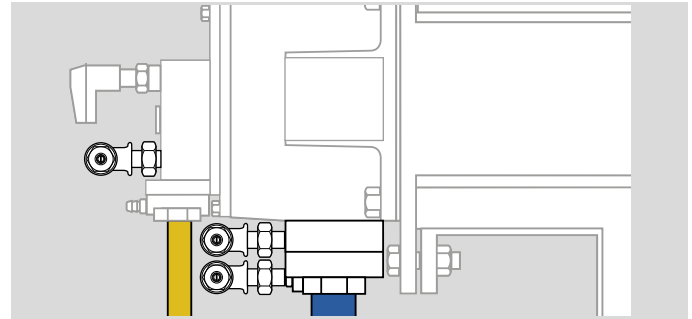

The VAH connection set also comprises the connection for the gas control line p_{d-} , which is connected downstream of the gas orifice integrated in the burner so that a gas supply pressure of 80 mbar is sufficient in the supply line (100 mbar is recommended).

Designation	Order No.
Connection-set VAH ECO /E	21802993

8.4 UV adapter set

An adapter is required to install the UVS 10.

Designation	Order No.
Adapter-Set ECO 1-5-UVS 10 /E	21800791

8.5 Purge air/cooling air nozzles



Nozzle to limit the volume of purge air in order to achieve safe monitoring of the ECOMAX burner and to avoid condensation and overheating.

Nozzle for electrode purge

Burner	Designation of nozzle	Order No.
ECOMAX 0	Nozzle electrode ECO 0 Rp 1/4 D = 2.5 /E	21802944
ECOMAX 1–3	Nozzle electrode ECO 1–3 Rp 1/4 D = 2.5 /E	21802945
ECOMAX 4–6	Rp 1/4 D = 4.0 /E	21802946

» In the case of ECOMAX menox burners, the $d = 2.5$ mm nozzle for electrode purge is included in the scope of delivery of the burner.

UV sensor purge air nozzle

Burner	Designation of nozzle	Order No.
ECOMAX 0–3	Nozzle UV ECO 0–3 Rp 1/4 D = 2.5 /B	21802989
ECOMAX 4–6	Nozzle UV ECO 4–6 Rp 1/4 D = 4.0 /B	21802990

» The UV sensor purge air nozzle with $d = 2.5$ mm (21802989) is adequate for ECOMAX menox burners.

To connect the purge air to the electrode or UV sensor:

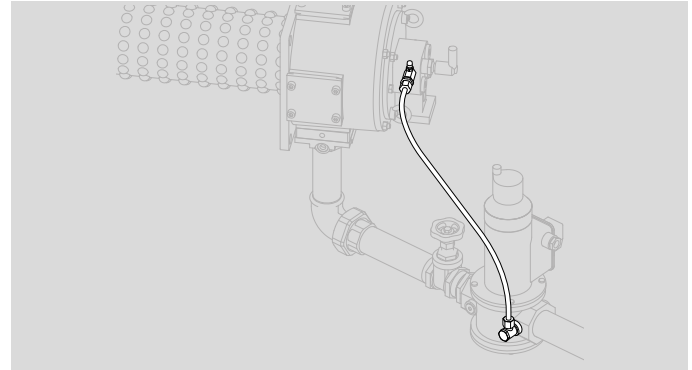

Length	Designation	Order No.
1 m	Purge Air-Set 1/4-8/6 ECO PTFE-1M	21803332
2 m	Purge Air-Set 1/4-8/6 ECO PTFE-2M	21803645

8.6 Flue gas guide tube FGT set..D

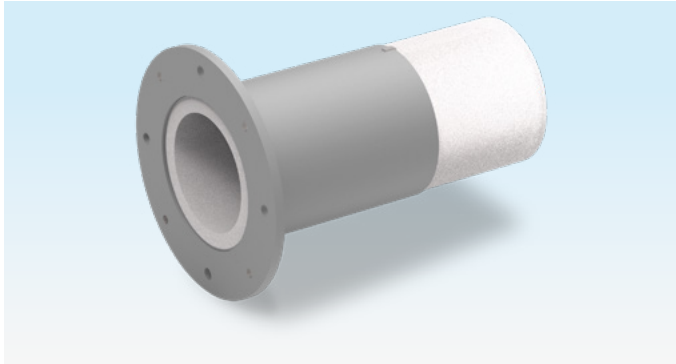

ECOMAX..C

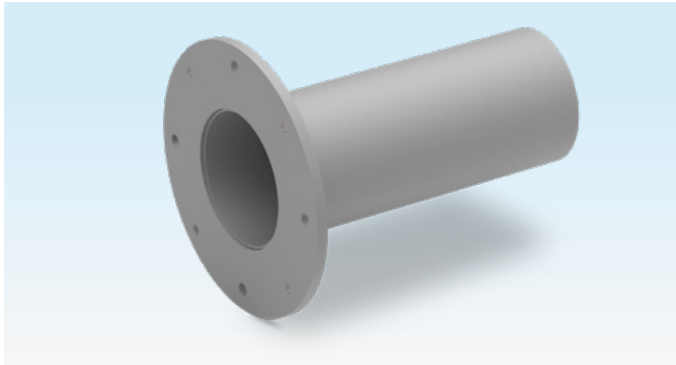

ECOMAX..M

When using the ECOMAX burners for direct heating, a flue gas guide tube FGT set..D is required.

The FGT set..D is available in lengths in various increments, which are suited to different burner lengths.

There is a version for furnace chamber temperatures up to 1250°C for ECOMAX..C (including shaped part made of vacuum-formed ceramic fibres (RCF)).

Scope of delivery: flue gas guide tube FGT with burner gasket, mounting gasket, as well as 4 threaded bolts, washers and nuts for attaching it to the burner.

ECOMAX..C

Flue gas guide tube	Order No.
FGT SET ECO 1C545/D-HT	21800926
FGT SET ECO 2C545/D-HT	21800928
FGT SET ECO 3C545/D-HT	21800930
FGT SET ECO 4C545/D-HT	21800629
FGT SET ECO 5C545/D-HT	21801325

ECOMAX..M

Flue gas guide tube	Order No.
FGT SET ECO 1M545/D	21800195
FGT SET ECO 2M545/D	21800177
FGT SET ECO 3M545/D	21800694
FGT SET ECO 4M545/D	21800162
FGT SET ECO 5M545/D	21800499
FGT SET ECO 6M545/D	21800660

8.7 Flue gas eductor EJEK



For direct heating

The eductor EJEK generates a negative pressure with a centrally positioned nozzle and thus draws the flue gases out of the furnace chamber through the burner's heat exchanger.

Designation for ECOMAX..C	Order No.
EJEK 1-K269-M625-H-AGK-HT-S	22800872
EJEK 2-K285-M540-H-AGK-HT-A-S	22802953
EJEK 3-K292-M620-AGK-HT-A-S	22801413
EJEK 4-K345-M920-AGK-HT-A-S	22801701
EJEK 5-K345-M1165-AGK-HT-A-S	22801828

Special version available on request

Designation for ECOMAX..M	Order No.
EJEK 1-K269-M625-H-AGK-S	22800931
EJEK 2-K285-M540-H-AGK-A-S	22802952
EJEK 3-K292-M620-AGK-A-S	22801159
EJEK 4-K345-M920-AGK-A-S	22801700
EJEK 5-K345-M1165-AGK-A-S	22801826
EJEK 6-K530-M1618-AGK-A-S	22801903

8.8 Flue gas connector FLUP

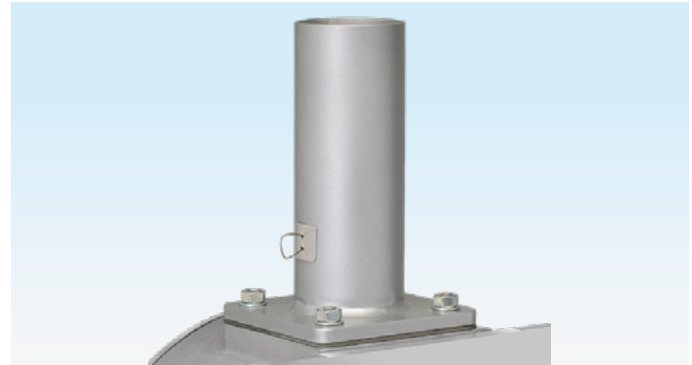

For indirect heating

For indirect heating, the flue gas connector FLUP discharges the flue gases into the site flue gas system on the furnace.

Designation	Order No.
FLUP 0-32D-M230-C-B-S	21801830
FLUP 1/2-50D-M331-C-S	21100612
FLUP 3-65D-M353-C-S	21102259
FLUP 4/5-100D-M399-C-S	21102718

Special version available on request

8.9 Ceramic radiant tube SER-C

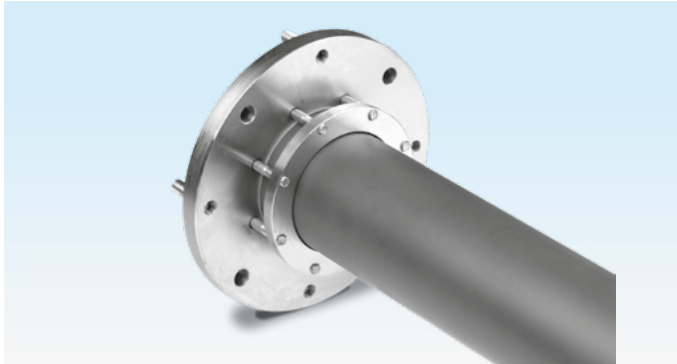

For heat treatment processes in which combustion gases must be kept separate from the product. The patented flange connection is air-tight.

Material: SiSiC, max. application temperature: 1300°C (2372°F).

Further information can be found in the Technical Information bulletin Ceramic radiant tube SER-C.

Order No. on request.

8.10 Segmented flame tube SICAFLEX®



Segmented ceramic flame tubes SICAFLEX to guide hot flue gases in radiant tubes SER-C and SER-M.

For further information, see [Technical Information Segmented flame tube SICAFLEX](#).

Order No. on request.

8.11 Cruciform spacer



Refractory clay (for horizontal firing only)

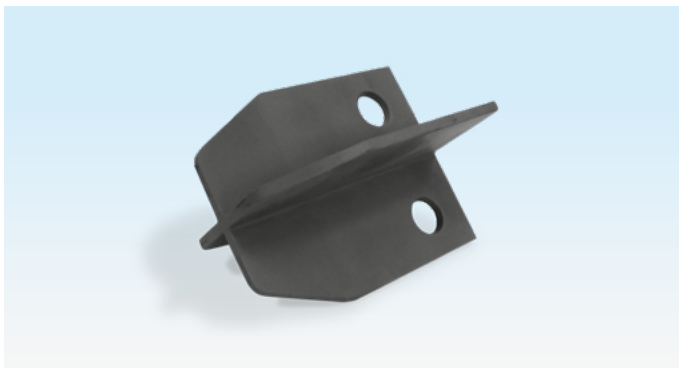

SiSiC

ECOMAX

For installation of the SICAFLEX segmented flame tube in vertical radiant tubes, see [TI SICAFLEX – SICAFLEX in vertically fitted single ended radiant tubes](#).

ECOMAX LE

SiSiC cruciform spacer required for horizontally and vertically fitted single ended radiant tubes.

The cruciform spacer ensures optimum sizing of the recirculation gap between the segmented flame tube and the burner.

Available on request in different sizes depending on the SICAFLEX sizes and different heights.

8.12 Flue gas guide tube FGT set

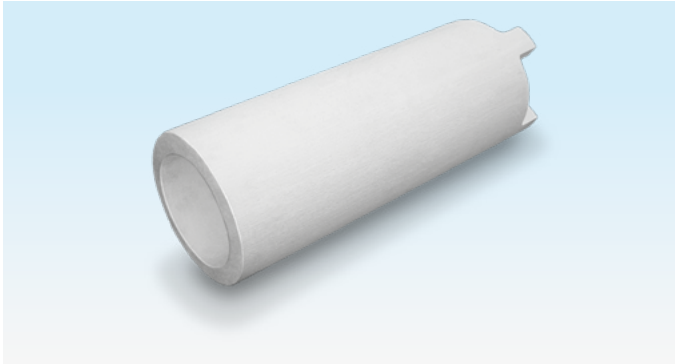

To guide the flue gases if smaller burners are used than those normally intended, see page 49 (7.2 Radiant tubes). The flue gas guide tube ensures sufficient heat exchange via the burner recuperator.

Material: shaped part made of vacuum-formed ceramic fibres (RCF).

Available in different sizes and versions suitable for the SER-C radiant tube and ECOMAX burner sizes.

*Further FGT sets are available on request.
FGT sets for ECOMAX LE on request.*

8.13 Pipework

As an option, the burners can be supplied with ready-installed pipework for gas and air.

Designation	Order No.
FGT-SET ECO 0C395-SER-C 142	22802270
FGT-SET ECO 0C475-SER-C 142	22104810
FGT-SET ECO 0C556-SER-C 142	22105204
FGT-SET ECO 0C636-SER-C 142	22106581
FGT-SET ECO 0C395-SER-C 162	22104287
FGT-SET ECO 0C556-SER-C 162	22105968
FGT-SET ECO 1C545-SER-C 162	22102113
FGT-SET ECO 1C593-SER-C 162	22105298
FGT-SET ECO 1C545-SER-C 202	22803158
FGT-SET ECO 1C593-SER-C 202	22801083
FGT-SET ECO 2C545-SER-C 202	22803949

8.13.1 Direct heating

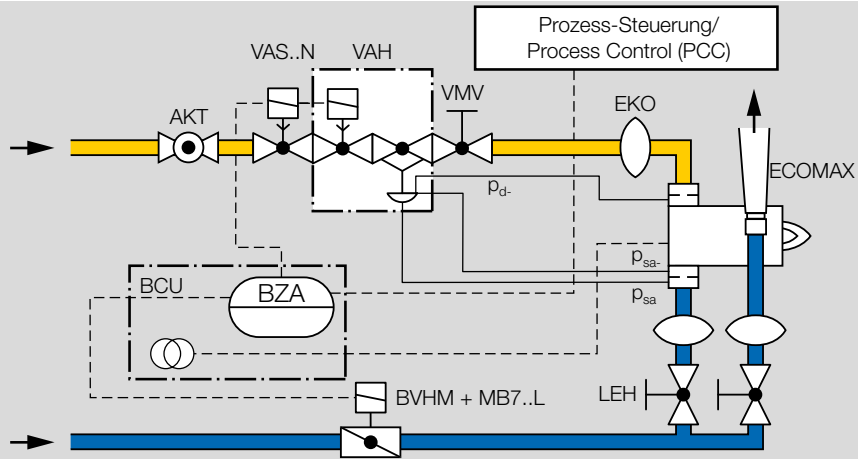

Example

	ECOMAX	Material No.	Designation	Combinations
Gas	0-3	86594777	GVR5 15R05-15R05-W-ECO 0-3	VAS..N + VAH + VMV
Gas	4	86594778	GVR5 20R05-20R05-W-ECO 4	VAS..N + VAH + VMV
Gas	5	86494779	GVR5 25R05-25R05-W-ECO 5	VAS..N + VAH + VMV
Air	0	86594782	L 40R-25R-32R-W-ECO 0-EJEK	VAA..L + LEH + CIM
Air	1	86594783	L 50R-25R-32R-W-ECO 1-EJEK	VAA..L + LEH + CIM
Air	2	86594784	L 65R-40R-40R-W-ECO 2-EJEK	BVHM, MB 7LW6 + LEH + LEH
Air	3	86594785	L 65R-50R-50R-W-ECO 3-EJEK	BVHM, MB 7LW6 + LEH + LEH
Air	4	86594786	L 80F-50R-65R-W-ECO 4-EJEK	BVHM, MB 7LW6 + LEH + CIM
Air	5	86594787	L 80F-50R-65R-W-ECO 5-EJEK	BVHM, MB 7LW6 + LEH + CIM

8.13.2 Radiant tube heating

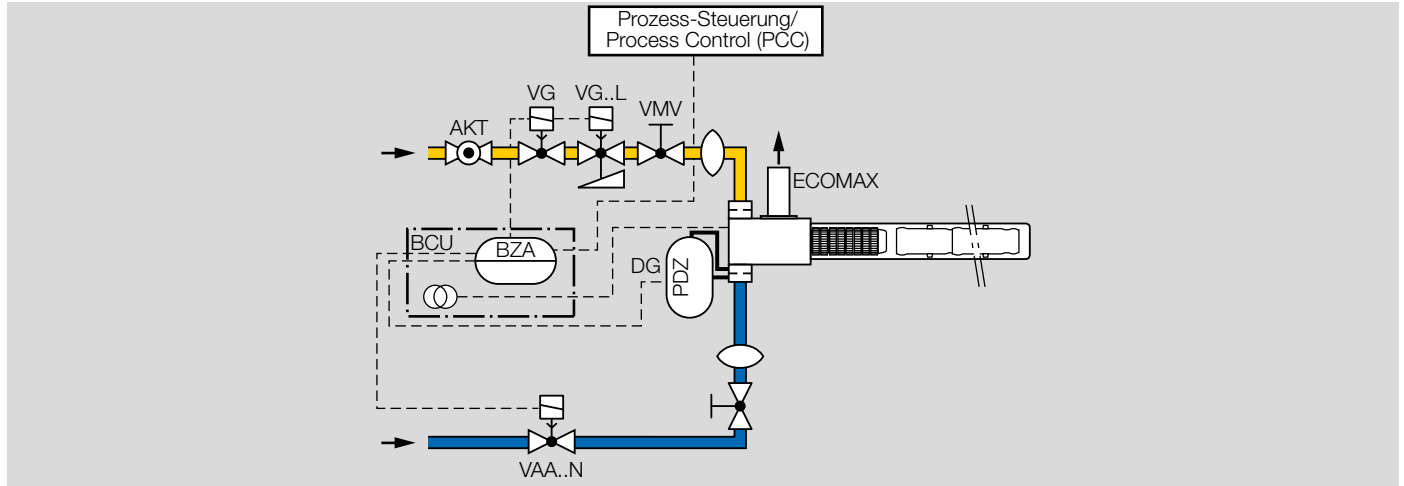

Example

	ECOMAX	Material No.	Designation	Combinations
Gas	0-3	86594195	GS 15R02-15R02-W-ECO 0-3	VG..N + VG..L + GEH
Gas	4	86594654	GS 20R05-20R05-W-ECO 4	VCS 1 (VAS..N+VAS..L) + VMV
Gas	5	86594687	GS 25R05-25R05-W-ECO 5	VCS 1 (VAS..N+VAS..L) + VMV
Air	0-1	86594689	L 25R-25R-W-ECO 0-1	VAA..N + LEH
Air	2	86594693	L 40R-40R-W-ECO 2	VAA..N + LEH
Air	3	86594694	L 50R-50R-W-ECO 3	VAA..N + LEH
Air	4	86594696	L 65R-50R-W-ECO 4	BVHM + LEH
Air	5	86594697	L 65R-50R-W-ECO 5	BVHM + CIM

9 Technical data

Gas supply pressure and air supply pressure each depend on the type of use and gas type.

Direct heating:

gas supply pressure, see page 40 (6.8.2 Gas pressure),

air supply pressure, see page 43 (6.9.2 Air pressure).

Radiant tube heating:

gas supply pressure, see page 55 (7.8.2 Gas pressure),

air supply pressure, see page 57 (7.9.2 Air pressure).

(Pressure differentials for gas and air: see burner diagrams at www.docuthek.com – registration required)

Heating: direct with eductor or indirect in radiant tube.

Control type: On/Off.

Adjusting range: 60% to 100%.

Flame velocity: approx. 130 to 170 m/s.

Flame control: direct ionization control (UV control as an option).

Ignition: direct spark ignition.

Burner	Recuperator	Max. flue gas temperature at recuperator inlet
ECOMAX..C	Ceramic (SiSiC)	1250°C*
ECOMAX..M	Cast steel	1150°C
ECOMAX..F	Metallic	1050°C

* We advise against using this in forging and heating furnaces in which raw material is heated.

The visible flame diameter is 0.3–0.5 times the burner diameter ØB for natural gas operation in the open air and max. connection rating and air index 1.15.

Burner	Capacity [kW]	Flame length [mm]*
ECOMAX 0	25	300

Burner	Capacity [kW]	Flame length [mm]*
ECOMAX 1	36	300
ECOMAX 2	60	400
ECOMAX 3	100	450
ECOMAX 4	180	800
ECOMAX 5	250	800
ECOMAX 6	500	1000

* Visible range for natural gas operation in the open air, max. connection rating and air index 1.15.

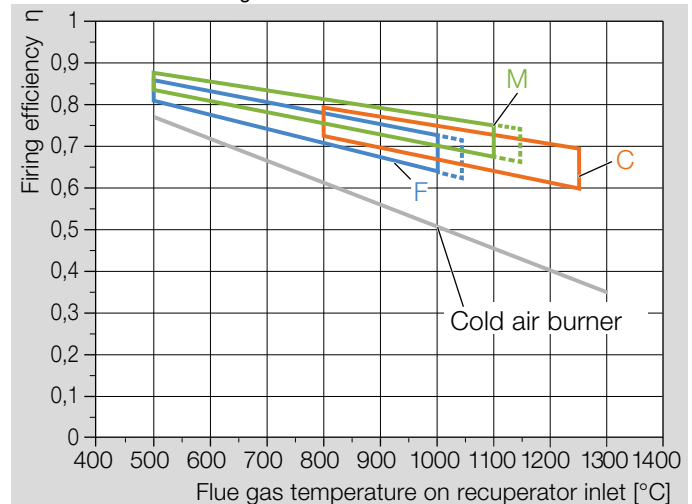

REACH Regulation

Information pursuant to REACH Regulation No. 1907/2006, Article 33.

Insulation FGT-Set contains refractory ceramic fibres (RCF)/aluminium silicate wool (ASW).

RCF/ASW are listed in the Candidate List of the European REACH Regulation No. 1907/2006.

9.1 Dimensions

9.1.1 ECOMAX..C direct heating

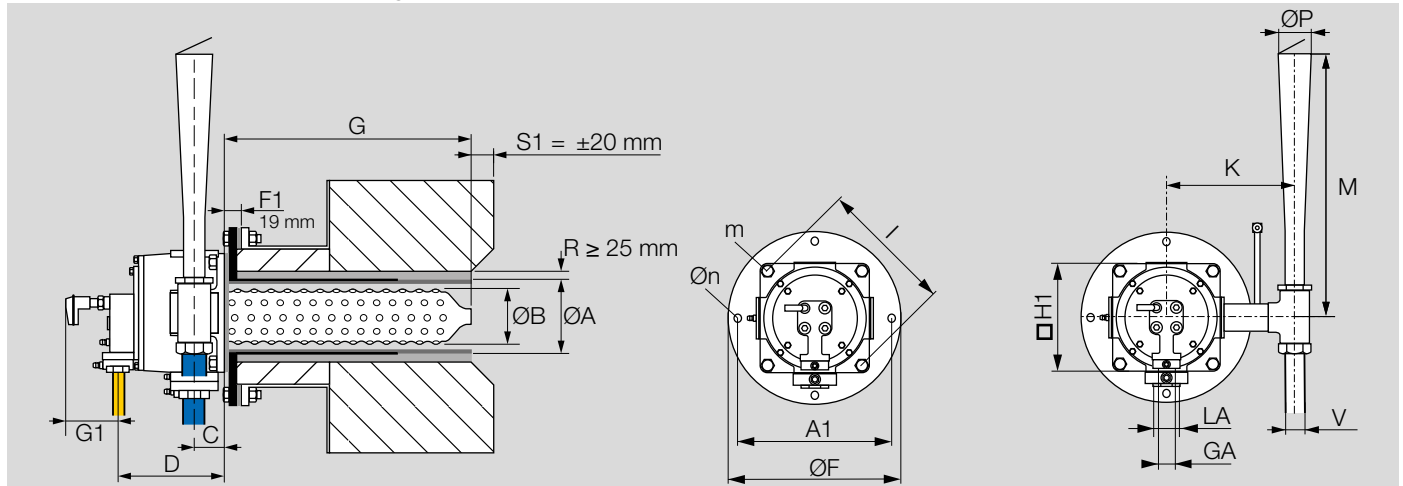

Type	ECOMAX								FGT set					EJEK				Weight kg ³⁾	
	GA	LA	ØB	C ¹⁾	D ¹⁾	G1	G	H1	ØA ²⁾	ØF	A1	Øn	l	m	V	K	M		ØP
mm								mm					mm						
ECOMAX 0C	R ½	Rp 1	86	60	179	~78	395, 475, 556, 636	182	142	300	260	4 x 18	210	4 x M12	R ¼	269	625	43	~11
ECOMAX 1C	R ½	Rp 1	123	60	212	~80	545, 593, 641, 689	236	180	330	280	4 x 19	290	4 x M16	R ¼	269	625	43	~19
ECOMAX 2C	R ½	Rp 1½	142	60	212	~80	545, 613, 681	236	200	330	280	4 x 19	290	4 x M16	R ½	285	540	83	~21
ECOMAX 3C	R ½	Rp 2	178	83	262	~80	545, 617, 689	280	236	385	325	4 x 19	330	4 x M16	R 2	292	620	98	~33
ECOMAX 4C	R ¾	Rp 2	240	95	298	~86	545, 595, 645, 695	368	300	480	420	4 x 19	445	4 x M16	R 2½	345	920	128	~48
ECOMAX 5C	R 1	Rp 2	273	95	298	~86	545, 595, 645, 695	368	336	480	420	4 x 19	445	4 x M16	G 2½	345	1165	153	~55

1) Without gasket (d = 1.3 mm).

2) Diameter without metal holder (with metal holder: ØA + approx. 3 mm).

3) Weight of the shortest length burner.

9.1.2 ECOMAX..M direct heating

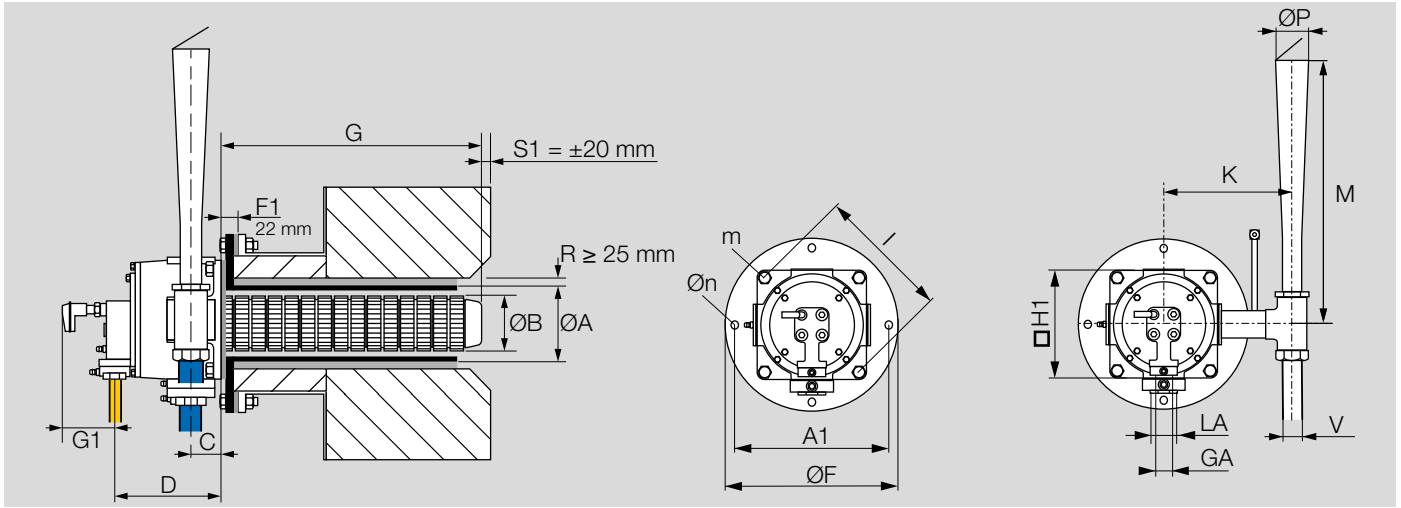

Type	ECOMAX								FGT set					EJEK				Weight kg ²⁾			
	GA	LA	ØB	C ¹⁾	D ¹⁾	G1	G	H1	ØA	ØF	A1	Øn	l	m	V	K	M		ØP		
																		mm	mm	mm	mm
ECOMAX 1M	R ½	Rp 1	123	60	212	~78	545, 595, 645, 695	236	133	330	280	4x19	290	4xM16	R ¼	269	625	43	~35		
ECOMAX 2M	R ½	Rp 1½	142	60	212	~80	545, 595, 645, 695	236	156	330	280	4x19	290	4xM16	R ½	285	540	83	~41		
ECOMAX 3M	R ½	Rp 2	178	83	262	~80	545, 595, 645, 695	280	193	385	325	4x19	330	4xM16	R 2	292	620	98	~53		
ECOMAX 4M	R ¾	Rp 2	240	95	298	~86	545, 595, 645, 695	368	254	480	420	4x19	445	4xM16	R 2½	345	920	128	~90		
ECOMAX 5M	R 1	Rp 2	273	95	298	~86	545, 595, 645, 695	368	287	480	420	4x19	445	4xM16	G 2½	345	1165	153	~91		

1) Without seal (d = 4 mm).

2) Weight of the shortest length burner.

9.1.3 ECOMAX..F direct heating

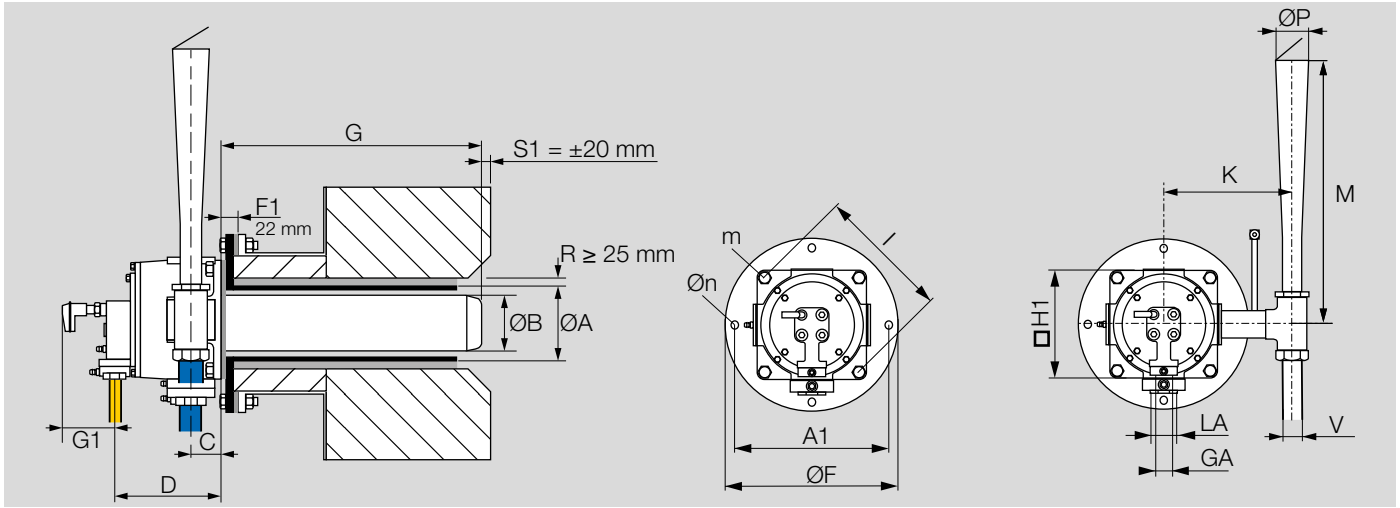

Type	ECOMAX								FGT set					EJEK				Weight kg ²⁾				
	GA	LA	ØB	C ¹⁾	D ¹⁾	G1	G	H1	ØA	ØF	A1	Øn	l	m	V	K	M		ØP			
																			mm	mm	mm	mm
ECOMAX 1F	R ½	Rp 1	109	60	212	~78	545, 595, 645, 695	236	133	330	280	4x19	290	4xM16	R ¼	269	625	43	~27			
ECOMAX 2F	R ½	Rp 1½	128	60	212	~80	545, 595, 645, 695	236	156	330	280	4x19	290	4xM16	R ½	285	540	83	~31			
ECOMAX 3F	R ½	Rp 2	164	83	262	~80	545, 595, 645, 695	280	193	385	325	4x19	330	4xM16	R 2	292	620	98	~47			
ECOMAX 4F	R ¾	Rp 2	216	95	298	~86	545, 595, 645, 695	368	254	480	420	4x19	445	4xM16	R 2½	345	920	128	~75			
ECOMAX 5F	R 1	Rp 2	224	95	298	~86	545, 595, 645, 695	368	287	480	420	4x19	445	4xM16	G 2½	345	1165	153	~76			

1) Without seal (d = 4 mm).

2) Weight of the shortest length burner.

9.1.4 ECOMAX..C radiant tube heating

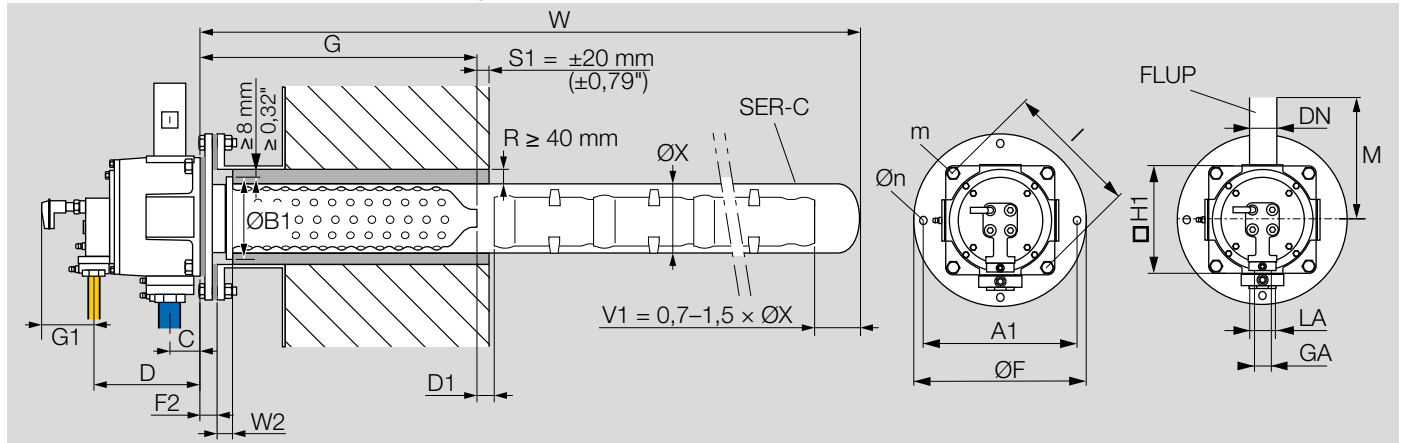

Type	ECOMAX										SER-C							FLUP		Weight kg ³⁾	
	GA	LA	C ¹⁾	D ¹⁾	G1	G	H1	F2 ²⁾	D1	W2	B1	ØX	W	ØF	A1	Øn	l	m	DN		M
ECOMAX 0C	R ½	Rp 1	60	179	~78	395, 475, 556, 636	182	~34	30	35	160	100	1000–2600	290	240	4 x 14	210	4 x M12	32	230	~11
ECOMAX 1C	R ½	Rp 1	60	212	~80	545, 593, 641, 689	236	~37	30	50	200	142	1500–2600	330	280	4 x 19	290	4 x M16	50	331	~19
ECOMAX 2C	R ½	Rp 1½	60	212	~80	545, 613, 681	236	~37	30	50	220	162	1500–3000	330	280	4 x 19	290	4 x M16	50	331	~21
ECOMAX 3C	R ½	Rp 2	83	262	~80	545, 617, 689	280	~37	30	50	260	202	1500–3000	385	325	4 x 19	330	4 x M16	65	353	~33

1) Without gasket (d = 1.3 mm).

2) F2 = burner gasket + SER-C radiant tube flange + SER-C radiant tube gasket

3) Weight of the shortest length burner.

9.1.5 ECOMAX..M radiant tube heating

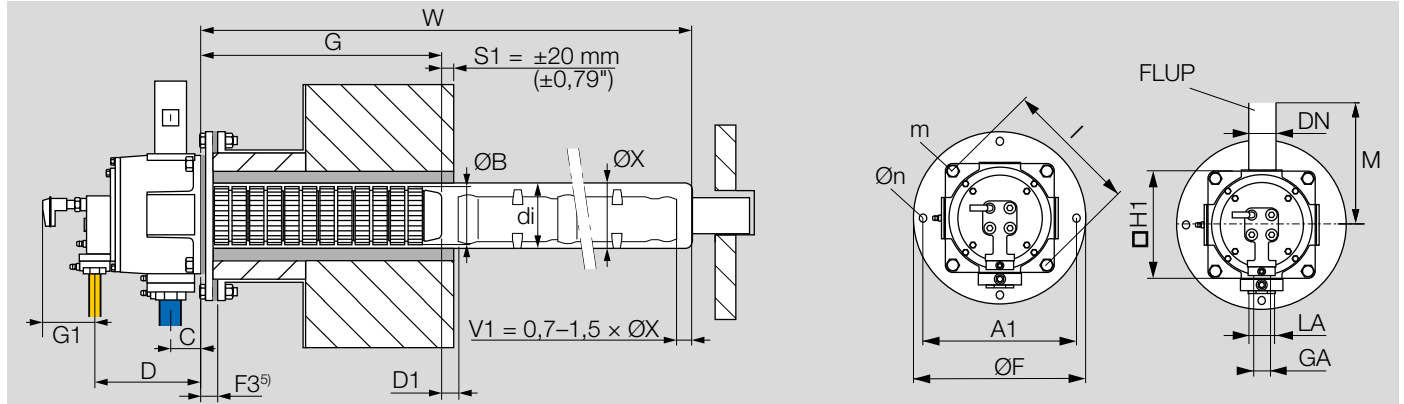

Type	ECOMAX								SER-M						FLUP		Weight kg ⁴⁾		
	GA	LA	ØB	C ¹⁾	D ¹⁾	G1	G	H1	D1	di	ØX ²⁾	ØF ³⁾	A1 ³⁾	Øn ³⁾	l	m		DN	M
mm																			
ECOMAX 1M	R ½	Rp 1	123	60	212	~78	545, 595, 645, 695	236	30	> 128	di + 2s	330	280	4 x 19	290	4 x M16	50	331	~35
ECOMAX 2M	R ½	Rp 1½	142	60	212	~80	545, 595, 645, 695	236	30	> 147	di + 2s	330	280	4 x 19	290	4 x M16	50	331	~41
ECOMAX 3M	R ½	Rp 2	178	83	262	~80	545, 595, 645, 695	280	30	> 185	di + 2s	385	325	4 x 19	330	4 x M16	65	353	~53
ECOMAX 4M	R ¾	Rp 2	240	95	298	~86	545, 595, 645, 695	368	50	> 248	di + 2s	480	420	4 x 19	445	4 x M16	100	399	~90
ECOMAX 5M	R 1	Rp 2	273	95	298	~86	545, 695	368	50	> 280	di + 2s	480	420	4 x 19	445	4 x M16	100	399	~91

1) Without gasket (d = 4 mm).

2) s = Wall thickness of radiant tube.

3) On site, the details are suggestions.

4) Weight of the shortest length burner.

5) F3 = burner gasket + SER-M radiant tube flange + SER-M radiant tube gasket (radiant tube flange and gasket to be provided by the customer)

9.1.6 ECOMAX..F radiant tube heating

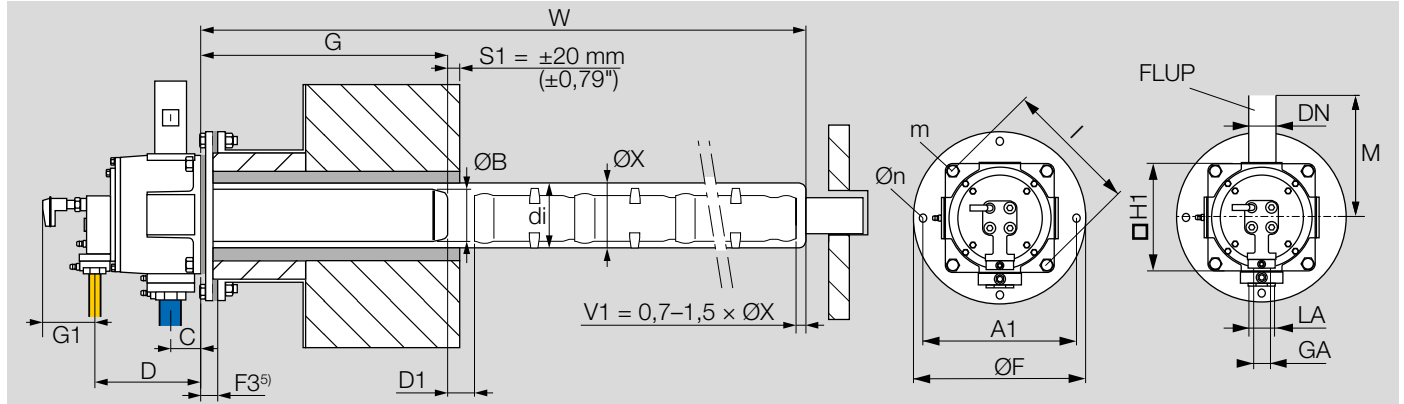

Type	ECOMAX							SER-M							FLUP		Weight kg ⁴⁾		
	GA	LA	ØB	C ¹⁾	D ¹⁾	G1	G	H1	D1	di	ØX ²⁾	ØF ³⁾	A1 ³⁾	Øn ³⁾	l	m		DN	M
mm																			
ECOMAX 1F	R ½	Rp 1	109	60	212	~78	545, 595, 645, 695	236	30	> 128	di + 2s	330	280	4 x 19	290	4 x M16	50	331	~35
ECOMAX 2F	R ½	Rp 1½	128	60	212	~80	545, 595, 645, 695	236	30	> 147	di + 2s	330	280	4 x 19	290	4 x M16	50	331	~41
ECOMAX 3F	R ½	Rp 2	164	83	262	~80	545, 595, 645, 695	280	30	> 185	di + 2s	385	325	4 x 19	330	4 x M16	65	353	~53
ECOMAX 4F	R ¾	Rp 2	216	95	298	~86	545, 595, 645, 695	368	50	> 248	di + 2s	480	420	4 x 19	445	4 x M16	100	399	~90
ECOMAX 5F	R 1	Rp 2	224	95	298	~86	545, 595, 645, 695	368	50	> 280	di + 2s	480	420	4 x 19	445	4 x M16	100	399	~91

1) Without gasket (d = 4 mm).

2) s = Wall thickness of radiant tube.

3) On site, the details are suggestions.

4) Weight of the shortest length burner.

5) F3 = burner gasket + SER-M radiant tube flange + SER-M radiant tube gasket (radiant tube flange and gasket to be provided by the customer)

10 Maintenance cycles

Twice per year, but if the media are highly contaminated, this interval should be reduced.

For more information

The Honeywell Thermal Solutions family of products includes Honeywell Combustion Safety, Eclipse, Exothermics, Hauck, Kromschroder and Maxon. To learn more about our products, visit ThermalSolutions.honeywell.com or contact your Honeywell Sales Engineer.

Elster GmbH
Strotheweg 1, D-49504 Lotte
T +49 541 1214-0
hts.lotte@honeywell.com
www.kromschroeder.com

© 2024 Elster GmbH

We reserve the right to make technical modifications in the interests of progress.

