

Gas pressure sensors DGS

TECHNICAL INFORMATION

- Digital connection facilities for smart gas sections
- Pressure gauge and pressure transmitter in a single device
- Minimum installation effort
- Predictive maintenance
- Analyses for trends/system optimization
- Local and remote monitoring (Thermal IQ™)
- Suitable for hydrogen



Contents

Contents	2	6.2.5 MIN reset	13
1 Application	4	6.2.6 MAX delay time	13
2 Application examples	5	6.2.7 MIN delay time	13
2.1 Air line with MIN, MAX pressure monitoring	5	6.2.8 Overpressure value	13
2.2 Low and high gas pressure protection at the gas inlet section	5	6.2.9 Zero adjustment	13
3 Certification	6	6.2.10 Output settings	14
3.1 Certificate download	6	6.2.11 Filter time	14
3.2 Declaration of conformity	6	6.3 Non-safety parameters	15
3.3 IEC	6	6.3.1 MAX warning	16
3.4 SIL	6	6.3.2 MAX alarm	16
3.5 REACH Regulation	7	6.3.3 MIN warning	16
3.6 China RoHS	7	6.3.4 MIN alarm	16
4 Function	8	6.3.5 Communication	16
4.1 Transmitter-, MIN-/MAX function	8	6.4 Settings	17
4.2 Relative pressure (positive pressure)	8	6.4.1 Measuring unit	18
4.3 Differential pressure	8	6.4.2 Temperature unit	18
4.4 Part designations	9	6.4.3 Decimal Separator	18
4.5 Electrical connection	9	6.4.4 Brightness	18
4.5.1 Voltage supply and 4–20 mA signal	9	6.4.5 Language	18
4.5.2 Communication interface (Fast Ethernet)	9	6.4.6 Password	18
4.6 LED (colour/flash code)	10	6.5 Statistics	19
5 Selection	11	6.5.1 Event history	19
5.1 Selection table	11	6.5.2 Device statistics	20
5.1.1 Connections	11	6.5.3 Customer statistics	20
6 Parameter	12	6.5.4 Clear event history	20
6.1 General	12	6.5.5 Clear customer statistics	20
6.2 Safety parameters	12	6.6 Information	21
6.2.1 Sensor function	13	6.6.1 Device name	21
6.2.2 MAX switching value	13	6.6.2 Firmware	21
6.2.3 MIN switching value	13	6.6.3 Network	21
6.2.4 MAX reset	13	6.7 Service	21
		6.7.1 Firmware	21
		7 Web server	22
		8 Modbus TCP	24
		8.1 Modbus holding registers	24
		8.1.1 Process data	24
		8.1.2 Event history	25

8.1.3 Device statistics	26	15.3 Communications protocols	43
8.1.4 Customer statistics	27	15.3.1 Communications protocols	43
8.1.5 Settings	27	15.3.2 HTTPS (Hypertext Transfer Protocol Secure)	43
8.1.6 Safety parameters	28	15.4 Reporting vulnerabilities	43
8.1.7 Non-safety parameters	28	16 Open source software licences	44
8.1.8 Hardware parameters	28	17 Safety-specific characteristic values for SIL	45
8.1.9 Bus parameters	29	17.1 Designed lifetime	45
9 Output signal coding	30	18 Safety information in accordance with EN 61508-2	46
10 Project planning information	31	18.1 General	46
10.1 Installation	31	18.2 Interfaces	47
10.1.1 Installation position	31	18.3 Communication	48
10.2 MIN and MAX switching point range	31	18.4 SIL	49
10.3 Hydrogen	31	19 Glossary	50
11 Accessories	32	19.1 Regulating and control functions	50
11.1 Test key PIA	32	19.2 NAMUR	50
11.2 Tube set	32	19.3 Diagnostic coverage DC	50
11.3 Fastening set with screws, U-shape bracket	32	19.4 Mode of operation	50
11.4 Connecting set for DGS and DG	33	19.5 Probability of dangerous failure PFH _D	50
12 Technical data	34	19.6 Mean time to dangerous failure MTTF _d	50
12.1 Ambient conditions	34	19.7 Safe failure fraction SFF	50
12.2 Mechanical data	34	For more information	51
12.3 Electrical data	34		
12.4 Measuring range	35		
12.4.1 Overall accuracy to EN 1854:2022+A1:2023	35		
12.5 Safety instructions	36		
12.6 Dimensions	36		
13 Converting units	37		
14 Maintenance cycles	38		
15 Cyber and IT security	39		
15.1 Physical device protection	39		
15.2 Securing the network	40		
15.2.1 Physical separation	40		
15.2.2 Firewall isolation	41		
15.2.3 Network address translation (NAT)	42		

1 Application

The pressure sensor DG smart is a relative and differential pressure sensor which monitors the MIN/MAX and/or differential pressure for gas, air, flue gas or other non-aggressive gases. For further information, see page 34 (12.2 Mechanical data) and page 11 (5.1 Selection table).

DG smart meets the current requirements of EN 1854:2022+A1:2023 (Class A and C, see page 50 (19.1 Regulating and control functions)) and international standards which require the safety function of MAX/MIN monitoring and shut-down.

As a measuring transducer and pressure transmitter, the sensor supplies precise, reliable measurements and can be used for low-pressure combustion air and fuel gas applications which require precise, accurate pressure monitoring.



HMI interface and LED display

The pressure measurements can be supplied to monitoring systems in real time using a Modbus TCP bus protocol and a 4–20 mA NAMUR analogue output (NAMUR analogue output, see Glossary, page 50 (19.2 NAMUR)). The

transfer of analogue signals to higher-level control systems allows the pressure to be monitored continuously.



Voltage supply, 4–20 mA signal and Ethernet interface using M12 connector

The DG smart can be used for remote monitoring (e.g. using Thermal IQ™), local monitoring or for controlling Scada/ cloud software-supported smart production lines.

Permanent monitoring using the pressure sensor DG smart and digital connectivity for networked systems also enable predictive maintenance to be used, for example. That means less downtime (prevention of unnecessary safety shut-downs of the burner system).

Parameter settings using a local HMI interface or a web server reduce the time required for the commissioning process. The DG smart allows predictive analyses for trends or system optimization in gas and air applications.

2 Application examples

2.1 Air line with MIN, MAX pressure monitoring

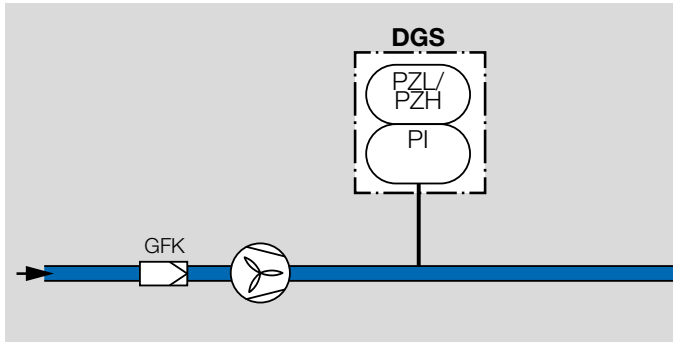

The static pressure is monitored by the MIN, MAX monitoring (PZL, PZH). If the supply air pressure is exceeded or undershot, the fan is switched on or off via the control unit.

2.2 Low and high gas pressure protection at the gas inlet section

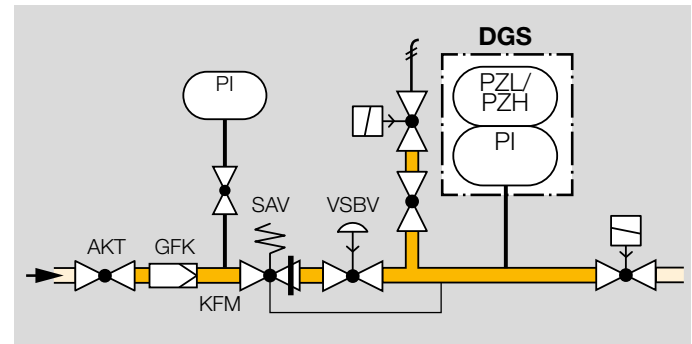

If the pressure is either too high or too low (PZL/PZH), the gas pressure sensor prevents the system starting or triggers a safety shut-down.

3 Certification

3.1 Certificate download

Certificates – see www.docuthek.com

3.2 Declaration of conformity



We, the manufacturer, hereby declare that the product DG smart with product ID No. CE-0085DP0152 complies with the requirements of the listed Directives and Standards.

Directives:

- 2014/30/EU – EMC
- 2011/65/EU – RoHS II
- 2015/863/EU – RoHS III

Regulation:

- (EU) 2016/426 – GAR

Standards:

- EN 1854:2022+A1:2023
- EN 60730-1:2016 + A1:2019 + A2:2022
- EN 60730-2-6:2016 + A1:2020
- EN 61508:2010, suitable for SIL 2

The relevant product corresponds to the tested type sample.

The production is subject to the surveillance procedure pursuant to Regulation (EU) 2016/426 Annex III Module D.

Elster GmbH

- » Pursuant to Article 4 paragraph 3 of the Pressure Equipment Directive (PED) 2014/68/EU, the device is not governed by the Pressure Equipment Directive.

3.3 IEC



The product DG smart complies with the listed Standards:

- IEC 60730-1:2022
- IEC 60730-2-6:2015 + AMD1:2019

3.4 SIL



For systems up to SIL 2 pursuant to IEC 61508.

Safety-specific characteristic values	
Diagnostic coverage DC	91%
Type of subsystem	Type B to IEC 61508-2:2010
Mode of operation	High demand mode pursuant to IEC 61508-4:2010
Mean probability of dangerous failure PFH _D	19.2×10^{-9} 1/h
Mean time to dangerous failure MT-TF _d	$1/PFH_D$
Safe failure fraction SFF	94.7%

3.5 REACH Regulation

The device contains substances of very high concern which are listed in the Candidate List of the European REACH Regulation No. 1907/2006. See Reach list HTS at www.docuthek.com.

3.6 China RoHS

Directive on the restriction of the use of hazardous substances (RoHS) in China. Scan of the Disclosure Table China RoHS2, see certificates at www.docuthek.com.

4 Function

4.1 Transmitter-, MIN-/MAX function

The pressure is detected by a sensor, processed and communicated via an analog value on the display and made available for signal processing to the higher-level control system.

The transmitter function is set as the factory default. The function can be extended by MIN, MAX monitoring, see parameter [Sensor function](#).

The MIN-/MAX function detects small pressure differences via the sensor system. If a MAX or MIN switching value is reached, it is processed and communicated to the higher-level control system via a safe 4–20 mA signal and/or a safety bus protocol.

4.2 Relative pressure (positive pressure)

See page 11 (5.1 Selection table) for the measuring range of the relative pressure sensor.

Relative pressure measurement is used to monitor the MIN/MAX switching pressure, e.g. in a fan application.

The relative pressure sensor records the difference between the ambient pressure and port **P1** or **P2**.

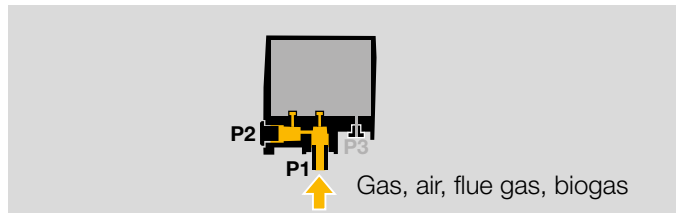

The relative pressure is measured at port **P1** or **P2**. The unused port remains closed.

4.3 Differential pressure

See page 11 (5.1 Selection table) for the measuring range of the differential pressure sensor.

Differential pressure measurement is used, for example, to safeguard an air flow rate or to monitor filters and fans.

The sensor records the difference between ports **P1** and **P2**.

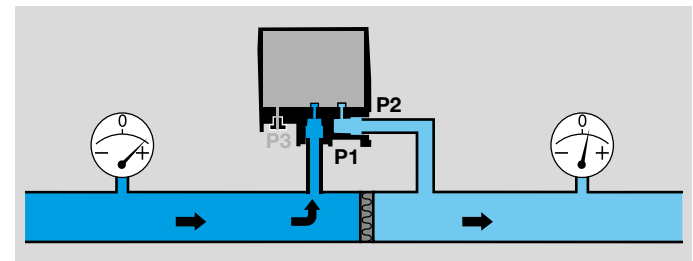

Use port **P1** for the higher absolute pressure (relative pressure) and **P2** for the lower pressure.

4.4 Part designations

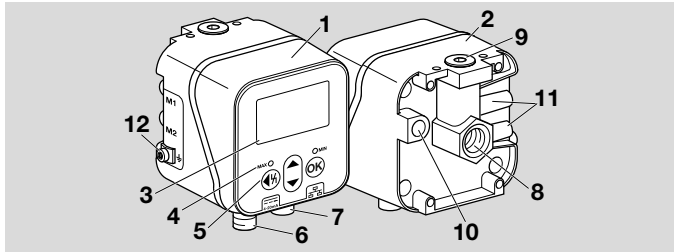

- 1 Upper housing section
- 2 Lower housing section
- 3 Display
- 4 Status display
- 5 User keys
- 6 Voltage supply/4-20 mA signal
- 7 Ethernet
- 8 P1, Rp 1/4" (1/4" NPT) gas/air connection
- 9 P2, Rp 1/4" (1/4" NPT) gas/air connection
- 10 Breather orifice
- 11 M1, M2 pressure test nipples
- 12 M4 screw terminal for device grounding

4.5 Electrical connection

4.5.1 Voltage supply and 4-20 mA signal

Connect the 24 V DC voltage supply using the M12 connector (plug/plug, 4-pin, A-coded).

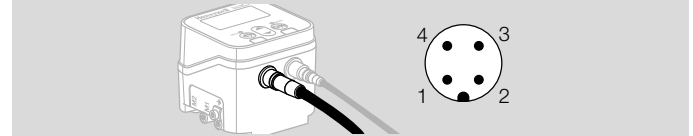

Pin	Function
1	+
2	4-20 mA
3 and 4	GND

4.5.2 Communication interface (Fast Ethernet)

Connect the Ethernet using the M12 connector (socket/coupling, 4-pin, D-coded).



Pin	Function
1	TD+
2	RD+
3	TD-
4	RD-

4.6 LED (colour/flash code)

Two changing colour LEDs show the status of the MAX/MIN function or a message.

» If the MAX/MIN function is disabled, the LEDs remain off during normal operation.



Colour and flash code

» The details refer to values which are parameterized, see page 12 (6 Parameter).

Colour	Meaning	Mode	Description
MAX LED			
Red	Alarm	Permanent	The pressure is greater than or equal to the setting value for the "MAX alarm" NFS parameter.
Yellow	Warning	Permanent	The pressure is greater than or equal to the setting value for the "MAX warning" NFS parameter.
Green	OK	Permanent	The pressure is less than the setting values for the "MAX alarm", "MAX warning" and "MAX switching value" NFS parameters.
Red	Recording	Flashing (1 Hz)	The pressure is greater than the setting value for the "MAX switching value" NFS parameter.
MIN LED			
Red	Alarm	Permanent	The pressure is less than or equal to the setting value for the "MIN alarm" NFS parameter.
Yellow	Warning	Permanent	The pressure is less than or equal to the setting value for the "MIN warning" NFS parameter.

Colour	Meaning	Mode	Description
Green	OK	Permanent	The pressure is greater than the setting values for the "MIN alarm", "MIN warning" and "MIN switching value" NFS parameters.
Red	Record	Flashing (1 Hz)	The pressure is less than the setting value for the "MIN switching value" NFS parameter.

MAX LED and MIN LED

Yellow	Initialization	Permanent	The unit is in Initialization mode.
Yellow	Setting the zero point	Flashing (5 Hz)	Ready for zero point adjustment (no fault may be active)
Red	Alarm	Permanent	Internal device error
Red	Overpressure/Underpressure detected	Flashing (1 Hz)	Overpressure or underpressure has been detected and the pressure is now back within the limit values (the unit must be re-set and checked).
Red	Overpressure/Underpressure active	Flashing (5 Hz)	Overpressure or underpressure is active. The pressure must be shut down.
Yellow	Permanent remote reset	Flashing (1 Hz)	Permanent remote reset (a warning is issued only if remote reset is parameterized)
Red	Too many remote resets	Flashing (1 Hz)	Too many remote resets (a fault lock-out occurs only if remote reset is parameterized)

5 Selection

5.1 Selection table

Description	Code	DGS	Condition
Gas pressure sensor	DGS	•	
Relative pressure sensor measuring range (positive pressure)			
No sensor	–	•	
0–100 mbar (0–40.1 "WC)	100	•	
0–350 mbar (0–140.7 "WC)	350	•	
0–1000 mbar (0–401 "WC)	1000	•	
Classification			
Not fail-safe (ePSD Cat A)	A	•	Regulating and control function, see page 50 (19 Glossary).
Fail-safe (ePSD Cat C)	C	•	Regulating and control function, see page 50 (19 Glossary).
Differential pressure sensor measuring range			
No sensor	–	•	Available shortly.
0–5 mbar (0–2 "WC)	5	–	Available shortly.
0–50 mbar (0–20 "WC)	50	–	Available shortly.
0–100 mbar (0–40.1 "WC)	100	–	Available shortly.
Pipe connection			
Rp internal thread	R	•	
NPT internal thread	N	•	
Electrical connection			
2 x M12 connectors	8	•	
Communication interface			
10/100 Mbit/s (Fast Ethernet)	TX	•	
Bus protocol			
Modbus TCP	-M	•	

Order example

DGS 100A-R8TX-M

5.1.1 Connections

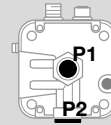

1 or 2 for positive pressure Rp ¼ (¼" NPT)
3 Breather orifice

Relative pressure (positive pressure)

Connect	Seal
P1	P2
P2	P1

Differential pressure

For the higher absolute pressure	For the lower absolute pressure
P1	P2

6 Parameter

6.1 General

The “Parameters” menu option is divided into “Safety parameters” (password-protected) and “Non-safety parameters”.

The value ranges of the parameters can be edited on the DG smart or using the integral web server.

6.2 Safety parameters

All safety parameters are password-protected. The user must be logged in to edit them.

Name	Translation	Value range	Factory default settings
<u>Sensor function</u>	Sensor function	Transmitter MIN MAX MAX and MIN function	Transmitter
<u>MAX switching value</u>	MAX switching value	Setting	0 mbar
<u>MIN switching value</u>	MIN switching value	Setting	0 mbar
<u>MAX reset</u>	MAX reset	Automatic Manual Remote	Automatic
<u>MIN reset</u>	MIN reset	Automatic Manual Remote	Automatic
<u>MAX delay time</u>	MAX delay time	Setting	0 s
<u>MIN delay time</u>	MIN delay time	Setting	0 s
<u>Overpressure value</u>	Overpressure	Setting	100% of the measuring range
<u>Zero adjustment</u>	Zero adjustment	Setting	0 mbar
<u>Output settings</u>	Output settings	Inactive NAMUR 4–20 mA	NAMUR
<u>Filter time</u>	Time to determine the pressure	0...3 s	0 s

6.2.1 Sensor function

Sensor function
Parameter settings:
Transmitter
Confirm Cancel

Value range	Description
Transmitter	The measurement is output using the analog signal. No check on MIN/MAX.
MAX	Transmitter function including checking the set MAX switching point.
MIN	Transmitter function including checking the set MIN switching point.
MAX and MIN	Transmitter function including checking the set MAX and MIN switching points.

6.2.2 MAX switching value

This parameter is used to set the switching point for the MAX check.

6.2.3 MIN switching value

This parameter is used to set the switching point for the MIN check.

6.2.4 MAX reset

Value range	Description
Automatic	Reset logic for the MAX function is set to automatic.
Manual	Reset logic for the MAX function is set to manual. (Only local reset is possible.)
Remote	Reset logic for the MAX function is set to remote control using bus communication. (Local reset is also possible.)

6.2.5 MIN reset

Value range	Description
Automatic	Reset logic for the MIN function is set to automatic.
Manual	Reset logic for the MIN function is set to manual. (Only local reset is possible.)
Remote	Reset logic for the MIN function is set to remote control using bus communication. (Local reset is also possible.)

6.2.6 MAX delay time

This parameter is used to set the delay time from 0–10 s for exceeding the MAX switching value.

6.2.7 MIN delay time

This parameter is used to set the delay time from 0–10 s for falling below the MIN switching value.

6.2.8 Overpressure value

This parameter is used to enter the value for the maximum overpressure at which the pressure sensor DG smart will switch to fault mode.

6.2.9 Zero adjustment

A zero point adjustment must be carried out during setting, commissioning or maintenance work.

The zero point adjustment should be carried out in normal operating temperature to obtain the best possible accuracy and reduce thermal effects.

6.2.10 Output settings

Value range	Description
Inactive	This parameter is used to disable the 4–20 mA output.
NAMUR	Activate 4–20 mA output (using the appropriate NAMUR error information ¹⁾).
4–20 mA	Activate 4–20 mA output (without NAMUR error rectification). The output is switched off (0 mA) in the event of an error (e.g. MAX/MIN switching pressure, over-/undervoltage, over-/undertemperature or over-/underpressure).

¹⁾ Error information, see page 30 (9 Output signal coding).

6.2.11 Filter time

Value range	Description
0...3 s	Pressure fluctuations in burners over an adjustable time are taken into account in filtered (mean) form when recording the pressure. The required filter time can be adjusted in 0.1 s steps using this parameter. The measured pressure is filtered for the set time and forwarded to the 4–20 mA output.

6.3 Non-safety parameters

Name	Translation	Value range	Factory default settings
<u>MAX warning</u>	MAX warning	Setting	0 mbar
<u>MAX alarm</u>	MAX alarm	Setting	0 mbar
<u>MIN warning</u>	MIN warning	Setting	0 mbar
<u>MIN alarm</u>	MIN alarm	Setting	0 mbar
<u>Communication</u>	Communication	IP address* Netmask* Gateway address* MAC address*	192.168.0.200

* Login required.

6.3.1 MAX warning

This parameter is used to set the switching point for the MAX warning. The colour of the LED then changes to yellow.

6.3.2 MAX alarm

This parameter is used to set the switching point for the MAX alarm. The colour of the LED then changes to red.

6.3.3 MIN warning

This parameter is used to set the switching point for the MIN warning. The colour of the LED then changes to yellow.

6.3.4 MIN alarm

This parameter is used to set the switching point for the MIN alarm. The colour of the LED then changes to red.

6.3.5 Communication

Value range	Description
IP address	This parameter enables the IP address to be edited.
Subnet	This parameter enables the subnet IP address to be edited.
Gateway	This parameter enables the gateway IP address to be edited.
MAC address	This fixed parameter displays the MAC address.

6.4 Settings

Settings
Display
Password

Display

Name	Translation	Value range	Factory default settings
Measuring unit	Measuring unit	mbar, kPa, PSI, inch WC	mbar
Decimal separator	Decimal separator	Point "." or comma ","	Point "."
Brightness	Brightness	Setting: Display brightness	100%
Temperature unit	Temperature unit	C, F, K	C
Language	Language	English	English

Password

Display	Translation	Value range	Factory default settings
Password	Password	xxxx	0000

6.4.1 Measuring unit

Display settings	
Measuring unit	mbar
Decimal separator	
Brightness	100%
Temperature	C

Password-protected parameters can only be edited on the DG smart or using the web server if the user is logged in.

Value range	Description
mbar	mbar is displayed.
kPa	kPa is displayed.
PSI	PSI is displayed.
"WC	"WC is displayed.

This parameter is used to set the measuring unit to display the pressure. The parameterization and data transfer continue to take place using the specified unit.

6.4.2 Temperature unit

Value range	Description
C	Celsius is displayed.
F	Fahrenheit is displayed.
K	Kelvin is displayed.

6.4.3 Decimal Separator

Display: "." or "," as the decimal separator.

6.4.4 Brightness

This parameter enables the display brightness to be adjusted.

6.4.5 Language

The user and display language is English.

6.4.6 Password

A four-digit numerical password enables the user to restrict access to the unit.

6.5 Statistics

Name	Translation	Value range
Event history	Event history	Information on the event history, device statistics and customer statistics is displayed in plain text.
Device statistics	Device statistics	
Customer statistics	Customer statistics	
Clear event history*	Clear event history	Resetting the event history
Clear customer statistics*	Clear customer statistics	Resetting the customer statistics

* Login required.

6.5.1 Event history

The event history saves the last 10 events. As soon as an event (for example an error) occurs in the unit, the current status is saved in the history.

The additional information in the history are as follows:

- Time of the event
- Error code (in the event of an error)
- Pressure
- Mains voltage
- Temperature

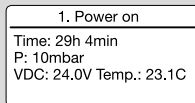
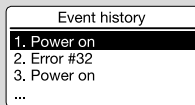

6.5.2 Device statistics

Device statistics are provided for diagnostic purposes and cannot be reset by the customer. They cover the entire service life of the unit as they cannot be reset.

- Counters
- Error
- Duration
- Values

Counter	
1. Error #32	8
2. Error #78	5
...	

Errors	
1. Error	12
2. Error	27
3. Error	1
4. Error	3

Device endurance	
1. Max power on	4h 30min
2. Max overtemp.	0h 10min
3. Power on total	29h 30min

Device extreme values	
1. Max. temp.	32.2C
2. Min. temp.	5.0C
3. Max. pressure	78.1mbar
4. Min. pressure	0.1mbar

6.5.3 Customer statistics

The same counters are evaluated in the customer statistics as in the device statistics and the statistics can be reset by the customer.

6.5.4 Clear event history

The event history can be reset by the user (login required).

6.5.5 Clear customer statistics

The customer statistics can be reset by the user (login required).

6.6 Information

Name	Translation	Value range
.Device name	Gerätname	The device name, network configuration and firmware are displayed in plain text.
.Network	Network	
.Firmware	Firmware	

6.6.1 Device name

The device name is displayed.

6.6.2 Firmware

The current software is displayed.

6.6.3 Network

The current network configuration is displayed.

6.7 Service

Name	Value range
.Firmware upgrade	Firmware upgrade

6.7.1 Firmware

The Service section can only be accessed via the web server, see page 22 (7 Web server).

7 Web server

The web server can be accessed using the preset IP address 192.168.0.200 (subnet mask 255.255.255.0). The IP address of the computer must be in the same network as the DGS for the parameterization process.

The IP address can be changed using the “Communication” parameter, see [Communication](#).

Select

When you first make the selection in the web server, follow the browser prompt and accept the certificate. After clicking on “Extended”, select the link “Continue to 192.168.0.200 (insecure)”.

Safety parameters are password-protected. They can be edited if the user is logged in (the icon at the top right in the following screen).

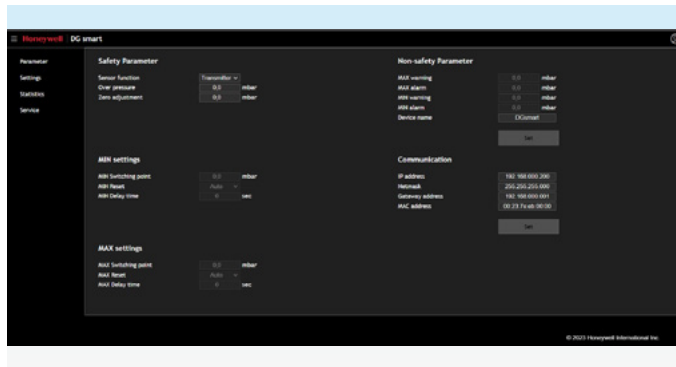

Safety and non-safety parameters

Each entry must be confirmed using the “SET” button.

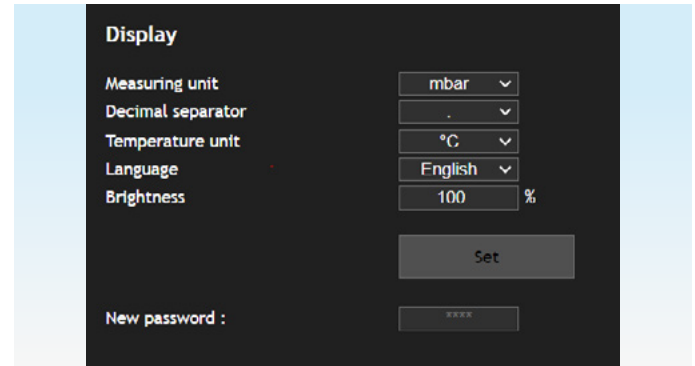

Settings

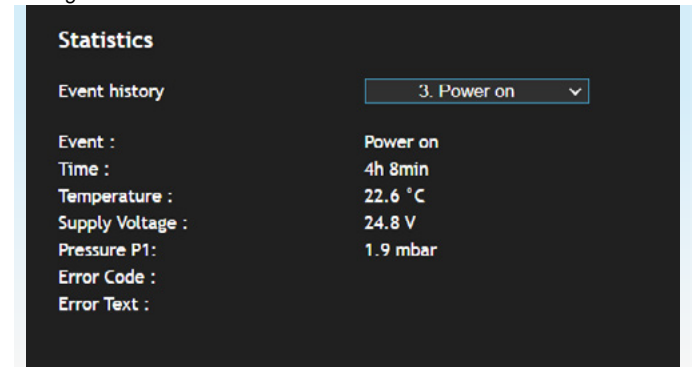

Event history

Statistics can be displayed without having to log in.

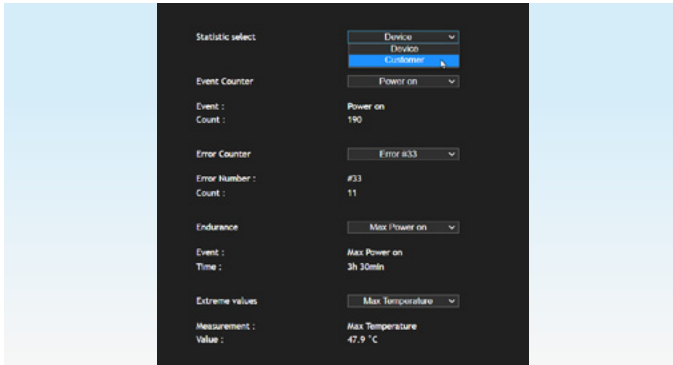

Device and customer statistics

The event history and customer statistics can be reset if the user is logged in.

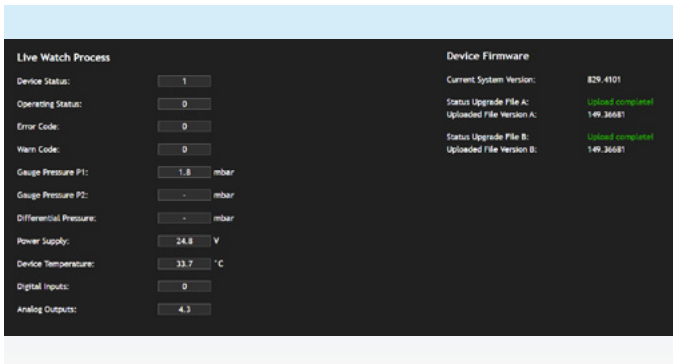

Service

Process data are displayed in the “Service” section. A firm-ware upgrade can be performed if the user is logged in.

8 Modbus TCP

The Modbus protocol is a communications protocol based on a Client/Server architecture. Once the TCP/IP connection between client (PLC) and server (DG smart) has been established, useful data can be transferred via this connection as often and in as great an amount as required. The PLC and DG smart can establish up to 3 parallel TCP/IP connections at the same time. Using the function codes 3, 6 and 16, data can be transferred to and from the DG smart. New data are available every 100 ms.

8.1 Modbus holding registers

Communication with Modbus TCP is achieved using TCP port 502 and the IP address.

The holding registers (16-bit values, read and write (r/w)) are addressed using an internal register number. All registers = r; register 001 = r/w.

The data ranges can be read in each register or, if it exists, in summary form using a register number.

8.1.1 Process data

Holding register	Description	Value range/Unit
101	Relative pressure at P1	mbar (signed) * 10
102	Relative pressure at P2	mbar (signed) * 10
103	Differential pressure	mbar (signed) * 10
104	Supply voltage	V * 10
105	Device temperature	K * 10
106	4–20 mA analogue output signal	mA * 10
107	Error code, see operating instructions, Error code . High byte = module/low byte = code	

Holding register	Description	Value range/Unit
108	Warning code, see operating instructions, Error code . High byte = module/low byte = code	
109	Device status	0 = Initialization 1 = Normal operation 5 = Device error 9 = Safety shut-down 10 = Fault lock-out
110	Operating status	0 = Transmitter function (no MIN or MAX function active) 1 = MAX function 2 = MAX switching value exceeded 3 = MIN function 4 = MIN switching value undershot 5 = MIN and MAX function 6 = Overpressure active 7 = Underpressure active 8 = Defective sensor
111	MAX switching point	mbar * 10
112	MIN switching point	mbar * 10
113	Status bits: Bit 0: MAX warning Bit 1: MAX alarm Bit 2: MAX switching point detected Bit 3: MIN warning Bit 4: MIN alarm Bit 5: MIN switching point detected Bit 6: Supply voltage OK	
001	Remote reset via bus	

8.1.2 Event history

Holding register 57348

Number of registers: 80 (8 registers per event)

The event history saves the last 10 events in the structure described below.

Offset	Description	Value range/Unit
0	Event time	Low word of the time, s
1	Event time	High word of the time, s
2	Error code, see operating instructions, Error code .	
3	Supply voltage	V * 10
4	Temperature	K * 10
5	High byte event Low byte short error code	Event IDs: 1 = Device error 2 = Fault lock-out 3 = Safety shut-down 4 = Warning 8 = Error 9 = Parameter changed 10 = Statistics deleted 11 = Power On 12 = System error 13 = Login failed
6	Pressure	mbar * 10
7	Operating status	0 = Transmitter function (no MIN or MAX function active) 1 = MAX function 2 = MAX switching value exceeded 3 = MIN function 4 = MIN switching value undershot 5 = MIN and MAX function 6 = Overpressure active 7 = Underpressure active 8 = Defective sensor

8.1.3 Device statistics

Counters and extreme values		
Internal register*	Description	Value range/ Unit
3456	Power On counter	Low word
3457	Power On counter	High word
4378	Reset counter	Low word
4379	Reset counter	High word
3458	Total duty cycle	Low word, s
3459	Total duty cycle	High word, s
4650	Max. duty cycle duration	Low word, s
4651	Max. duty cycle duration	High word, s
4654	Max. overtemperature duration	Low word, s
4655	Max. overtemperature duration	High word, s
4390	Extreme value: Maximum temperature	Low word, K * 10
4391	Extreme value: Minimum temperature	High word, K * 10
5139	Extreme value: Maximum pressure	Low Word, mbar (signed) * 10
5140	Extreme value: Minimum pressure	High Word, mbar (signed) * 10

In contrast to the holding registers, the internal registers can only be read individually using Modbus.

Fault counter		
Internal register*	Description	
3210	Too many remote resets	Too many remote resets
3252	Permanent remote reset	Permanent remote reset
3232	Error under-/overvoltage	Error supply voltage too low/too high
3413	Warning/Error undertemperature	Warning/error ambient temperature low
3416	Warning/Error overtemperature	Warning/error ambient temperature high
3275	MIN pressure	MIN switching pressure
3276	MAX pressure	MAX switching pressure
3277	Error underpressure	Underpressure error
3278	Error overpressure	Overpressure error
3273	4–20 mA interrupted	4–20 mA signal missing/interrupted.
3274	4–20 mA impedance error	4–20 mA signal impedance error
3299	Internal error	Internal device error

In contrast to the holding registers, the internal registers can only be read individually using Modbus.

8.1.4 Customer statistics

Counters and extreme values		
Internal register*	Description	Value range/ Unit
3756	Power On counter	Low word
3757	Power On counter	High word
4380	Reset counter	Low word
4381	Reset counter	High word
3758	Total duty cycle	Low word, seconds
3759	Total duty cycle	High word, seconds
4652	Max. duty cycle duration	Low word, seconds
4653	Max. duty cycle duration	High word, seconds
4656	Max. overtemperature duration	Low word, seconds
4657	Max. overtemperature duration	High word, seconds
4393	Extreme value: Maximum temperature	Low word, K * 10
4394	Extreme value: Minimum temperature	High word, K * 10
5141	Extreme value: Maximum pressure	Low Word, mbar (signed) * 10
5142	Extreme value: Minimum pressure	High Word, mbar (signed) * 10

In contrast to the holding registers, the internal registers can only be read individually using Modbus.

Fault counter		
Internal register*	Description	
3510	Too many remote resets	Too many remote resets
3552	Permanent remote reset	Permanent remote reset
3532	Error under-/overvoltage	Error supply voltage too low/too high
3713	Warning/Error undertemperature	Warning/error ambient temperature low
3716	Warning/Error overtemperature	Warning/error ambient temperature high
3575	MIN pressure	MIN switching pressure
3576	MAX pressure	MAX switching pressure
3577	Error underpressure	Underpressure error
3578	Error overpressure	Overpressure error
3573	4–20 mA interrupted	4–20 mA signal missing/interrupted.
3574	4–20 mA impedance error	4–20 mA signal impedance error
3599	Internal error	Internal device error

In contrast to the holding registers, the internal registers can only be read individually using Modbus.

8.1.5 Settings

Register 57349

Number of registers: 10

Offset	Holding register	Description		Value range
0	-	Device name	Device name	Length: 20 bytes

8.1.6 Safety parameters

Holding register 57386

Number of registers: 9

Offset	Internal register	Description		Value range/Unit
0	5120	Sensor function	Sensor function	0 = Transmitter 1 = MIN 2 = MAX 3 = MAX and MIN function
1	5121	MAX switching value	MAX switching value	mbar * 10
2	5122	MIN switching value	MIN switching value	mbar * 10
3	5123	MAX reset	MAX reset	0 = Automatic reset 1 = Manual reset 2 = Remote reset via bus
4	5124	MIN reset	MIN reset	0 = Automatic reset 1 = Manual reset 2 = Remote reset via bus
5	5125	MAX delay time	MAX delay time	seconds
6	5126	MIN delay time	MIN delay time	seconds
7	5127	Overpressure value	Overpressure	mbar * 10
8	5128	Zero adjustment	Zero adjustment	mbar (signed) * 10

In contrast to the holding registers, the internal registers can only be read individually using Modbus.

8.1.7 Non-safety parameters

Holding register 57398

Number of registers: 4

Offset	Internal register*	Description		Value range/Unit
0	5131	MAX warning	MAX warning	mbar * 10
1	5132	MAX alarm	MAX alarm	mbar * 10
2	5133	MIN warning	MIN warning	mbar * 10
3	5134	MIN alarm	MIN alarm	mbar * 10

In contrast to the holding registers, the internal registers can only be read individually using Modbus.

8.1.8 Hardware parameters

Holding register 57389

Number of registers: 1

Offset	Internal register*	Description	Value range
0	3167	Device type	0 = ePSD Cat A, 100 mbar 1 = ePSD Cat A, 350 mbar 2 = ePSD Cat A, 1000 mbar 6 = ePSD Cat C, 100 mbar 7 = ePSD Cat C, 350 mbar 8 = ePSD Cat C, 1000 mbar 9 = ePSD Cat C, 5 mbar 10 = ePSD Cat C, 50 mbar 11 = ePSD Cat C, 100 mbar

In contrast to the holding registers, the internal registers can only be read individually using Modbus.

8.1.9 Bus parameters

Holding register 57399

Number of registers: 6

Offset	Internal register*	Description	Value range
0	4206	IP address	Low byte: XXX.000.000.000 High byte: 000.XXX.000.000
1	4207	IP address	Low byte: 000.000.XXX.000 High byte: 000.000.000.XXX
2	4208	Subnet	Low byte: XXX.000.000.000 High byte: 000.XXX.000.000
3	4209	Subnet	Low byte: 000.000.XXX.000 High byte: 000.000.000.XXX
4	4210	Gateway	Low byte: XXX.000.000.000 High byte: 000.XXX.000.000
5	4211	Gateway	Low byte: 000.000.XXX.000 High byte: 000.000.000.XXX

In contrast to the holding registers, the internal registers can only be read individually using Modbus.

9 Output signal coding

NAMUR

NAMUR NE 43 (standardization of the signal level for the failure information of digital transmitters with an analogue output signal) is used as a reference for error information (in addition to the measuring information).

Current range [mA]	Description
22.0	Overpressure detected
21.0	MAX switching pressure detected
21.0	Upper error range
20.5	Upper tech range
20.0	Upper nominal range
4.0	Lower nominal range
3.8	Lower tech range
3.6	Lower error range
3.0	MIN switching pressure detected
2.0	Over-/undervoltage or over-/undertemperature detected
1.0	Underpressure detected
0	Output off (internal or device error)

4–20 mA

The 4–20 mA output supplies the current pressure in the form of an analogue value. Any error state corresponds to 0 mA here.

The pressure measuring range is scaled to 4–20 mA.

10 Project planning information

10.1 Installation

Long-term use in the upper ambient temperature range accelerates the ageing of the elastomer materials and reduces the service life (please contact manufacturer).

Continuous operation with gases containing more than 0.1 %-by-vol. H_2S or ozone concentrations exceeding $200 \mu g/m^3$ accelerate the ageing of elastomer materials and reduce the service life.

Condensation must not be allowed to get into the housing. At subzero temperatures, malfunctions/failures due to icing can occur.

Avoid strong impact on the unit.

10.1.1 Installation position

Installation in the vertical or horizontal position, not upside down. The recommended installation position is vertical.

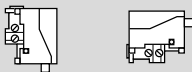

A zero point adjustment must be carried out during the commissioning or maintenance procedure to avoid discrepancies. The zero point adjustment should be carried out in normal operating temperature to obtain the best possible accuracy and reduce thermal effects.

10.2 MIN and MAX switching point range

The MIN/MAX switching value must be within the specified MAX/MIN switching point range, see Technical data, measuring range, page 35 (12.4 Measuring range).

The switching point is set in the safety parameters, see [MAX/MIN switching value](#).

10.3 Hydrogen



Other hydrogen-compatible products can be found here: [Technical Information, Products for hydrogen](#).

11 Accessories

11.1 Test key PIA



For zero point adjustment or to test the MIN function, the DG smart can be vented using the PIA test key (contains non-ferrous metals).

Order No.: 74329466

11.2 Tube set

To be used with air only.



Tube set with 2 m PVC tube (\varnothing 4,75 x 1 mm), 2 duct connection flanges with screws, R 1/4 and R 1/8 connecting nipples.

Order No.: 74912952.

11.3 Fastening set with screws, U-shape bracket

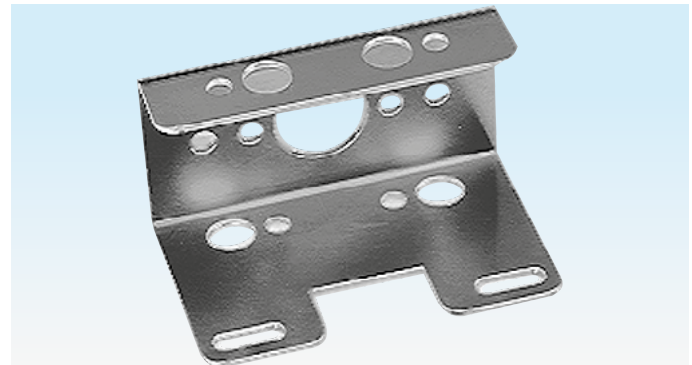

Order No.: 74915387

11.4 Connecting set for DGS and DG

A DGS used as a relative pressure sensor (positive pressure) can be connected to a pressure switch (DG..U, DG..B, DG..H, DG..N) with a mechanical switching function.



Order No.: 74912250

12 Technical data

12.1 Ambient conditions

Icing, condensation and dew in and on the unit are not permitted.

Medium and ambient temperatures during operation (to EN 1854:2022+A1:2023 and FM 3510): 0 to 60°C (32 to 140°F).

Extended medium and ambient temperature range: -20 to +70°C (4 to 158°F). In extended temperature ranges, outside the range from 0 to 60°C (32 to 140°F), an increased measuring deviation must be expected (up to 0.5% FS/K) and the DG smart no longer satisfies the accuracy requirements set out in EN 1854:2022+A1:2023 and FM 3510.

Long-term use in the upper ambient temperature range accelerates the ageing of the elastomer materials and reduces the service life (please contact manufacturer).

Storage and transport temperatures: -20 to +60°C (4 to 140°F).

Avoid direct sunlight or radiation from red-hot surfaces on the unit. Note the maximum medium and ambient temperatures!

Avoid corrosive influences, e.g. salty ambient air or SO₂.

The unit may only be stored/installed in enclosed rooms/buildings.

The unit is suitable for a maximum installation height of 2000 m AMSL.

Enclosure: IP 65.

This unit is not suitable for cleaning with a high-pressure cleaner and/or cleaning products.

12.2 Mechanical data

Gas types for relative pressure sensor: natural gas, town gas, LPG (gaseous), flue gas, biogas (max. 0.1 %-by-vol. H₂S), hydrogen and air.

Gas types for differential pressure sensor: air.

The gas must be clean and dry in all temperature conditions and must not contain condensate.

Max. inlet pressure $p_{\max.}$ = withstand pressure, measuring range and max. deviations, see page 35 (12.4 Measuring range).

Maximum leakage rate Q_L = max. 20 cm³/h.

Upper housing section: steel fibre reinforced PBT plastic with low gas release.

Lower housing section: AISi 12.

Rp 1/4 (1/4" NPT) connecting thread.

Weight: 450 g.

12.3 Electrical data

100% duty cycle (continuous operation).

Safety class: 3.

DGS..A (ePSD Cat A): non-fail-safe regulating and control functions.

DGS..C (ePSD Cat C): fail-safe regulating and control functions.

Mains voltage: 24 V DC, ±20%, SELV/PELV, power: ≥ 5 W.

Power consumption: < 2.5 W.

Overvoltage category III.

Communication interface: 10/100 Mbit/s (Fast Ethernet).

Bus protocol: Modbus TCP.

Electrical connection

Voltage supply and 4–20 mA signal: M12 connector (plug/plug, 4-pin, A-coded).

4–20 mA output signal load impedance: $\leq 500 \Omega$.

Ethernet: M12 connector (socket/coupling, 4-pin, D-coded).

Cable cross-section: min. 0.34 mm^2 (AWG 22), max. 1.0 mm^2 (AWG 17, depending on the connector used).

Functional earth: ground terminal for connecting fine-strand cables up to 4 mm^2 .

Internal fuse: non-replaceable fuse (slow-acting, 250 mA).

12.4 Measuring range

Relative pressure (positive pressure)

Measuring range	Withstand pressure	MAX/MIN switching point range
0–10 kPa (0–100 mbar)	60 kPa (600 mbar)	1.1–10 kPa (11–100 mbar)
0–35 kPa (0–350 mbar)	60 kPa (600 mbar)	2.4–35 kPa (24–350 mbar)
0–100 kPa (0–1000 mbar)	150 kPa (1500 mbar)	6.7–100 kPa (67–1000 mbar)

Sensor type: Stainless steel, media-insulated.

12.4.1 Overall accuracy to EN 1854:2022+A1:2023

Measuring range	25°C [% FSO]*	0–60°C [% FSO]	-20–0°C, 60–70°C [% FSO]
0–10 kPa (0–100 mbar)	$\leq \pm 0.5$	$\leq \pm 1.7$	$\leq \pm 10$
0–35 kPa (0–350 mbar)	$\leq \pm 0.5$	$\leq \pm 1.0$	$\leq \pm 5$
0–100 kPa (0–1000 mbar)	$\leq \pm 0.2$	$\leq \pm 1.0$	$\leq \pm 5$

* Includes repeat accuracy, hysteresis and linearity using the limit point method.

The overall accuracy E of a specific inlet pressure is calculated on the basis of various factors.

$$E = (\sqrt{E_R^2 + E_H^2 + E_D^2 + E_{Temp}^2 + E_L^2 + E_T^2 + E_O^2 + E_S^2}) \pm E_{Res}$$

Factors		[% FSO]		
		0–100 mbar	0–350 mbar	0–1000 mbar
E_R	Repeat accuracy	0.13	0.06	0.06
E_H	Hysteresis	0.13	0.06	0.06
E_D	Deviation	0.25	0.19	0.13
E_{Temp}	Temperature sensitivity	1.50	0.69	0.75
E_L	Linearity	0.23	0.44	0.13
E_T	Transfer ratio (4–20 mA)	0.15	0.14	0.10
E_O	Offset	0.38	0.31	0.06
E_S	Changes in supply voltage	0.06	0.06	0.06
E_{Res}	Resolution (4–20 mA)	0.03	0.03	0.03

12.5 Safety instructions

Software class: corresponds to software class C which operates in a similar double-channel architecture with comparison.

12.6 Dimensions

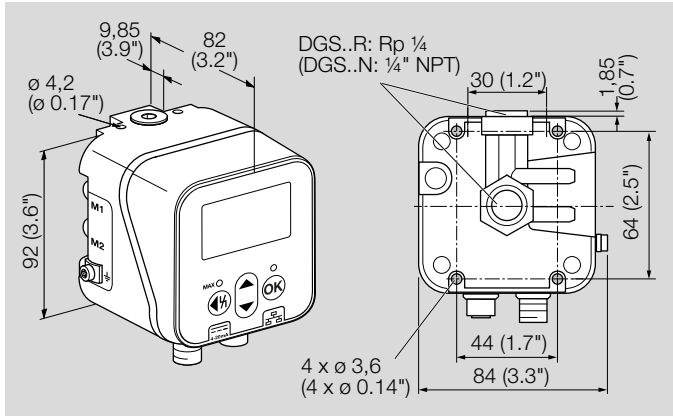

13 Converting units

See www.adlatus.org

14 Maintenance cycles

In order to ensure smooth operation, check the tightness and function of the pressure sensor every year.

» After carrying out the maintenance work, check for tightness.

A zero point adjustment must be carried out at operating temperature after the maintenance work has been completed to ensure the best possible accuracy.

15 Cyber and IT security

The digitalization of production provides plenty of versatility for collecting and using data. A secure network configuration must be established to provide protection from cyber crime. The following information is designed to describe time-tested practices for cyber and IT security.

15.1 Physical device protection

Only operate the unit in the protected range of a safety zone with (restricted) access for authorized personnel.

Protect the (control) cables for the unit and all externally connected components from access by unauthorized personnel so that the unit cannot be tampered with.

Anti-tampering seal

Only use devices with an undamaged seal. Otherwise, the device may have been opened, tampered or damaged and pose a risk for the system.

Fieldbus interface

To prevent misuse caused by changing security-critical data, for example, protect the fieldbus interface and communication network from unauthorized access.

Secure decommissioning

The unit contains sensitive data and should be kept in a safe, inaccessible location when it is not in use.

When the unit is finally decommissioned or replaced, delete all the security-sensitive data and dispose of the unit, including its electronic PCBs, irreversibly.

15.2 Securing the network

A securely planned, designed and operated network architecture ensures that network access delivers adequate security.

15.2.1 Physical separation

The unit should be installed and connected in a control system network isolated from the company network.

This method ensures a high level of security. There is no physical connection between the control system network and the company network/Internet. The use of wireless devices to control the control system network may endanger the security of the network.

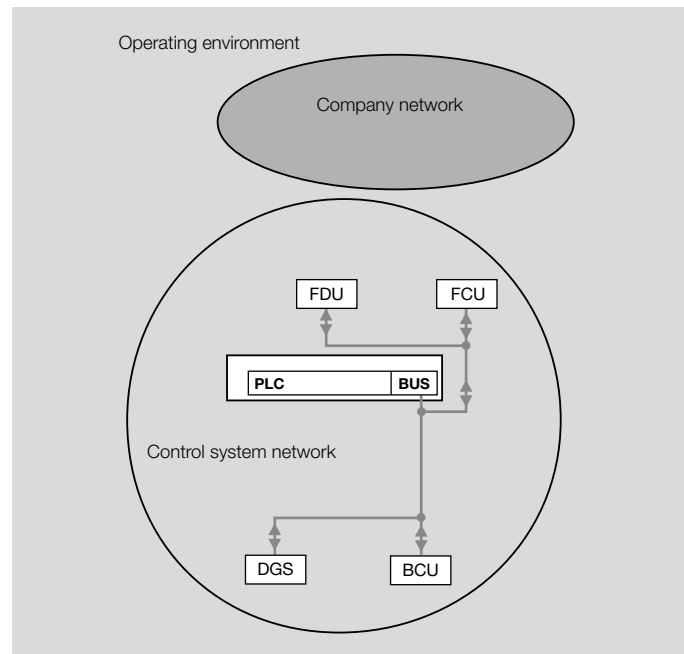

Physical separation between the control system network and company network

Legend:

- BCU = burner control unit
- DGS = gas pressure sensor
- FCU = protective system control
- FDU = flame detector
- PLC = programmable logic controller
- BUS = bus system, e.g. Modbus

15.2.2 Firewall isolation

Only use a connection between the control system network and the company network which is secured by a firewall (secure gateway). Unknown sources and enquiries from unreliable clients are filtered out.

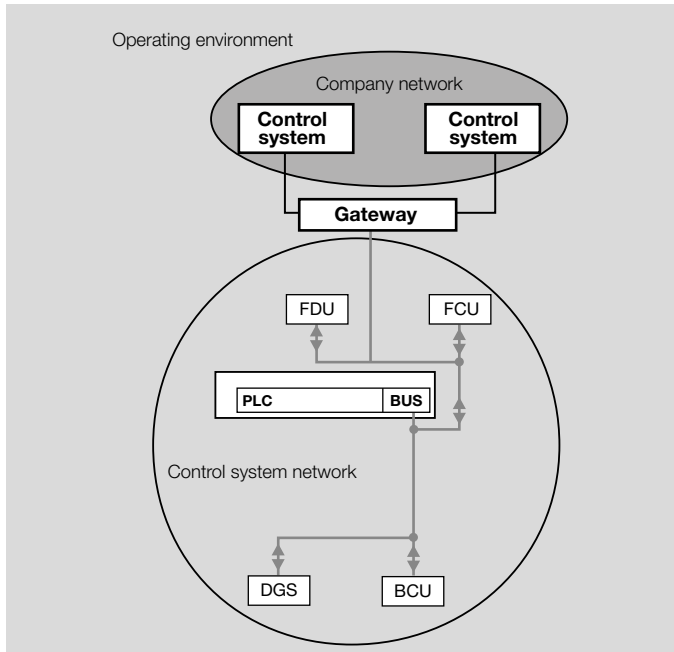

Isolation using a gateway

Legend:

- BCU = burner control unit
- DGS = gas pressure sensor
- FCU = protective system control
- FDU = flame detector

- PLC = programmable logic controller
- BUS = bus system, e.g. Modbus

A secure gateway includes a VPN set-up with defined authorized users.

The requirements for using VPN are as follows:

- Secure VPN service
- Secure configuration of the VPN clients for remote access
- Secure standard settings on the VPN components

The following should be noted to ensure that a control system network has a secure configuration:

- If the firewall port is open or the function is enabled, this should always be done with the full understanding of the relevant service.
- A standard configuration is not a secure solution.
- All communication to the network should be disabled apart from explicitly required data streams.

15.2.3 Network address translation (NAT)

NAT allows the partial isolation of the external network from the control system network. If NAT is correctly configured, it should not permit any connection from an external system to the control system.

The correct configuration depends on the manufacturer's requirements for the individual system components.

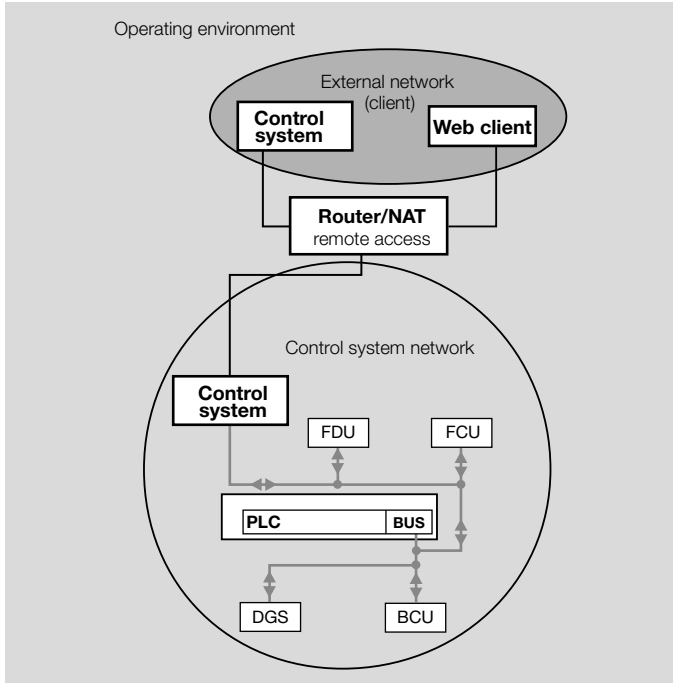

Network address translation (NAT)

Legend:

- BCU = burner control unit
- DGS = gas pressure sensor
- FCU = protective system control
- FDU = flame detector
- PLC = programmable logic controller
- BUS = bus system, e.g. Modbus

15.3 Communications protocols

15.3.1 Communications protocols

The communications protocols supported in the unit do not support any cyber or IT security functions.

The following recommendations and time-tested methods should be considered.

Ultimately, it is the responsibility of the operator to use the unit in a secure communications environment. “If, for example, insecure communications protocols, encryption algorithms or authentication mechanisms are used for remote maintenance, vulnerabilities may be created. A connected network operated by a third party can also be compromised by remote maintenance interfaces with inadequate security.” (IT principles compendium).

15.3.2 HTTPS (Hypertext Transfer Protocol Secure)

A secure, certificate-based HTTPS connection is used for communication with the web server, data monitoring and for changing device parameters.

Firmware upgrade in HTTP

The system switches to the HTTP protocol for firmware upgrades for performance reasons. After the firmware has been upgraded, the unit automatically restarts and the HTTPS connection is re-established.

15.4 Reporting vulnerabilities

A vulnerability is an error or a weakness in the software. It can be exploited to reduce the software’s operability or security functions. Honeywell reviews all vulnerability reports relating to Honeywell products and services.

For further information, see www.honeywell.com/product-security.

Report a vulnerability for a Honeywell product in the [Report A Vulnerability Issue](#) section.

16 Open source software licences

Freely available software was used to create the DG smart.

For the terms and conditions of the open source software licences, see www.docuthek.com, [OSS Licenses](#).

17 Safety-specific characteristic values for SIL

Certificates – see www.docuthek.com.

For systems up to SIL 2 pursuant to IEC 61508.

Safety-specific characteristic values	
Diagnostic coverage DC	91%
Type of subsystem	Type B to IEC 61508-2:2010
Mode of operation	High demand mode pursuant to IEC 61508-4:2010
Mean probability of dangerous failure PFH_D	19.2×10^{-9} 1/h
Mean time to dangerous failure $MT-TF_d$	$1/PFH_D$
Safe failure fraction SFF	94.7%

For a glossary of terms, see page 50 (19 Glossary).

17.1 Designed lifetime

Designed lifetime (based on date of manufacture) in accordance with EN 1854:2022+A1:2023 for DG smart: 10 years.

18 Safety information in accordance with EN 61508-2

18.1 General

Scope of application

The pressure sensor DG smart is used in safety-related (sub)systems as specified in IEC 61508.

Depending on the version, the pressure sensor will record the relative pressure to the atmosphere and/or the pressure differential of air and non-aggressive gases.

The DG smart can be parameterized to set bespoke MIN and/or MAX pressure switching points. The measured pressure is supplied using an analogue 4–20 mA interface and also using Ethernet.

For further information, see page 4 (1 Application).

Type of action

The automatic action corresponds to Type 2 (IEC 60730-1).

Shut-down

Electronic shut-down, Action Type 2 Y (IEC 60730-1).

Software class

The software classification under standard IEC 61508 is software class C which operates in a similar double-channel architecture with comparison.

18.2 Interfaces

Electrical connection

Voltage supply (24 V DC, $\pm 20\%$, SELV/PELV) and 4–20 mA signal: M12 connector (plug/plug, 4-pin, A-coded).

4–20 mA output signal impedance: $\leq 500 \Omega$.

Ethernet: M12 connector (socket/coupling, 4-pin, D-coded).

Functional earth: ground terminal for connecting fine-strand cables up to 4 mm² (AWG 12).

Internal fuse: non-replaceable fuse (slow-acting, 250 mA).

Analogue interface

Depending on the parameterization, the analogue 4–20 mA interface complies with NAMUR NE 43:2021-07, see [Output settings](#). Alternative parameterization options: standard 4–20 mA, in which case every error state is 0 mA.

Depending on the sensor type, either the atmosphere-related pressure present or the differential pressure is converted into an analogue current. This can be read by a downstream (sub)system or a process control system.

The table below shows the range of the analogue output signal and defines all the ranges implemented on this basis. The analogue signal range is split into a range for normal operation and an upper and lower error range.

Output signal [mA]	Definition	Description
$I \leq 3.6$	Lower error range	Multiple error states are decoded.
$3.8 < I < 20.5$	Normal operation	May also be limited by MIN and/or MAX.
$I \geq 21$	Upper error range	Multiple error states are decoded.

The diagram describes the generic restrictions in the analogue output signal range.

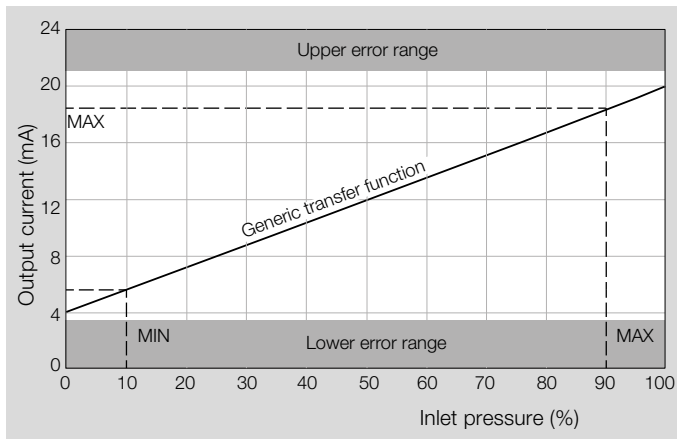

Generic transfer function

18.3 Communication

Communication interface

The Ethernet interface is accessible through a M12 connector (socket/coupling, 4-pin, D-coded). For details, see page 9 (4.5.2 Communication interface (Fast Ethernet)). The table below shows the general Ethernet specifications.

Category	Ethernet specification
IEEE standard	IEEE 802.3
Transfer rate (twisted pair)	10 MBit/s (10BASE-T) 100 MBit/s (100BASE-TX)
Auto negotiation	Enabled
Max. cable length	100 m
Duplex mode	Full duplex

Web server

The DG smart features a web server for configuration, monitoring status variables, firmware upgrades and general settings.

The web server can be accessed at <https://my.example.ip.address>. The default IP address is 192.168.0.200 (subnet mask 255.255.255.0). For more detailed information, see page 22 (7 Web server).

Protocols

The range or variants of the supported protocols depend on the firmware version of the DG smart. Some of the communications protocols can be used in safety-relevant (sub)systems as specified in IEC 61508. The table below contains a list of all the supported protocols.

Communications protocol	Supporting firmware version	Safety function
HTTP, HTTPS	All	No
Modbus TCP	All	No

Firmware upgrade

The firmware upgrade can be completed using the web server and the Service page, see page 22 (7 Web server).

18.4 SIL

Safety function

The analogue interface of the DG smart features three different safety functions, one of which is inherent while the other two can be configured by the user.

Transmitter function:

The output current corresponds to the actual system pressure within a tolerance of $\pm 5\%$ relative to the appropriate transmitter function. The system reverts to the safe state as soon as this tolerance is violated.

MIN function:

If the MIN switching point has been parameterized and set by the user, the safe state is achieved as soon as the system pressure falls below MIN, see the generic transmitter function, page 47 (18.2 Interfaces).

MAX function:

If the MAX switching point has been parameterized and set by the user, the safe state is achieved as soon as the system pressure exceeds MAX.

Definition of the safe state:

The safe state is defined as a current output signal within the lower or upper error range, which is achieved within the process safety time and after a safety function has been called. As a reference, see the output signal range table and generic transmitter function, page 47 (18.2 Interfaces).

The designations of all error states are listed in the table below.

Output current [mA]	Designation	Description
22 ± 0.1	Overpressure	The DG smart does not observe the overpressure range typical for this type.
21 ± 0.1	MAX error	MAX is parameterized and the system pressure is above MAX.
3 ± 0.1	MIN error	MIN is parameterized and the system pressure is below MIN.
2 ± 0.1	Supply voltage too low/too high./ Ambient temperature too low/too high.	The supply voltage range of 24 V DC, $\pm 20\%$ is not observed./ The ambient temperature range is not observed.
1 ± 0.1	Underpressure	The pressure has fallen below the underpressure range of the DG smart typical for this type.
0 ± 0.1	Internal device error	An internal device error has been detected.

If NAMUR has been deactivated for the output using the corresponding safety parameter, the unit is operated using standard 4–20 mA. The safe state is then always 0 mA.

From the point of view of IEC 61508, the currents and error states listed above are equivalent. The parameterized safety function is performed. The additional differentiation within the defined error ranges provides more detailed information for the user.

Classification

Class A (ePSD Cat A) and C (ePSD Cat C) regulating and control functions, see page 50 (19 Glossary).

SIL Safety Integrity Level

See page 45 (17 Safety-specific characteristic values for SIL).

19 Glossary

19.1 Regulating and control functions

Class A (ePSD Cat A): regulating and control functions which are not designed for the safety of the application to be dependent on them.

Class C (ePSD Cat C): regulating and control functions which are designed to prevent specific hazards, such as explosions, or whose failure may directly result in a hazard in the unit.

19.2 NAMUR

NAMUR stands for “Normenarbeitsgemeinschaft für Mess- und Regeltechnik in der chemischen Industrie” (Association for Standardization of Measurement and Control Engineering in the Chemical Industry).

A NAMUR NE 43:2021-07 analogue signal outputs failure information (error information) in addition to the measuring information.

19.3 Diagnostic coverage DC

Measure of the effectiveness of diagnostics, which may be determined as the ratio between the failure rate of detected dangerous failures and the failure rate of total dangerous failures

NOTE: Diagnostic coverage can exist for the whole or parts of a safety-related system. For example, diagnostic coverage could exist for sensors and/or logic system and/or final elements. Unit: %

see EN ISO 13849-1

19.4 Mode of operation

High demand mode or continuous mode

Operating mode, where the frequency of demands for operation made on a safety-related system is greater than one per year or greater than twice the proof-test frequency

see EN 61508-4

19.5 Probability of dangerous failure PFH_D

Value describing the likelihood of dangerous failure per hour of a component for high demand mode or continuous mode. Unit: 1/h

see EN 13611/A2

19.6 Mean time to dangerous failure $MTTF_D$

Expectation of the mean time to dangerous failure

see EN ISO 13849-1:2008

19.7 Safe failure fraction SFF

Fraction of safe failures related to all failures, which are assumed to appear

see EN 13611/A2

For more information

The Honeywell Thermal Solutions family of products includes Honeywell Combustion Safety, Eclipse, Exothermics, Hauck, Kromschroder and Maxon. To learn more about our products, visit ThermalSolutions.honeywell.com or contact your Honeywell Sales Engineer.

Elster GmbH
Strotheweg 1, D-49504 Lotte
T +49 541 1214-0
hts.lotte@honeywell.com
www.kromschroeder.com

© 2024 Elster GmbH

We reserve the right to make technical modifications in the interests of progress.

