

# Dual-Fuel Oxygen Burners OXY-THERM® FHR

## OPERATING INSTRUCTIONS

· Edition 02.22 · 32M-92012-04 · EN

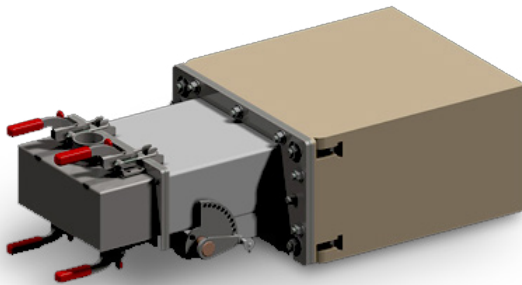

### CONTENTS

1 Safety . . . . .	1
2 Checking the usage . . . . .	1
3 Application requirements . . . . .	2
4 Installation . . . . .	2
5 Commissioning . . . . .	4
6 Maintenance . . . . .	4
7 Technical data . . . . .	4
8 Disposal . . . . .	7

### 1 SAFETY

#### 1.1 Please read and keep in a safe place

 Please read through these instructions carefully before installing or operating. Following the installation, pass the instructions on to the operator. This unit must be installed and commissioned in accordance with the regulations and standards in force. These instructions can also be found at [www.docuthek.com](http://www.docuthek.com).

#### 1.2 Explanation of symbols

**1, 2, 3, a, b, c** = Action

**→** = Instruction

#### 1.3 Liability

We will not be held liable for damage resulting from non-observance of the instructions and non-compliant use.

#### 1.4 Safety instructions

Information that is relevant for safety is indicated in the instructions as follows:

#### **DANGER**

Indicates potentially fatal situations.

#### **WARNING**

Indicates possible danger to life and limb.

#### **CAUTION**

Indicates possible material damage.

All interventions may only be carried out by qualified gas technicians. Electrical interventions may only be carried out by qualified electricians.

#### 1.5 Conversion, spare parts

All technical changes are prohibited. Only use OEM spare parts.

#### 1.6 Instructions provided by the company

Instructions provided by the company or individual responsible for the manufacture and/or overall installation of a complete system incorporating MAXON burners take precedence over the installation and operating instructions provided by MAXON. If any of the instructions provided by MAXON are in conflict with local codes or regulations, please contact MAXON before initial start-up of equipment.

### 2 CHECKING THE USAGE

OXY-THERM FHR burners can be used in furnaces and melters, steel reheat furnaces, linear hearth furnaces, rotary hearth furnaces, reverberatory furnaces, and other high temperature applications.

OXY-THERM FHR burners have a unique design which allows fuel interchangeability and easy maintenance. They are able to operate on fuel gas, light fuel oils or heavy fuel oils. Each fuel requires the use of separate nozzle inserts. Following plant safety procedures, the burner fuel inserts can be removed while the furnace is still in operation. In some cases, fuel oils may be atomized by fuel gases allowing simultaneous firing of two fuels. This function is only guaranteed when used within the specified limits – see page 4 (7 Technical data). Any other use is considered as non-compliant.

### 2.1 Type code

<b>OTFHR</b>	OXY-THERM FHR burner
	<b>Burner size</b>
<b>S</b>	Small
<b>M</b>	Medium
<b>L</b>	Large
<b>X</b>	Extra large
	<b>Medium type</b>
<b>G</b>	Gas
<b>O</b>	Oil
	<b>Fuel</b>
<b>-N</b>	Natural gas
<b>-X</b>	Special gas (ask engineering)
<b>-L</b>	Light fuel oil
<b>-H</b>	Heavy fuel oil
	<b>Fuel flow</b>
<b>036–667</b>	36–667 m <sup>3</sup> /h for gas burners
<b>041–569</b>	41–569 liters/h for oil burners
	<b>Block material</b>
<b>T</b>	Tank AZS 35-HP
<b>Z</b>	Zedpave
	<b>Burner block</b>
<b>1</b>	Yes
<b>0</b>	No
	<b>Conversion kit</b>
<b>000</b>	None
<b>041–569</b>	41–569 liters/h from gas to oil burners
<b>036–667</b>	36–667 m <sup>3</sup> /h from oil to gas burner

### 2.2 Part designations

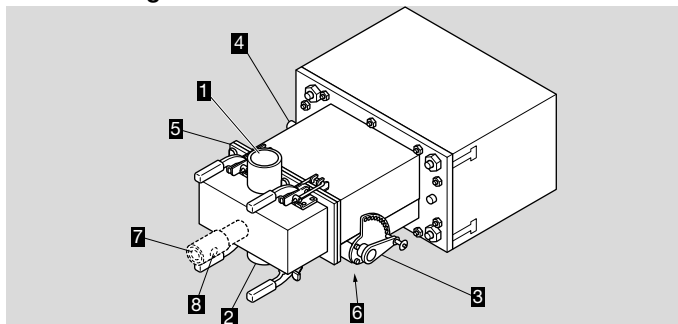

- 1 Fuel inlet
- 2 Oxygen inlet
- 3 Staged oxygen control valve
- 4 Oxygen pressure tap
- 5 Service plate
- 6 Cooling flow
- 7 1/2" NPT oil connection
- 8 1/2" NPT atomizing air connection

## 3 APPLICATION REQUIREMENTS

### 3.1 View port

→ A view port to observe burner flame is essential to inspect the flame aspect. Locate the view port downstream of the flame, looking back to the burner block. Make sure the complete flame can be evaluated.

### 3.2 Supporting burner air and gas piping

- The OXY-THERM FHR burner shall not be used as support for the piping to the burner. Gas and air piping shall be supported in such a way that no additional loads will be created on the burner. Unsupported piping puts stresses on the block/housing assembly.
- Flexible connections are typically recommended for all OXY-THERM FHR installations for both fuel and oxygen to prevent transferring mechanical loads or vibrations to the burner's ceramic parts. Quick connect/disconnect devices are recommended on the oxygen and fuel connections to ease fuel nozzle switching.

## 4 INSTALLATION

### 4.1 Storage of OXY-THERM FHR burners

OXY-THERM FHR Burners shall be stored dry (inside). Burner blocks have been cured carefully before shipment and shall be kept dry. Wetting of the blocks could result in premature failures.

### 4.2 Handling of OXY-THERM FHR burners

- OXY-THERM FHR burners are shipped as complete units. Handle burners with care, using proper equipment during unpacking, transport, lifting and installation.

### ⚠ WARNING

Any impact on the burner could result in damage.

- To prevent damage in transit, accessories such as flame rods, control valves and/or UV-scanners, may be packed separately and shipped loose.

### 4.3 Burner mounting

- The following views show two possible methods for mounting and holding an OXY-THERM FHR burner block and frame assembly in place.

#### Typical burner mounting arrangement

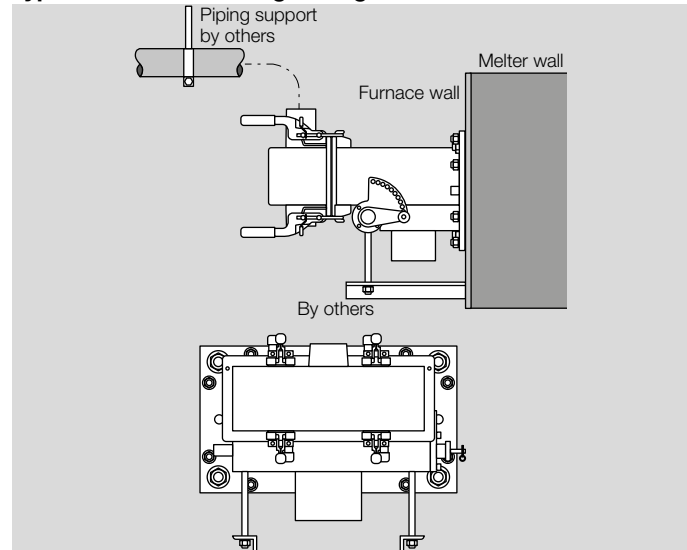

### Alternate burner mounting arrangement

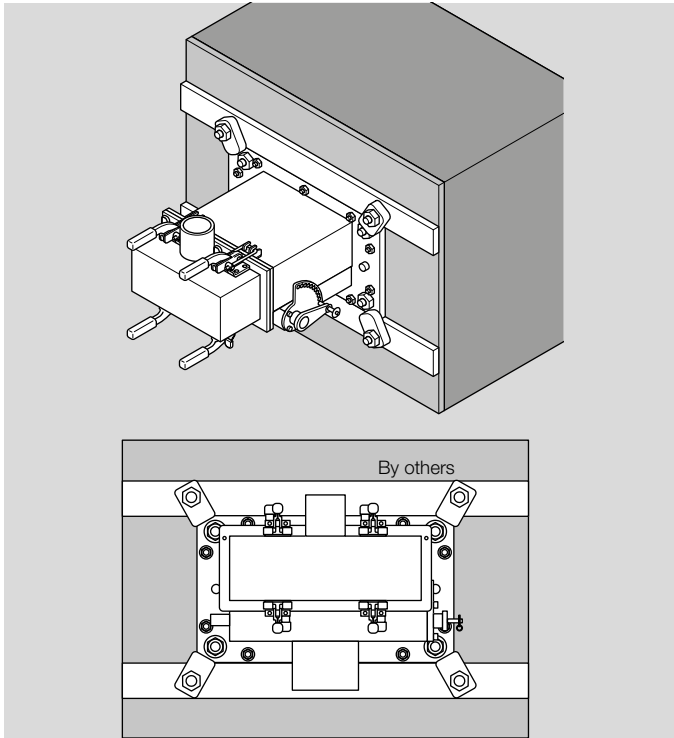

#### ⚠ CAUTION

For maximum burner life, burner housing and associated parts must be protected from hot gases.

- Burners should not be installed in a down-fired position.
- The primary objective is to seal the burner block in the wall of the furnace and support the weight of any system piping.
- The burner block sits on the sill or wall. The block must rest flat on the sill or wall without rocking to allow weight to be equally distributed. Failure to do so could result in cracking and/or block failure. If burner port holes are too large, appropriate material shims may be used to align the burner.
- Burner block failure could result from external forces and stresses transmitted to the burner through the piping. Under no circumstances should burner be the only support for the piping. Flexible connections are recommended in all piping to reduce piping stresses and alignment/shifting problems. Installation of such connectors at certain key spots in the oxygen or gas manifolding can prevent damage to the burners from uneven thermal expansion.
- The opening of the furnace wall should provide 1/16" clearance on all sides. High temperature furnace sealant or gasketing should be used between burner mounting flange and furnace wall.

### 4.4 Burner installation procedure

#### ⚠ CAUTION

Failure to follow the proper installation sequence noted below could result in damage or destruction of vital burner components. Cooling oxygen or air flows should be present at all times when the burner housing and metal components are mounted to a hot furnace.

- To prevent damage in transit, the fuel inserts, mounting gaskets and burner housing may be packed separately. In most cases, the burner will be shipped assembled but with the mounting nuts only finger-tight. In either case, the burner block and frame will need to be disassembled from the rest of the burner to allow installation of the block into the furnace wall.
- A 3/4" (12 mm) socket is required for mounting nuts. A manual speed wrench is recommended for quick and easy burner mounting.
- 1 If fuel insert is shipped inside burner housing, remove the fuel insert and insert nut and set aside in a protected area.

- 2 Install service plate over housing flange and secure plate to housing using T-bolts provided.
- 3 Pre-pipe quick-connect devices to the combustion oxygen, fuel and atomizing connections (if required) on the burner housing and burner fuel inserts.
- 4 Install block/plate/housing assembly into furnace wall.
- 5 Establish cooling flow of air or oxygen through the housing during furnace heat up.

#### ⚠ CAUTION

Staged oxygen control valve must be placed in position #1 as shown in next chapter.

### 4.5 Staging ratio control

OXYTHERM FHR burners feature an adjustable staged oxygen design to optimize heat transfer, flame volume and emissions. Increasing the staged oxygen produces higher radiative heat flux, larger flame volume and lower NO<sub>x</sub> emissions; decreasing staged oxygen produces lower radiative heat flux, smaller flame volume and higher NO<sub>x</sub> emissions. The numbered hole positions (1-11) shown on the drawing below correspond with the hole positions indicated on the primary/staged oxygen valve adjustment graphs available from your Honeywell Maxon sales representative.

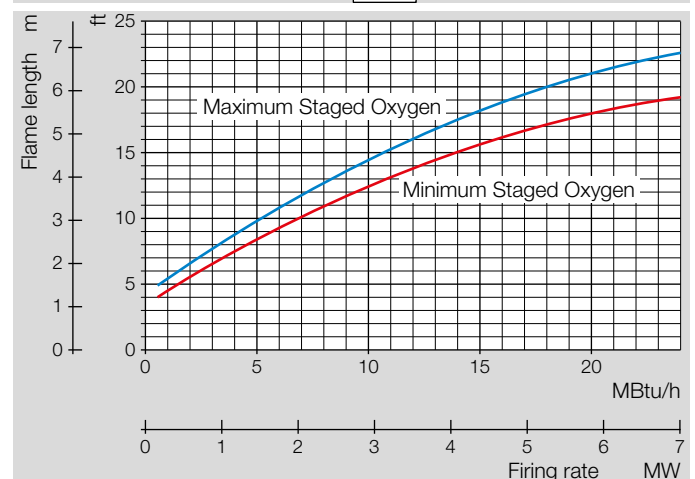
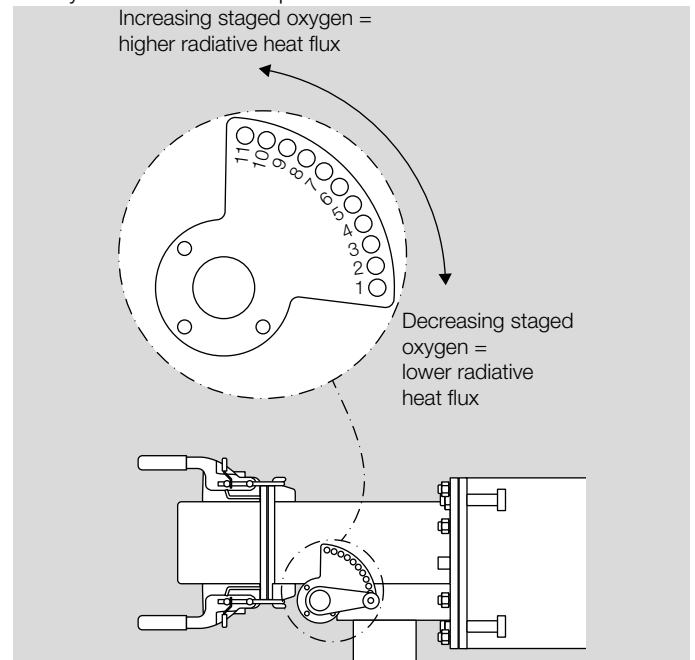

Flame lengths shown are typical for burners sized and operating at maximum design conditions. Flame lengths per unit of heat input will vary from these values when burners are operated below maximum design.

## 5 COMMISSIONING

### ⚠ CAUTION

- Read the combustion system manual carefully before initiating the start-up and adjustment procedure.
- Verify that all of the equipment associated with and necessary to the safe operation of the burner system has been installed correctly.
- Verify that all pre-commissioning checks have been carried out successfully and that all safety related aspects of the installation are properly addressed.

#### 5.1 Start-up

- OXY-THERM FHR burners do not include means for self ignition. Burner ignition procedure is the responsibility of the end user, according to applicable local, state and national codes. Burner ignition should only be attempted at minimum firing rates (see capacity charts or contact Honeywell Maxon) to prevent pressure surge in the fired chamber.

#### 5.2 Checks during and after start-up

- During and after start-up, check the integrity of the system. Check all bolted connections after first firing (first time on temperature) and retighten if necessary.

#### 5.3 Burner adjustment and control

### ⚠ CAUTION

Oxygen should only be used with approved materials, properly cleaned pipe and equipment, and specially designed systems. Ordinary materials can be extremely flammable in the presence of oxygen and air enriched with oxygen.

- Oxygen-fuel burners require accurate control of both fuel and oxygen for optimum performance. Piping to individual burners should include control valves for both oxygen and fuel. In addition, flow meters for oxygen and fuel capable of local or remote readout are required for proper burner adjustment.
- Oxy-fuel burners cannot be set up and operated properly using only pressure requirements for adjustment. Fully metered oxygen and fuel control systems are required for safe and optimum performance.

## 6 MAINTENANCE

### ⚠ WARNING

The OXY-THERM FHR burner is provided with quick release clamps to allow for rapid changeover between gas and oil firing.

- Customer-specific procedures for shut down and blocking of fuel gas and oxygen supply to the burner must be developed and adhered to prior to attempting removal and changing of fuel inserts. Only trained and qualified service and maintenance personnel should perform this operation.

#### Safety requirements

- Regular inspection, testing and recalibration of combustion equipment according to the installation's manual are an integral part of its safety.
- Inspection activities and frequencies shall be carried out as specified in the installation's manual.
- Perform the following activities at least annually as part of a recommended preventative maintenance routine:
  - 1 Inspect burner internal parts for wear and oxidation, paying special attention to the refractory of the burner block (when applicable).
  - 2 Inspect associated control instruments and devices for function with particular attention to all safety permissive switches.
  - 3 Perform leak tests on fuel shut off valves according to any schedule established by the authority having jurisdiction.

#### Visual inspections

- Regular visual inspection of all connections (air and gas piping to the burner, bolting of the burner mounting flange) and burner flame shape and aspect are essential for safe operation.

#### 6.1 Spare parts

- Keep local stock of spark ignitor if burner is equipped with pilot. It is not recommended to keep local stock of other burner parts.
- A list of spare parts can be found at [www.partdetective.de](http://www.partdetective.de).

## 7 TECHNICAL DATA

### 7.1 OXY-THERM FHR gas burners

#### 7.1.1 Imperial burner data

Stated pressures are indicative. Actual pressures are a function of air humidity, altitude, type of fuel and gas quality.

Type	Maximum capacity range MBTU/h <sup>1)</sup>	Turndown
Small (S)	1.3–2.9	3:1
Medium (M)	2.9–5.7	3:1
Large (L)	6.0–12.0	3:1
Extra Large (X)	10.0–24.0	3:1

<sup>1)</sup> Capacities in BTU/h refer to the higher heating value HHV (gross calorific value).

### Natural gas/Propane

- Natural gas at 60 °F  
with 1000 BTU/ft<sup>3</sup> (st) HHV – sg = 0.6<sup>2)</sup>
- Propane at 60 °F  
with 2500 BTU/ft<sup>3</sup> HHV – sg = 1.57<sup>2)</sup>

Type	Pressures required to burner inlet for maximum capacities			Typical oxygen to fuel volumetric ratios	
	Oxygen (@ 50 % staged)	Natural gas	Propane	To natural gas	To propane
	psig	psig	psig		
Small (S)	< 1.0	1.2	2.5	2.05–1	5.1–1
Medium (M)	< 1.0	1.2	2.5	2.05–1	5.1–1
Large (L)	< 1.0	1.2	2.5	2.05–1	5.1–1
Extra Large (X)	< 1.4	1.2	2.5	2.05–1	5.1–1

### Natural gas/Propane mixed with Hydrogen

- 80 % Natural gas/20 % Hydrogen at 60 °F  
with 863 BTU/ft<sup>3</sup> (st) HHV – sg = 0.49<sup>2)</sup>
- 80 % Propane/20 % Hydrogen at 60 °F  
with 2070 BTU/ft<sup>3</sup> HHV – sg = 1.232<sup>2)</sup>

Type	Pressures required to burner inlet for maximum capacities			Typical oxygen to fuel volumetric ratios	
	Oxygen (@ 50 % staged)	80 % NG/20 % H <sub>2</sub>	80 % Propane/20 % H <sub>2</sub>	To 80 % NG/20 % H <sub>2</sub>	To 80 % Propane/20 % H <sub>2</sub>
	psig	psig	psig		
Small (S)	< 0.97	1.32	2.967	1.74–1	4.18–1
Medium (M)	< 0.97	1.32	2.967	1.74–1	4.18–1
Large (L)	< 0.97	1.32	2.967	1.74–1	4.18–1
Extra Large (X)	< 0.97	1.32	2.967	1.74–1	4.18–1

<sup>2)</sup> sg (specific gravity) = relative density to air (density air = 0.0763 lb/ft<sup>3</sup> (st))

Approximate flame size, see page 3 (4.5 Staging ratio control)

### 7.1.2 Metric burner data

Stated pressures are indicative. Actual pressures are a function of air humidity, altitude, type of fuel and gas quality.

Type	Maximum capacity range kW <sup>1)</sup>	Turndown
Small (S)	344–767	3:1
Medium (M)	767–1507	3:1
Large (L)	1586–3173	3:1
Extra Large (X)	2644–6346	3:1

<sup>1)</sup> Capacities in kW refer to the lower heating value LHV.

### Natural gas/Propane

- Natural gas at 15 °C  
with 10.9 kWh/m<sup>3</sup> (st) HHV – sg = 0.6<sup>2)</sup>
- Propane at 15 °C  
with 26.8 kWh/m<sup>3</sup> (st) HHV – sg = 1.57<sup>2)</sup>

Type	Pressures required to burner inlet for maximum capacities			Typical oxygen to fuel volumetric ratios	
	Oxygen (@ 50 % staged)	Natural gas	Propane	To natural gas	To propane
	mbar	mbar	mbar		
Small (S)	< 69	82	172	2.05–1	5.1–1
Medium (M)	< 69	82	172	2.05–1	5.1–1
Large (L)	< 69	82	172	2.05–1	5.1–1
Extra Large (X)	< 96	82	172	2.05–1	5.1–1

### Natural gas/Propane mixed with Hydrogen

- 80 % Natural gas/20 % Hydrogen at 15 °C  
with 8.933 kWh/m<sup>3</sup> (st) HHV – sg = 0.49<sup>2)</sup>

- 80 % Propane/20 % Hydrogen at 15 °C  
with 21.498 kWh/m<sup>3</sup> (st) HHV – sg = 1.232<sup>2)</sup>

Type	Pressures required to burner inlet for maximum capacities			Typical oxygen to fuel volumetric ratios	
	Oxygen (@ 50 % staged)	80 % NG/20 % H <sub>2</sub>	80 % Propane/20 % H <sub>2</sub>	To 80 % NG/20 % H <sub>2</sub>	To 80 % Propane/20 % H <sub>2</sub>
	mbar	mbar	mbar		
Small (S)	< 67	90	204	1.74–1	4.18–1
Medium (M)	< 67	90	204	1.74–1	4.18–1
Large (L)	< 67	90	204	1.74–1	4.18–1
Extra Large (X)	< 67	90	204	1.74–1	4.18–1

<sup>2)</sup> sg (specific gravity) = relative density to air (density air = 1.293 kg/Nm<sup>3</sup>) (st)

Approximate flame size, see page 3 (4.5 Staging ratio control)

## 7.2 OXY-THERM FHR oil burners

### 7.2.1 Imperial burner data

Fuel: LFO = Light Fuel Oil, HFO = Heavy Fuel Oil

Heavy fuel oils require heating to obtain proper viscosity (less than 100 SSU or 21 cs) for optimal atomization. Temperature of HFO should be measured at burner inlet, not HFO storage tank or oil heater outlet.

Type	Oil nozzle	Max. flow	Fuel oil pressure @ maximum		Turndown	Atomizing pressure		Flame length range @ maximum feet
			LFO	HFO		LFO	HFO	
			psig	psig		psig	psig	
OT FHR S O..41	115	10.8	75	95	3:1	60	80	4–5.5
OT FHR S O..58	125	15.4	75	95	3:1	60	80	4–5.5
OT FHR S O..68	156	17.9	75	95	3:1	60	80	4.5–6
OT FHR M O..99	188	26.2	75	95	3:1	60	80	5–6.5
OT FHR M O..134	218	35.3	75	95	3:1	60	80	5–6.5
OT FHR M O..193	250	50.9	75	95	3:1	60	80	8–10
OT FHR L O..217	281	57.4	75	95	3:1	60	80	10–12
OT FHR L O..251	312	66.4	75	95	3:1	60	80	10–12
OT FHR L O..313	328	82.7	75	95	3:1	60	80	11–13
OT FHR L O..358	344	94.6	75	95	3:1	60	80	12–14
OT FHR XL O..462	391	122.2	75	95	3:1	60	80	13–15
OT FHR XL O..500	422	132.2	75	95	3:1	60	80	14–16
OT FHR XL O..569	438	150.3	75	95	3:1	60	80	15–17

Burner fuel oil insert and oil piping near the fuel inlet should be purged with compressed air after shut down to clear any remaining fuel oil. Failure to do so may cause plugging of oil atomizer and nozzle, and cause poor or improper performance.

### 7.2.2 Metric burner data

Fuel: LFO = Light Fuel Oil, HFO = Heavy Fuel Oil

Heavy fuel oils require heating to obtain proper viscosity (less than 100 SSU or 21 cs) for optimal atomization. Temperature of HFO should be measured at burner inlet, not HFO storage tank or oil heater outlet.

Type	Oil nozzle	Max. flow	Fuel oil pressure @ maximum		Turndown	Atomizing pressure		Flame length range @ maximum m
			LFO	HFO		LFO	HFO	
			mbar	mbar		mbar	mbar	
OT FHR S O..41	115	41	5171	6550	3:1	4137	5515	1.2–1.7

Type	Oil nozzle	Max. flow	Fuel oil pressure @ maximum		Turndown	Atomizing pressure		Flame length range @ maximum
			LFO	HFO		LFO	HFO	
			liters/h	mbar		mbar	mbar	mbar
OT FHR S O..58	125	58	5171	6550	3:1	4137	5515	1.2–1.7
OT FHR S O..68	156	68	5171	6550	3:1	4137	5515	1.4–1.8
OT FHR M O..99	188	99	5171	6550	3:1	4137	5515	1.5–2
OT FHR M O..134	218	134	5171	6550	3:1	4137	5515	1.5–2
OT FHR M O..193	250	193	5171	6550	3:1	4137	5515	2.4–3
OT FHR L O..217	281	217	5171	6550	3:1	4137	5515	3–3.7
OT FHR L O..251	312	251	5171	6550	3:1	4137	5515	3–3.7
OT FHR L O..313	328	313	5171	6550	3:1	4137	5515	3.3–4
OT FHR L O..358	344	358	5171	6550	3:1	4137	5515	3.7–4.3
OT FHR XL O..462	391	462	5171	6550	3:1	4137	5515	4–4.6
OT FHR XL O..500	422	500	5171	6550	3:1	4137	5515	4.3–4.9
OT FHR XL O..569	438	569	5171	6550	3:1	4137	5515	4.6–5.2

Burner fuel oil insert and oil piping near the fuel inlet should be purged with compressed air after shut down to clear any remaining fuel oil. Failure to do so may cause plugging of oil atomizer and nozzle, and cause poor or improper performance.

## 8 DISPOSAL

Devices with electronic components:

### WEEE Directive 2012/19/EU – Waste Electrical and Electronic Equipment Directive



At the end of the product life (number of operating cycles reached), dispose of the packaging and product in a corresponding recycling centre. Do not dispose of the unit with the usual domestic refuse. Do not burn the product. On request, old units may be returned carriage paid to the manufacturer in accordance with the relevant waste legislation requirements.

## FOR MORE INFORMATION

The Honeywell Thermal Solutions family of products includes Honeywell Combustion Safety, Eclipse, Exothermics, Hauck, Kromschröder and Maxon. To learn more about our products, visit [ThermalSolutions.honeywell.com](https://ThermalSolutions.honeywell.com) or contact your Honeywell Sales Engineer.  
Honeywell MAXON branded products  
201 E 18th Street  
Muncie, IN 47302  
USA  
[ThermalSolutions.honeywell.com](https://ThermalSolutions.honeywell.com)

© 2022 Honeywell International Inc.

