

Flow meters DM, DE

TECHNICAL INFORMATION

- Flow meters for gas with short, compact aluminium housing
- Measurement of the current flow rate (DE) and the quantity consumed (DM, DE)
- M-BUS interface (DE)
- Large measuring range
- Little servicing required
- EC-type tested and certified



Contents

Contents	2
1 Application	3
2 Certification	5
3 Function	6
3.1 DM	6
3.2 DE	7
4 Flow rate	8
5 Selection	10
5.1 DM selection table	10
5.2 DM type code	10
5.3 DM..T selection table	11
5.4 DM..T type code	11
5.5 DE selection table	12
5.6 DE type code	12
5.7 DE..T selection table	13
5.8 DE..T type code	13
6 Project planning information	14
6.1 Installation	14
6.2 Flow rate at standard conditions/Operating flow rate	14
6.3 Positive tolerance	15
6.4 DM in potentially explosive atmospheres	15
6.5 Connection of pulse generators	15
7 Technical data	16
7.1 DM	16
7.2 DE	17
7.3 Dimensions	19
7.3.1 DM [mm]	19
7.3.2 DM [inch]	21
7.3.3 DE [mm]	23
7.3.4 DE [inch]	25
Fore more information	27

1 Application

Flow meters DM and DE measure the gas and air volumes on consumer equipment. They are typically used for the internal billing of consumption in industrial installations, laboratories and test rigs, and in particular for checking and adjusting burners in gas-using equipment. The gas flow rate can be checked in production and heating processes, thus allowing energy utilization to be optimized.

DM

Flow meter DM is equipped with a 7-digit mechanical index and can be used in potentially explosive atmospheres.



DM in threaded version



DM in intermediate flange version

Application

DE

Flow meter DE has an electronic index and is equipped with a 7-digit LCD display. Various recorded values can be retrieved, e.g. the current flow rate.

The DE is also equipped with M-BUS interfaces. In addition, it is compatible with the optical interface ZVEI.

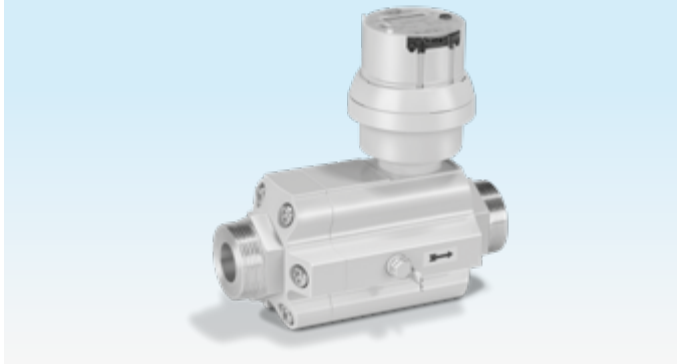

DE in threaded version

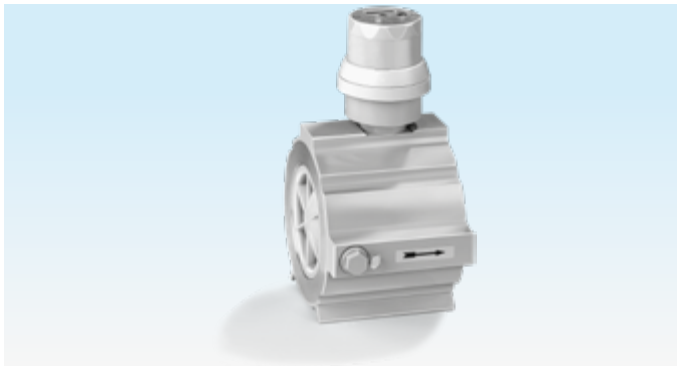

DE in intermediate flange version

2 Certification

Certificates – see www.docuthek.com.

EU certified



DM

Complies with the following Directives

- Pressure equipment (2014/68/EU)
- Equipment for use in potentially explosive atmospheres (2014/34/EU)

in conjunction with standards

- EN 12261:2002 * AI:2006 (PED)
- EN 13463-1:2009 (ATEX)
- EN 13463-5:2011 (ATEX)

DE

Complies with Directive

- Pressure equipment (2014/68/EU)

in conjunction with standard

- EN 12261:2002 * AI:2006 (PED)

3 Function

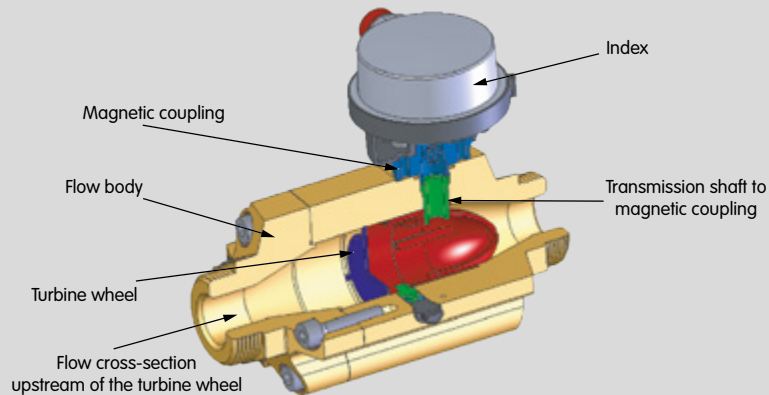

Flow meters DM and DE are identical as regards their flow behaviour and basic design. The flow volume drives a turbine wheel. A magnetic coupling is used to transfer the rotary movement of the turbine wheel to the index. The rotational speed of the turbine wheel is proportional to the flow rate of the medium flowing through the meter.

3.1 DM

Flow meter DM has a mechanical index on which the operating volume [m³(b)] consumed is totalized and displayed.



A remote indicator can be operated using two integrated pulse generators, see page 16 (Technical data). These two pulse generators are an E1 reed contact and an E200 inductive generator in accordance with DIN EN 50227 (Namur).

3.2 DE

On flow meter DE, the flow rate is recorded by an electronic index. It can be equipped with an M-BUS interface to allow transfer of meter readings to a PC. Consumption and flow data can thus be processed and archived consistently.

In addition, the DE is equipped with a pulse generator (E200, Namur) for remote indication of the quantity consumed, see page 16 (Technical data).

In default mode, the 7-digit LCD display on the electronic index shows the cumulative operating volume consumed [$\text{m}^3(\text{b})$].

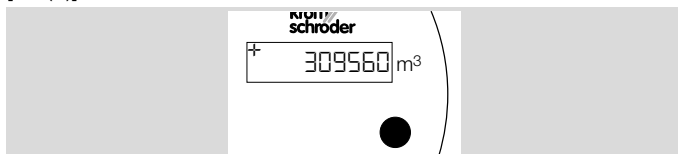

From here, different values can be called up using a control button on the index:

Key-date value

The key-date value [m^3/a] indicates the consumption through to the last key date. The key-date value function stores the total consumption figures once per year (on the key date). This function allows you to determine the consumption in the current year at any time.

High resolution of the total consumption [m^3]

High resolution of the total consumption means that the quantity consumed [m^3] is displayed to three places after the decimal point.

Current operating flow rate [$\text{m}^3/\text{h}(\text{b})$]

The current flow rate [m^3/h] is recorded here.

Key date

Key date indicates the date on which the total consumption is saved in the key-date value, e.g. 31.12.12. Key date and key-date volume [m^3/a] are displayed alternately.

Reverse flow volume [m^3]

Flow meter DE can record a flow rate in both directions. The cumulative reverse flow volume is displayed in this program option.

4 Flow rate

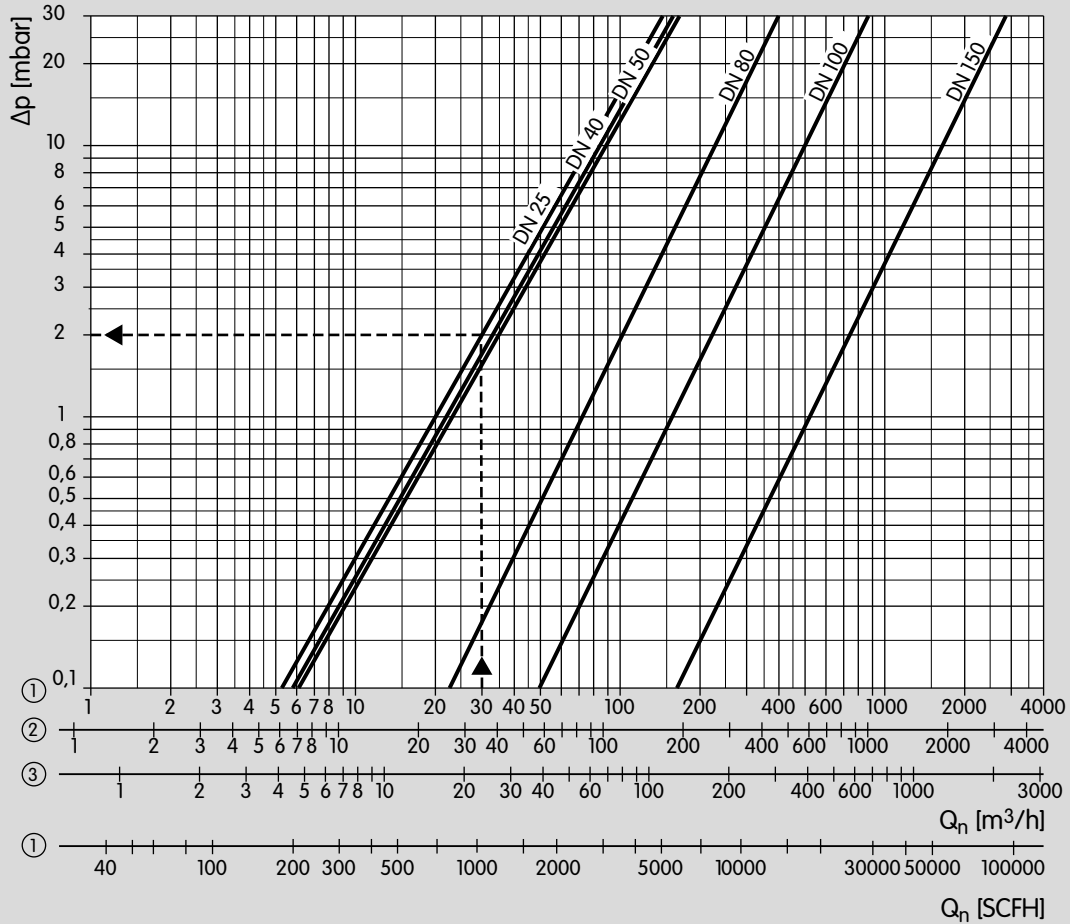

- 1 = natural gas ($\rho = 0.80 \text{ kg/m}^3$)
- 2 = town gas ($\rho = 0.58 \text{ kg/m}^3$)
- 3 = air ($\rho = 1.29 \text{ kg/m}^3$)

When reading off the values, operating cubic metres must be used. Then the pressure loss Δp read must be multiplied

Flow rate

by the absolute inlet pressure p_U in bar (positive pressure + 1) to account for the change in the medium's density.

Example:

Flow rate $Q = 30 \text{ m}^3/\text{h}$

Gas type: natural gas

Inlet pressure $p_U = 4 \text{ bar}$

$30 \text{ m}^3/\text{h} \rightarrow \text{DN } 25 \rightarrow 2 \text{ mbar}$

$\Delta p = 2 \times (4 + 1) = 10 \text{ mbar}$ on the flow meter

5 Selection

Scope of delivery for DM, DE:

1 × calibration certificate (with 3 measuring points for $Q_{\min.}$, $0.5 \times Q_{\max.}$, $Q_{\max.}$),

1× acceptance report to EN 10204.

5.1 DM selection table

Option	DM 10	DM 16	DM 25	DM 40	DM 65	DM 100	DM 160	DM 250	DM 400	DM 650	DM 1000
Installation	R	R	R	R	Z	Z	Z	Z	Z	Z	Z
Nominal size DN	25	25	25	25, 40	50	80	80	100	100, 150	150	150
Inlet pressure	-40, 160	-40, 160	-40, 160	-40, 160	-40, 160	-40, 160	-40, 160	-40, 160	-40, 160	-40, 160	-40, 160

Order example

DM 16R25-40

5.2 DM type code

Code	Description
DM	Mechanical index
10-1000	Nominal flow rate [m ³ /h]
R* Z	Rp internal thread For fitting between two DIN flanges
25-150	Nominal size
-40 -160	Max. inlet pressure p_U : 4 bar Max. inlet pressure p_U : 16 bar

* DM..R can be used for internal and external thread connection. Cap screws for internal threads are included in the delivery.

5.3 DM..T selection table

Option	DM 16	DM 25	DM 40	DM 65	DM 100	DM 160	DM 250	DM 400
T-product	T	T	T	T	T	T	T	T
Installation	N	N	N	W	W	W	W	W
Nominal size DN	25	25	25, 40	50	80	80	100	100
Inlet pressure	-120	-120	-120	-120	-120	-120	-120	-120

Order example

DM 16TN25-120

5.4 DM..T type code

Code	Description
DM	Mechanical index
16-400	Nominal flow rate [m ³ /h]
T	T-product
N* W	NPT internal thread For fitting between two ANSI flanges
25-100	Nominal size
-120	Max. inlet pressure $p_{U,max.}$: 12 bar (175 psig)

* DM..N be used for internal and external thread connection. Cap screws for internal threads are included in the delivery.

5.5 DE selection table

Option	DE 10	DE 16	DE 25	DE 40	DE 65	DE 100	DE 160	DE 250	DE 400	DE 650	DE 1000
Installation	R	R	R	R	Z	Z	Z	Z	Z	Z	Z
Nominal size DN	25	25	25	25, 40	50	80	80	100	100, 150	150	150
Inlet pressure	-40, -160	-40, -160	-40, -160	-40, -160	-40, -160	-40, -160	-40, -160	-40, -160	-40, -160	-40, -160	-40, -160
Interface	B	B	B	B	B	B	B	B	B	B	B

Order example

DE 250Z100-160B

5.6 DE type code

Code	Description
DE	Electronic index
10-1000	Nominal flow rate [m ³ /h]
R* Z	Rp internal thread For fitting between two DIN flanges
25-150	Nominal size
-40 -160	Max. inlet pressure p _U : 4 bar Max. inlet pressure p _U : 16 bar
B	M-BUS interface

* DE..R can be used for internal and external thread connection. Cap screws for internal threads are included in the delivery.

5.7 DE..T selection table

Option	DE 16	DE 25	DE 40	DE 65	DE 100	DE 160	DE 250	DE 400	DE 650
T-product	T	T	T	T	T	T	T	T	T
Installation	N	N	N	W	W	W	W	W	W
Nominal size DN	25	25	25, 40	50	80	80	100	100, 150	150
Inlet pressure	-120	-120	-120	-120	-120	-120	-120	-120	-120
Interface	B	B	B	B	B	B	B	B	B

Order example

DE 250TW100-120B

5.8 DE..T type code

Code	Description
DE	Electronic index
16-650	Nominal flow rate [m ³ /h]
T	T-product
N* W	NPT internal thread For fitting between two ANSI flanges
25-150	Nominal size
-120	Max. inlet pressure $p_{u \max.}$: 12 bar (175 psig)
B	M-BUS interface

* DE..N be used for internal and external thread connection. Cap screws for internal threads are included in the delivery.

6 Project planning information

6.1 Installation

The unit may only be installed in the vertical or horizontal position, not upside down.

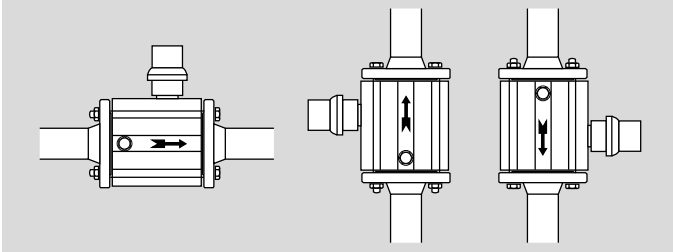

Flow meters in the threaded version and with an E200 pulse output can be used for flow control. For this application, the DM/DE..R must be installed in the horizontal position with the index facing upwards.

The flow meter must be installed with the direction of flow from bottom to top for gases loaded with condensation. In this case, a condensate drain must also be installed.

If the flowing gas is contaminated by foreign bodies or dust, and/or when measuring the surrounding air, we recommend installing a filter in the upstream pipe. When designing new systems, a strainer (mesh size 0.5 mm (0.0197")) should be fitted immediately upstream of the meter to protect it from foreign bodies such as metal chips. The strainer can be removed after 4 weeks at the latest.

In addition, we recommend installing a shut-off valve upstream and downstream of the flow meter.

It is important to note that the flow meter should not be installed at the lowest point of the pipe if the flowing gas is contaminated by condensation or dirt.

The flow meters must be fitted in a straight pipe with a length of 3 x DN upstream of the meter and an outlet section of 2 x DN downstream of the meter in order to achieve maximum measurement accuracy.

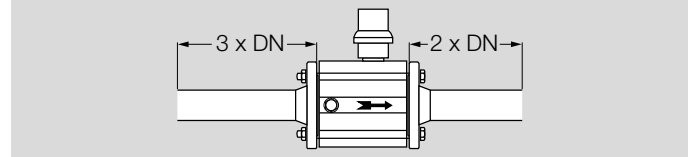

The pipe downstream of the flow meter must not have any restriction point which could cause the flow to back up. All approved flat seal types may be used.

The service life and measurement accuracy can be adversely affected by permanently high temperatures as well as by operation subjected to shocks, impulses and vibrations.

6.2 Flow rate at standard conditions/ Operating flow rate

The flow rate Q is displayed in operating cubic metres (Q_b [$m^3(b)$]). For approximate conversion to standard cubic metres (Q_n [$m^3(n)$]),

the absolute pressure ($p_b = p_u + 1.013$ bar)
and absolute temperature ($T_b = \vartheta_b + 273$ K)
at the metering point must be known.

$$Q_n = Q_b \times \frac{p_b}{T_b} \times \frac{273}{1,013}$$

$$Q_n = Q_b \times \frac{p_u + 1,013}{\vartheta_b + 273} \times \frac{273}{1,013}$$

Example

Flow rate Q_b read off: 20.7 m³/h

Inlet pressure p_u : 2 bar

Temperature ϑ_b : 20°C

$$Q_n = 20,7 \times \frac{2 + 1,013}{20 + 273} \times \frac{273}{1,013} = 57,4 \text{ m}^3/\text{h}$$

6.3 Positive tolerance

If flow rates Q change quickly, a considerable measurement error (positive tolerance) can occur due to over-run of the turbine wheel. In this case, a meter which uses a different measuring method should be installed, e.g. an ultrasonic meter, a diaphragm meter or a rotary gas meter.

Max. indicating error relating to the actual flow rate at constant flow

0.1 $Q_{\max.}$ to 0.2 $Q_{\max.}$	$\pm 3\%$ (DM, DE 10 $\pm 6\%$)
0.2 $Q_{\max.}$ to $Q_{\max.}$	$\pm 1.5\%$

6.4 DM in potentially explosive atmospheres

Flow meter DM can be installed in Category 2 (Zone 1) explosion-hazard areas. Only design-approved electrical operating equipment may be used for this.

6.5 Connection of pulse generators

When using pulse generator E1 (reed contact) or E200 (Namur), a screened cable must be used, e.g. LiYCY, 2 x 0.75 mm².

7 Technical data

7.1 DM

Display: 7-digit display with a resolution of 0.01 m³ for DN 25 and 0.1 m³ for DN 40–150.

Gas type: natural gas, town gas, air or inert gases. Also suitable for gaseous LPG.

Inlet pressure p_U :

DM..-40 for gas and air: max. 4 bar (1575 "WC),

DM..-160 for inert gases and air: max. 16 bar (6299 "WC),

DM..Z for gas: max. 16 bar (6299 "WC).

Ambient temperature: -10 to +60°C (14 to 140°F).

Housing: aluminium.

Enclosure: IP 52.

Plug for pulse generator

Threaded coupling; solder tag connection.

Enclosure: IP 30.

Pulse generator E1, reed contact

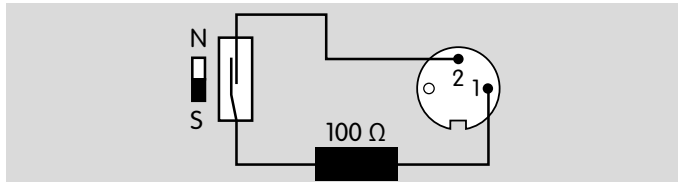

Max. switching voltage: $U_{max.} = 24 \text{ V}$,

max. switching current: $I_{max.} = 50 \text{ mA}$,

max. switching capacity: $P_{max.} = 0.25 \text{ W/VA}$,

contact resistance: $R_V = 100 \Omega \pm 20\%$.

The contact closes once for every revolution of the last digit roller.

Pulse generator E200 to DIN EN 50227 (Namur), inductive generator

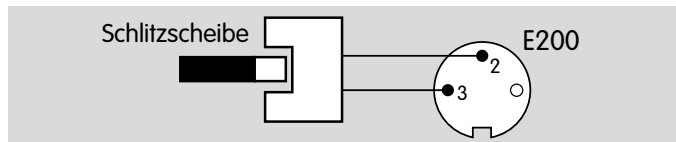

Supply voltage: $U_n = 8 \text{ V DC}$,
internal resistance: $R_i = 1 \text{ k}\Omega$.

The pulse is created by changing the current consumption from $I \leq 1 \text{ mA}$ to $I \geq 3 \text{ mA}$.

Type	Operating flow rate Q_b [m ³ /h]		Output pulse value [pul/m ³]	
	$Q_{min.}$	$Q_{max.}$	E200	E1
DM 10R25	1.6	16	500	10
DM 16R25	2.0	25	500	10
DM 25R25	2.5	40	500	10
DM 40R25	3.3	65	500	10
DM 40R40	5.0	65	250	1
DM 65Z50	6.0	100	250	1
DM 100Z80	10	160	187.5	1
DM 160Z80	13	250	187.5	1
DM 250Z100	20	400	187.5	1
DM 400Z100	32	650	187.5	1
DM 400Z150	32	650	187.5	1
DM 650Z150	50	1000	187.5	1
DM 1000Z150	80	1600	187.5	1

Type	Operating flow rate Q_b [SCFH]		Output pulse value [pul/ft ³]	
	$Q_{min.}$	$Q_{max.}$	E200	E1
DM 16N25	70.62	882.77	50	1
DM 25N25	88.28	1412.4	50	1
DM 40N25	116.53	2295.2	50	1
DM 40N40	176.55	2295.2	25	0.1
DM 65W50	211.86	3531.1	25	0.1
DM 100W80	353.11	5649.7	2.5	0.01
DM 160W80	459.04	8827.7	2.5	0.01
DM 250W100	706.21	14124	2.5	0.01
DM 400W100	1129.9	22952	2.5	0.01

7.2 DE

Display: 6-digit LCD display with a maximum resolution of 0.001 m³.

Gas type: natural gas, town gas, air or inert gases. Also suitable for gaseous LPG.

Inlet pressure p_u :

DE..-40 for gas and air: max. 4 bar (1575 "WC),

DE..-160 for inert gases and air: max. 16 bar (6299 "WC),

DE..Z for gas: max. 16 bar (6299 "WC).

Ambient temperature: 0 to +50°C (32 to 122°F).

Housing: aluminium.

Enclosure: IP 44.

M-BUS

Battery service life: approx. 8 years. The values which have been saved will be lost when the battery is changed.

Plug for pulse generator

Threaded coupling; solder tag connection.

Enclosure: IP 30.

Pulse generator E200 to DIN EN 50227 (Namur)

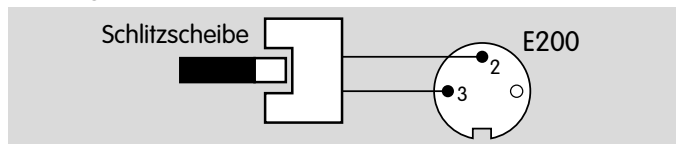

Supply voltage: $U_n = 8$ V DC, internal resistance: $R_i = 1$ k Ω .

The pulse is created by changing the current consumption from $I \leq 1$ mA to $I \geq 3$ mA.

Type	Operating flow rate Q_b [m ³ /h]		Output pulse value [pul/m ³]
	Q	Q	
DE 10R25	1.6	16	500
DE 16R25	2.0	25	500
DE 25R25	2.5	40	500
DE 40R25	3.3	65	500
DE 40R40	5.0	65	250
DE 65Z50	6.0	100	250
DE 100Z80	10	160	187.5
DE 160Z80	13	250	187.5
DE 250Z100	20	400	187.5
DE 400Z100	32	650	187.5
DE 400Z150	32	650	187.5
DE 650Z150	50	1000	187.5
DE 1000Z150	80	1600	187.5

Technical data

Type	Operating flow rate Q_b [SCFH]		Output pulse value [pul/ ft ³]
	Q	Q	
DE 16N25	70.62	882.77	14.2
DE 25N25	88.28	1412.4	14.2
DE 40N25	116.53	2295.2	14.2
DE 40N40	176.55	2295.2	7.1
DE 65W50	211.86	3531.1	7.1
DE 100W80	353.11	5649.7	5.3
DE 160W80	459.04	8827.7	5.3
DE 250W100	706.21	14124	5.3
DE 400W100	1129.9	22952	5.3
DE 400W150	1129.9	22952	5.3
DE 650W150	1765.5	35311	5.3

7.3 Dimensions

7.3.1 DM [mm]

DM..R

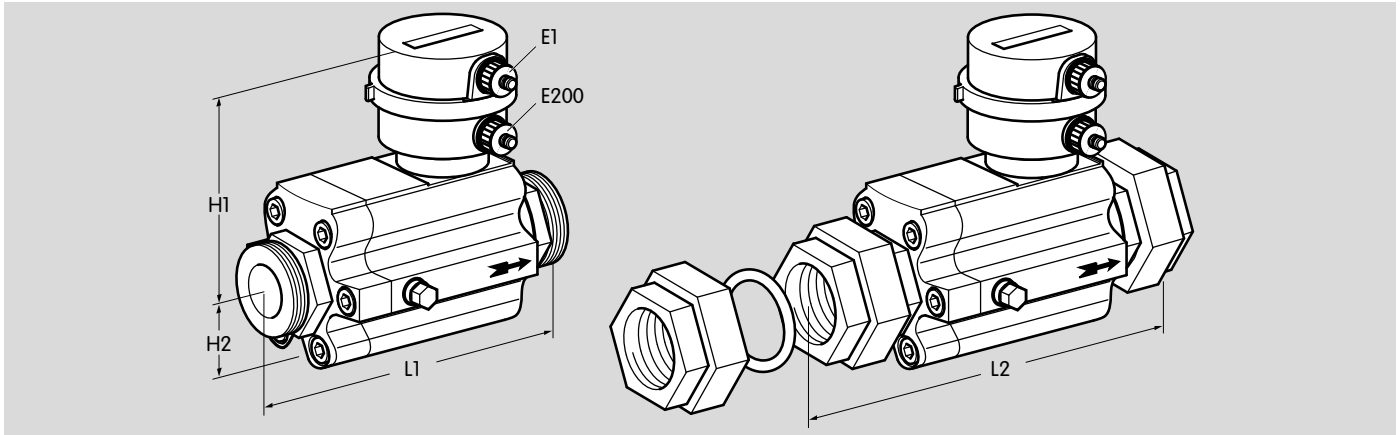

Type	DN	Connection	L1 [mm]	L2 [mm]	H1 [mm]	H2 [mm]	Weight kg
DM 10R25	25	Rp 1	185	240	115	44	2.1
DM 16R25	25	Rp 1	185	240	115	44	2.1
DM 25R25	25	Rp 1	185	240	115	44	2.1
DM 40R25	25	Rp 1	185	240	115	44	2.1
DM 40R40	40	Rp 1 1/2	126.5	190	150	52	2.5

DM..Z

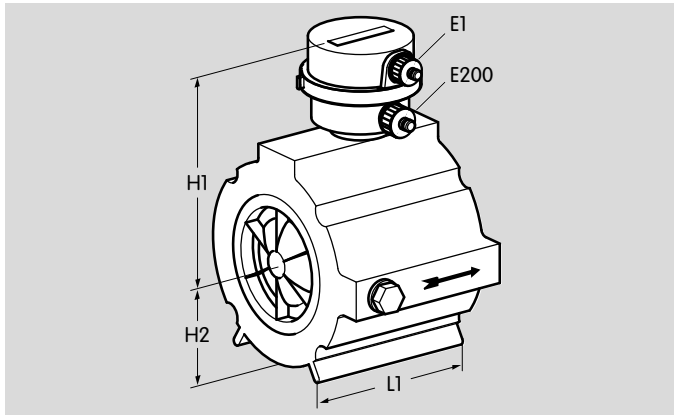

Type	DN	Connection	L1 [mm]	L2 [mm]	H1 [mm]	H2 [mm]	Weight kg
DM 65Z50	50	50	60	–	150	52	1.6
DM 100Z80	80	80	120	–	150	75	4.5
DM 160Z80	80	80	120	–	150	75	4.5
DM 250Z100	100	100	150	–	165	80	6.5
DM 400Z100	100	100	150	–	165	80	6.5
DM 400Z150	150	150	180	–	190	110	11.2
DM 650Z150	150	150	180	–	190	110	11.2
DM 1000Z150	150	150	180	–	190	110	11.2

7.3.2 DM [inch]

DM..N

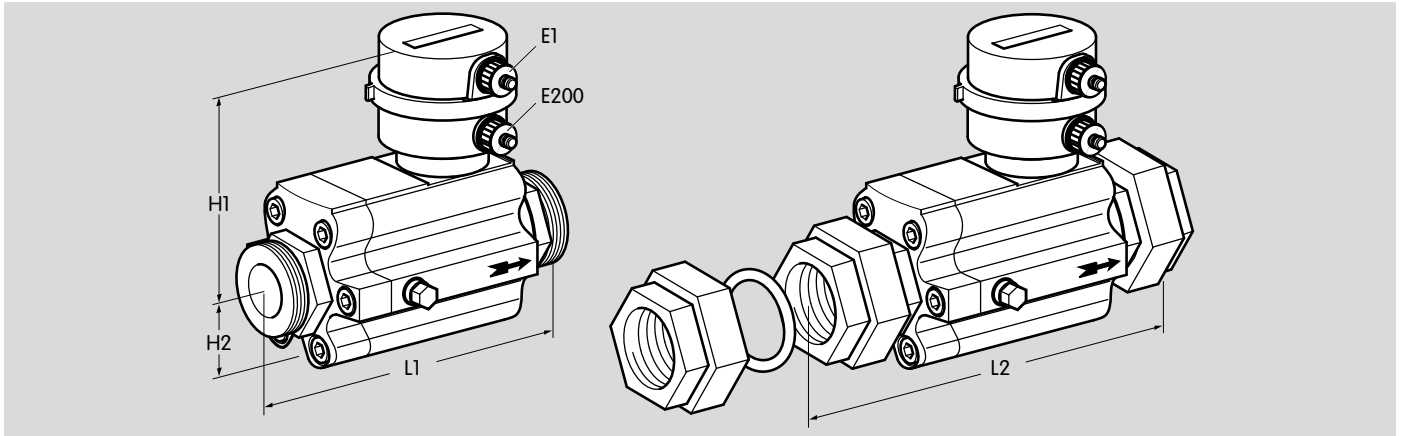

Type	DN	Connection	L1 [inch]	L2 [inch]	H1 [inch]	H2 [inch]	Weight lbs
DM 16TN25-120	25	1 NPT	7.28	9.45	4.53	1.73	4.6
DM 25TN25-120	25	1 NPT	7.28	9.45	4.53	1.73	4.6
DM 40TN25-120	25	1 NPT	7.28	9.45	4.53	1.73	4.6
DM 40TN40-120	40	1 ½ NPT	5	7.48	5.91	2.05	5.5

DM..W

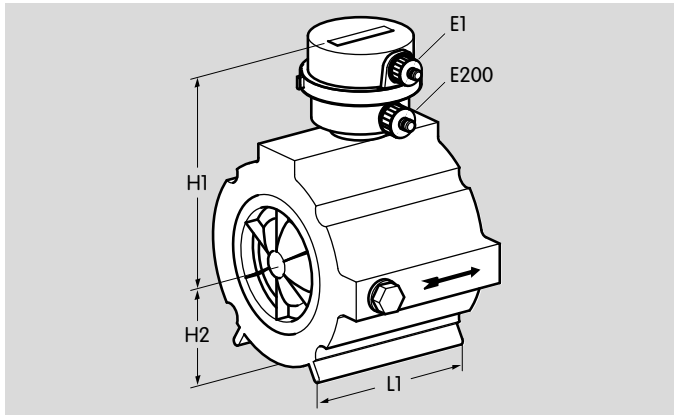

Type	DN	Connection	L1 [inch]	L2 [inch]	H1 [inch]	H2 [inch]	Weight lbs
DM 65TW50-120	50	2 FLG	2.36	–	5.91	2.05	3.5
DM 100TW80-120	80	3 FLG	4.72	–	5.91	2.95	10
DM 160TW80-120	80	3 FLG	4.72	–	5.91	2.95	10
DM 250TW100-120	100	4 FLG	5.91	–	6.5	3.15	14.3
DM 400TW100-120	100	4 FLG	5.91	–	6.5	3.15	14.3

7.3.3 DE [mm]

DE..R

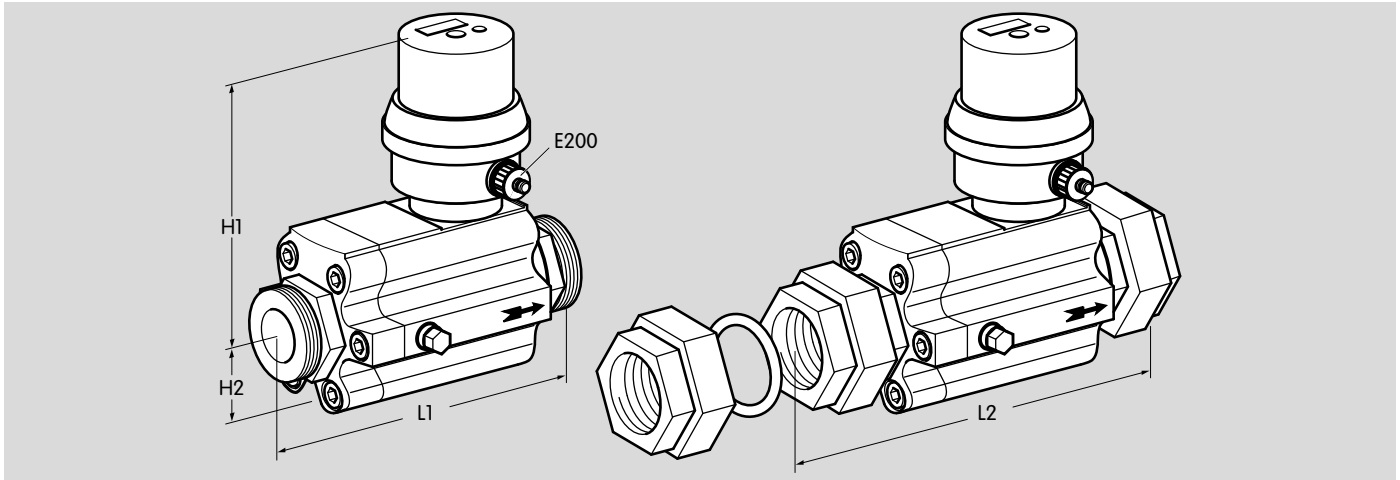

Type	DN	Connection	L1 [mm]	L2 [mm]	H1 [mm]	H2 [mm]	Weight kg
DE 10R25	25	Rp 1	185	240	140	44	2.1
DE 16R25	25	Rp 1	185	240	140	44	2.1
DE 25R25	25	Rp 1	185	240	140	44	2.1
DE 40R25	25	Rp 1	185	240	140	44	2.1
DE 40R40	40	Rp 1 ½	126.5	190	175	52	2.5

DE..Z

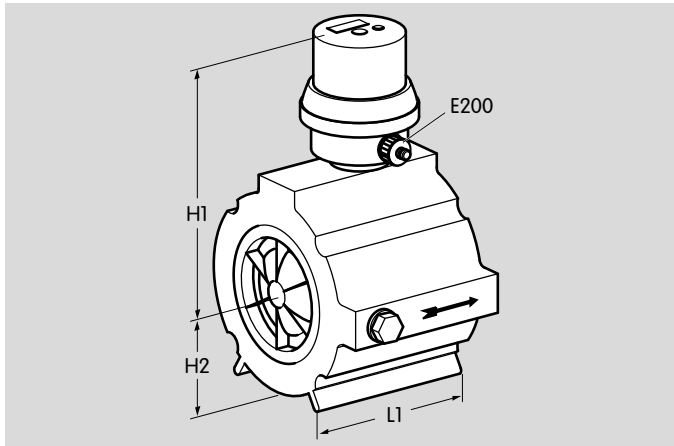

Type	DN	Connection	L1 [mm]	L2 [mm]	H1 [mm]	H2 [mm]	Weight kg
DE 65Z50	50	50	60	–	175	52	1.6
DE 100Z80	80	80	120	–	175	75	4.5
DE 160Z80	80	80	120	–	175	75	4.5
DE 250Z100	100	100	150	–	190	80	6.5
DE 400Z100	100	100	150	–	190	80	6.5
DE 400Z150	150	150	180	–	215	110	11.2
DE 650Z150	150	150	180	–	215	110	11.2
DE 1000Z150	150	150	180	–	215	110	11.2

7.3.4 DE [inch]

DE..N

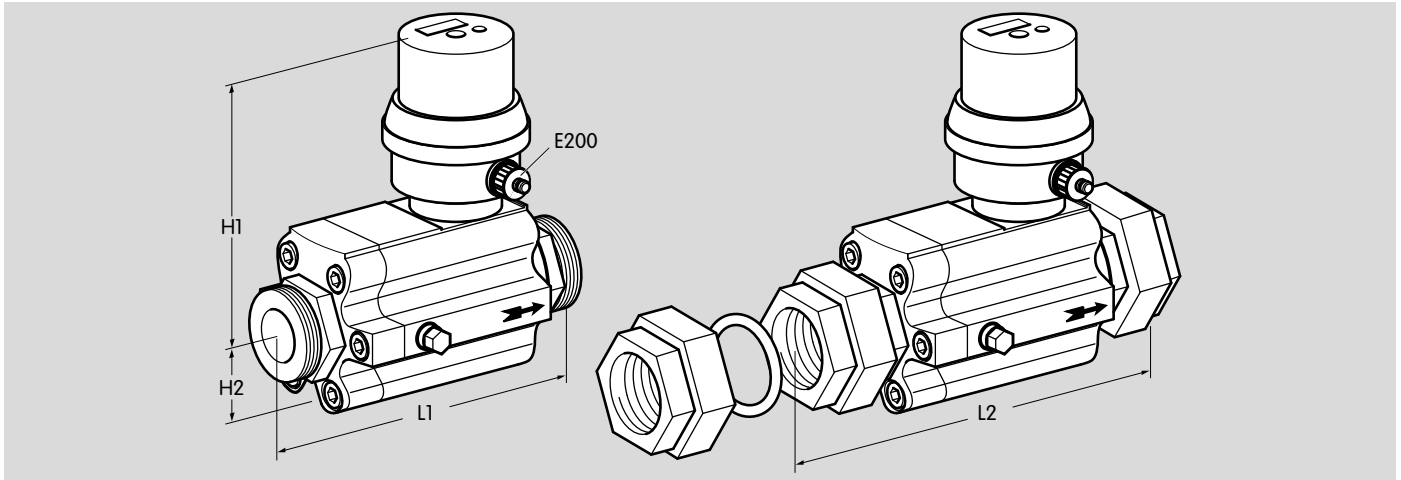

Type	DN	Connection	L1 [inch]	L2 [inch]	H1 [inch]	H2 [inch]	Weight lbs
DE 16TN25-120	25	1 NPT	7.28	9.45	5.5	1.73	4.6
DE 25TN25-120	25	1 NPT	7.28	9.45	5.5	1.73	4.6
DE 40TN25-120	25	1 NPT	7.28	9.45	5.5	1.73	4.6
DE 40TN40-120	40	1 1/2 NPT	5	7.48	6.9	2.05	5.5

DE..W

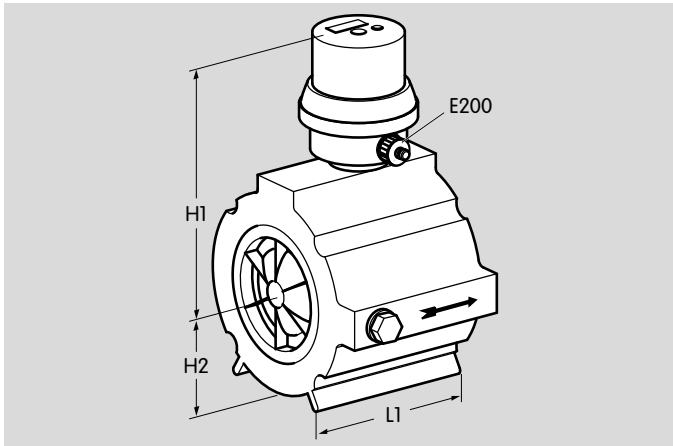

Type	DN	Connection	L1 [inch]	L2 [inch]	H1 [inch]	H2 [inch]	Weight lbs
DE 65TW50-120	50	2 FLG	2.36	–	6.9	2.05	3.5
DE 100TW80-120	80	3 FLG	4.72	–	6.9	2.95	10
DE 160TW80-120	80	3 FLG	4.72	–	6.9	2.95	10
DE 250TW100-120	100	4 FLG	5.91	–	6.9	3.15	14.3
DE 400TW100-120	100	4 FLG	5.91	–	6.9	3.15	14.3
DE 400TW150-120	150	6 FLG	7.1	–	8.46	4.33	24.6
DE 650TW150-120	150	6 FLG	7.1	–	8.46	4.33	24.6

Fore more information

The Honeywell Thermal Solutions family of products includes Honeywell Combustion Safety, Eclipse, Exothermics, Hauck, Kromschroder and Maxon. To learn more about our products, visit ThermalSolutions.honeywell.com or contact your Honeywell Sales Engineer.

Elster GmbH
Strotheweg 1, D-49504 Lotte
T +49 541 1214-0
hts.lotte@honeywell.com
www.kromschroeder.com

© 2020 Elster GmbH

We reserve the right to make technical modifications in the interests of progress.

