

# OPTIMA™ SLS

## Ultra Low Emissions Burner

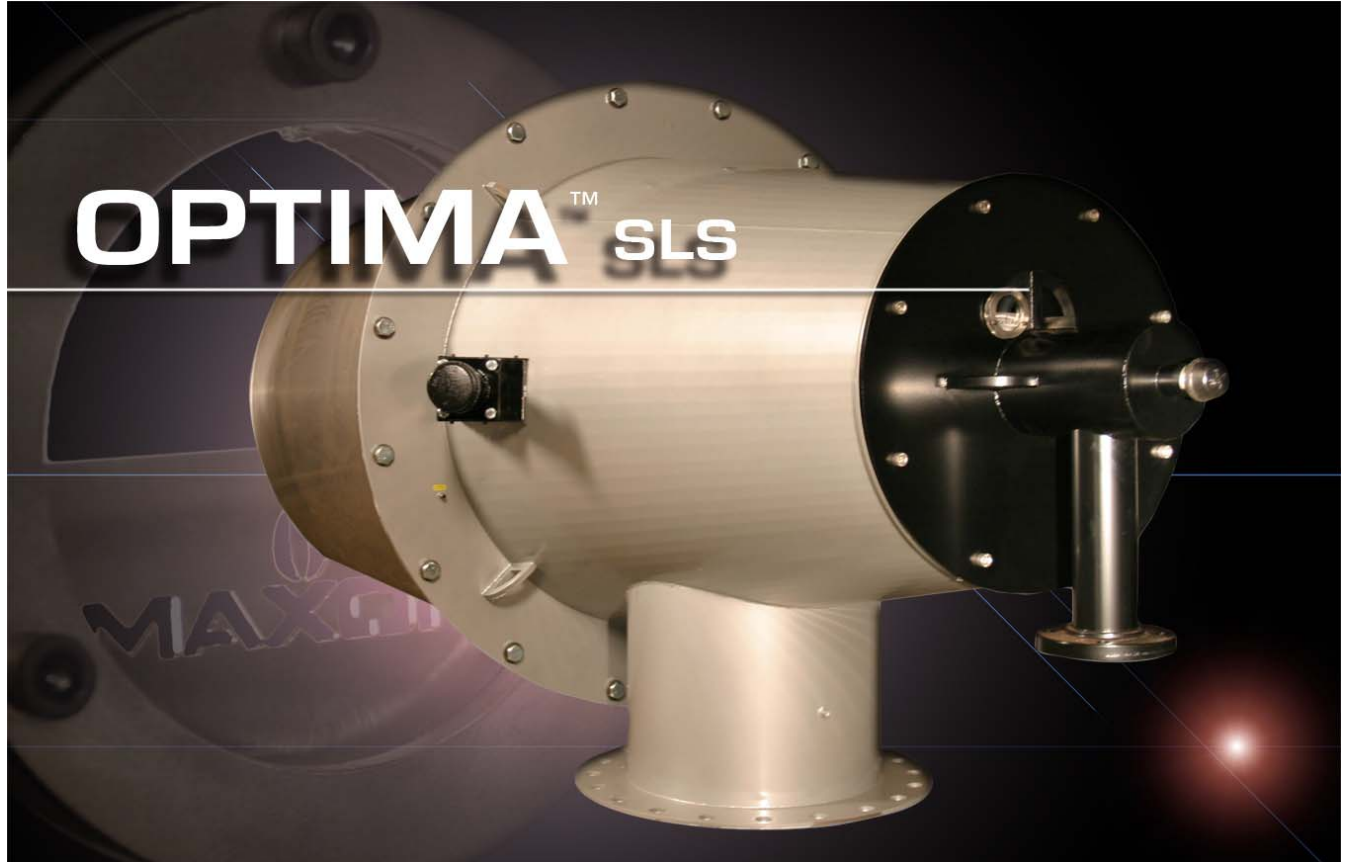

- Extremely clean, reliable heat with ultra low NO<sub>x</sub> and CO production for ease of air permitting and environmental compliance
- Large capacity heat releases with a compact, robust flame geometry
- Intelligent ratio control for reliable operation and optimal fuel efficiency
- Direct factory operational support with optional SMARTFIRE® control and communication gateway
- All steel and high temperature alloy construction for reduced weight and increased durability
- Fuel flexible with natural gas, propane, and butane capability. Contact MAXON for other fuels.
- Configurable for dryers, air heaters, ovens, kilns, process heaters, paper machines, and a variety of other industrial heating equipment

W W W . M A X O N C O R P . C O M

COMBUSTION SYSTEMS FOR INDUSTRY

Maxon reserves the right to alter specifications and data without prior notice.  
© 2016 Copyright Maxon Corporation. All rights reserved.

**Honeywell**

**MAXON**

## Product description

OPTIMA™ SLS is a nozzle-mixing, ultra low NO<sub>x</sub> and ultra low CO burner. The burner is suitable for installation in dryers (spray, flash, fluidized bed, print, paper and others), air heaters, kilns, process heaters, and ovens. The all-metal burner design provides very compact, repeatable heating with a flame fully contained in its discharge sleeve.

OPTIMA™ SLS provides optimal performance when coupled with MAXON's SMARTFIRE® Intelligent Ratio Control System. This advanced control package allows the burner to be fully factory preset for trouble-free installation and start-up. In addition, the intelligence of SMARTFIRE® keeps the burner fully optimized for fuel efficiency and emissions. With the optional communications gateway, your OPTIMA™ SLS Burner can be supported by MAXON over any common phone line.

## Available OPTIMA™ SLS sizes

Typical burner data										
Fuel: natural gas at 15°C with 10.9 kWh/Nm <sup>3</sup> HHV - sg = 0.6 [1]										
Combustion air: 15°C - 21% O <sub>2</sub> - 50% humidity - sg = 1.0 [1]										
Stated pressures are indicative. Actual pressures are a function of air humidity, altitude, type of fuel and gas quality										
Burner Size			8"	10"	12"	14"	16"	19"	22"	
Maximum Capacity	Heat Input	kW HHV	3800	6000	9700	12000	15109	20643	27400	
Fuel Pressure at burner inlet [2]	Differential Pressure	mbar	257	232	430	230	203	174	178	
Combustion Air Pressure [3]		mbar	80	80	80	80	80	80	80	
Turndown Ratio			8:1							

[1] sg (specific gravity) = relative density to air (density air = 1.293 kg/Nm<sup>3</sup>).

[2] Differential natural gas pressure required at burner gas inlet

[3] Differential combustion air pressure at full capacity measured at the air test port

## Applications

OPTIMA™ ultra low NO<sub>x</sub> burners have been especially designed for heating industrial processes requiring low output of NO<sub>x</sub> and CO. Its rugged steel and alloy design makes the burner suitable for industrial process stream applications, moist atmospheres, high process air temperatures and some indirect heating processes. The burner can operate very reliably in large heating applications to reduce environmental footprint and alleviate environmental permitting issues.

Typical applications:

- Paper, wood, gypsum and other dryers with air with high humidity content and high capacity needs.
- Indirect heating of product streams in coils where uniform heat transfer and reduced pollutants are required.
- Drying and curing of food products or paint products where reactions with combustion products must be minimized.

## Dimensions and weights

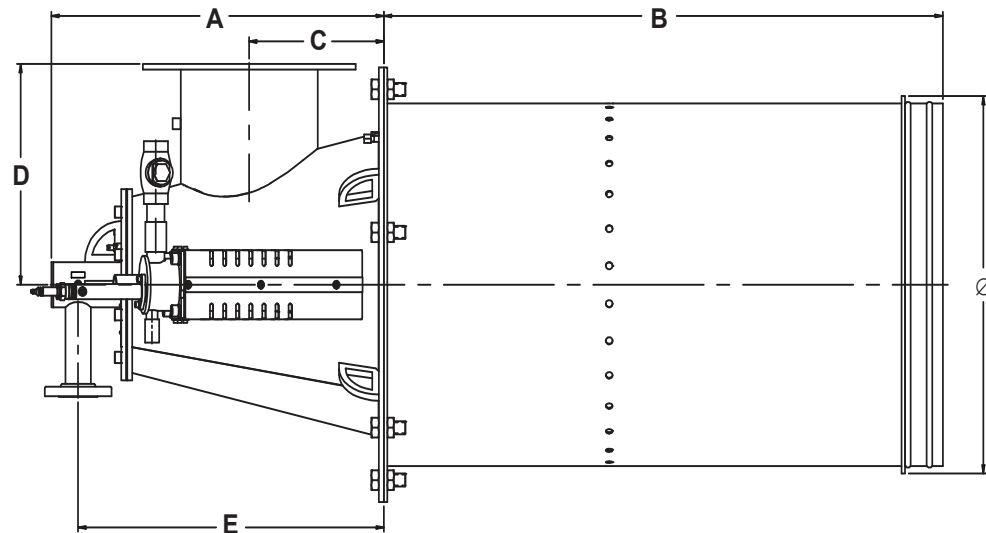

Dimensions inmm unless stated otherwise							
Burner Size	A	B	C	D Ø	E	Ø	Weight kg
8"	635	1066	258	375	584	640	160
10"	860	1066	326	465	732	793	235
12"	1168	1206	372	570	1020	945	340
14"	1236	1372	368	640	1148	1098	544
16"	1537	1524	390	765	1336	1250	590
19"	1606	1676	460	812	1460	1326	646
22"	1780	1803	476	850	1516	1396	794

## Typical emissions

OPTIMA™ SLS provides clean, reliable heat while producing extremely low levels of NO<sub>x</sub> and CO. The patented SLS technology (shear layer stabilization) contained in OPTIMA™ manages peak flame temperatures while the non-recirculating flame drives prompt NO<sub>x</sub> formation to near zero. CO production is eliminated through the advanced rapid mixing design and fully contained flame.

Exact emissions performance may vary in your application. Contact MAXON for information on installation-specific estimates and guaranteed values. No guarantee of emissions is intended or implied without specific, written guarantee from MAXON.

Read "Specifications of OPTIMA™ SLS burners" for correct and complete information on OPTIMA™ SLS burners.

## Specifications of OPTIMA™ SLS burners

Typical burner data								
Fuel: natural gas at 15°C with 10.9 kWh/Nm <sup>3</sup> HHV - sg = 0.6 [1]								
Combustion air: 15°C - 21% O <sub>2</sub> - 50% humidity - sg = 1.0 [1]								
Stated pressures are indicative. Actual pressures are a function of air humidity, altitude, type of fuel and gas quality.								
8" OPTIMA™ SLS								
Maximum capacity	Heat input	kW HHV	2300	2700	3000	3300	3600	3800
Combustion air	Differential pressure	mbar	30	40	50	60	70	80
	[4]		3231	3730	4171	4569	4935	5276
Minimum combustion air pressure	Vol. flow	m <sup>3</sup> /h						
	Differential pressure	mbar	1.2	1.2	1.2	1.2	1.2	1.2
Fuel - natural gas	Differential pressure[3]	mbar	97	128	161	193	225	257
Fuel - propane (2)	Differential pressure	mbar	39	52	64	77	90	103
Minimum capacity	Heat input	kW HHV	477	477	477	477	477	477
Turndown ratio			4.9	5.6	6.3	6.9	7.5	8.0
Approximate flame size	Length	m	1.2					
	Diameter	m	0.6					
Burner weight		kg	158					
Pilot capacity			kW HHV					
			36 - 73					
Pilot-natural gas	Differential pressure	mbar	4.0 - 15.9					

Typical burner data								
Fuel: natural gas at 15°C with 10.9 kWh/Nm <sup>3</sup> HHV - sg = 0.6 [1]								
Combustion air: 15°C - 21% O <sub>2</sub> - 50% humidity - sg = 1.0 [1]								
Stated pressures are indicative. Actual pressures are a function of air humidity, altitude, type of fuel and gas quality.								
10" OPTIMA™ SLS								
Maximum capacity	Heat input	kW HHV	3700	4200	4700	5200	5600	6000
Combustion air	Differential pressure	mbar	30	40	50	60	70	80
	[4]		5240	6080	6890	7450	7750	8293
Minimum combustion air pressure	Vol. flow	m <sup>3</sup> /h						
	Differential pressure	mbar	1.2	1.2	1.2	1.2	1.2	1.2
Fuel - natural gas	Differential pressure	mbar	87	116	145	174	203	232
Fuel - propane [2]	Differential pressure	mbar	34	46	58	70	81	92
Minimum capacity	Heat input	kW HHV	750	750	750	750	750	750
Turndown ratio			4.9	5.6	6.3	6.9	7.5	8.0
Approximate flame size	Length	m	1.3					
	Diameter	m	0.76					
Burner weight		kg	235					
Pilot capacity			kW HHV					
			36 - 73					
Pilot - natural gas	Differential pressure	mbar	4.0 - 15.9					

[1] sg (specific gravity) = relative density to air (density air = 1.293 kg/Nm<sup>3</sup>)

[2] Propane (25.90 kWh/Nm<sup>3</sup> HHV) sg = 1.52

[3] Differential natural gas pressure required at burner gas inlet

[4] Differential combustion air pressure at full capacity measured at the air test port

Typical burner data								
Fuel: natural gas at 15°C with 10.9 kWh/Nm <sup>3</sup> HHV - sg = 0.6 [1]								
Combustion air: 15°C - 21% O <sub>2</sub> - 50% humidity - sg = 1.0 [1]								
Stated pressures are indicative. Actual pressures are a function of air humidity, altitude, type of fuel and gas quality.								
12" OPTIMA™ SLS								
Maximum capacity	Heat input	kW HHV	5900	6900	7700	8400	9000	9700
Combustion air	Differential pressure [4]	mbar	30	40	50	60	70	80
	Vol. Flow	m <sup>3</sup> /h	8218	9489	10609	11622	12553	13420
Minimum combustion air pressure	Differential pressure	mbar	1.2	1.2	1.2	1.2	1.2	1.2
Fuel - natural gas	Differential pressure [3]	mbar	161	215	269	323	376	430
Fuel - propane [2]	Differential pressure	mbar	59	79	99	119	139	159
Minimum capacity	Heat input	kW HHV	1212	1212	1212	1212	1212	1212
Turndown ratio			4.9	5.6	6.3	6.9	7.5	8.0
Approximate flame size	Length	m	1.5					
	Diameter	m	0.91					
Burner weight		kg	340					
Pilot capacity		kW HHV	36 - 73					
Pilot - natural gas	Differential pressure	mbar	4.0 - 15.9					

Typical burner data								
Fuel: natural gas at 15°C with 10.9 kWh/Nm <sup>3</sup> HHV - sg = 0.6 [1]								
Combustion air: 15°C - 21% O <sub>2</sub> - 50% humidity - sg = 1.0 [1]								
Stated pressures are indicative. Actual pressures are a function of air humidity, altitude, type of fuel and gas quality.								
14" OPTIMA™ SLS								
Maximum capacity	Heat input	kW HHV	7350	8490	9487	10395	11244	12000
Combustion air	Differential pressure [4]	mbar	30	40	50	60	70	80
	Vol. Flow	m <sup>3</sup> /h	10164	11743	13120	14375	15550	16600
Minimum combustion air pressure	Differential pressure	mbar	1.2	1.2	1.2	1.2	1.2	1.2
Fuel - natural gas	Differential pressure [3]	mbar	86	115	144	172	202	230
Fuel - propane [2]	Differential pressure	mbar	32	43	53	63	74	85
Minimum capacity	Heat input	kW HHV	1500	1500	1500	1500	1500	1500
Turndown ratio			4.9	5.6	6.3	6.9	7.5	8.0
Approximate flame size	Length	m	1.7					
	Diameter	m	1.1					
Burner weight		kg	544					
Pilot capacity		kW HHV	36 - 73					
Pilot - natural gas	Differential pressure	mbar	4.0 - 15.9					

[1] sg (specific gravity) = relative density to air (density air = 1.293 kg/Nm<sup>3</sup>)

[2] Propane (25.90 kWh/Nm<sup>3</sup> HHV) sg = 1.52

[3] Differential natural gas pressure required at burner gas inlet

[4] Differential combustion air pressure at full capacity measured at the air test port

Typical burner data								
Fuel: natural gas at 15°C with 10.9 kWh/Nm <sup>3</sup> HHV - sg = 0.6 [1]								
Combustion air: 15°C - 21% O <sub>2</sub> - 50% humidity - sg = 1.0 [1]								
Stated pressures are indicative. Actual pressures are a function of air humidity, altitude, type of fuel and gas quality.								
16" OPTIMA™ SLS								
Maximum capacity	Heat input	kW HHV	9253	10687	11947	13089	14143	15109
Combustion air	Differential pressure [4]	mbar	30	40	50	60	70	80
	Vol. flow	m <sup>3</sup> /h	12797	14777	16521	18098	19548	20898
Minimum combustion air pressure	Differential pressure	mbar	1.2	1.2	1.2	1.2	1.2	1.2
Fuel - natural gas	Differential pressure [3]	mbar	76	101	127	152	178	203
Fuel - propane [2]	Differential pressure	mbar	30	41	51	61	71	81
Minimum capacity	Heat input	kW HHV	1889	1889	1889	1889	1889	1889
Turndown ratio			4.9	5.7	6.3	6.9	7.5	8.0
Approximate flame size	Length	m	1.8					
	Diameter	m	1.2					
Burner weight			kg 589					
Pilot capacity			kW HHV 36 - 73					
Pilot - natural gas	Differential pressure	mbar	4.0 - 15.9					

Typical burner data								
Fuel: natural gas at 15°C with 10.9 kWh/Nm <sup>3</sup> HHV - sg = 0.6 [1]								
Combustion air: 15°C - 21% O <sub>2</sub> - 50% humidity - sg = 1.0 [1]								
Stated pressures are indicative. Actual pressures are a function of air humidity, altitude, type of fuel and gas quality								
19" OPTIMA™ SLS								
Maximum capacity	Heat input	kW HHV	12649	14611	16310	17890	19296	20643
Combustion air	Differential pressure [4]	mbar	30	40	50	60	70	80
	Vol. flow	m <sup>3</sup> /h	17482	20186	22569	24723	26704	28548
Minimum combustion air pressure	Differential pressure	mbar	1.2	1.2	1.2	1.2	1.2	1.2
Fuel - natural gas	Differential pressure [3]	mbar	65	87	109	131	152	174
Fuel - propane [2]	Differential pressure	mbar	24	32	40	48	54	64
Minimum capacity	Heat input	kW HHV	2577	2577	2577	2577	2577	2577
Turndown ratio			4.9	5.6	6.3	6.9	7.5	8.0
Approximate flame size	Length	m	2.1					
	Diameter	m	1.4					
Burner weight			kg 646					
Pilot capacity			kW HHV 36 - 73					
Pilot - natural gas	Differential pressure	mbar	4 - 15.9					

[1] sg (specific gravity) = relative density to air (density air = 1.293 kg/Nm<sup>3</sup>)

[2] Propane (25.90 kWh/Nm<sup>3</sup> HHV) sg = 1.52

[3] Differential natural gas pressure required at burner gas inlet

[4] Differential combustion air pressure at full capacity measured at the air test port

Typical burner data								
Fuel: natural gas at 15°C with 10.9 kWh/Nm <sup>3</sup> HHV - sg = 0.6 [1]								
Combustion air: 15°C - 21% O <sub>2</sub> - 50% humidity - sg = 1.0 [1]								
Stated pressures are indicative. Actual pressures are a function of air humidity, altitude, type of fuel and gas quality								
22" OPTIMA™ SLS								
Maximum capacity	Heat input	kW HHV	16700	19500	21600	23700	25600	27400
Combustion air	Differential pressure [4]	mbar	30	40	50	60	70	80
	Vol. flow	m <sup>3</sup> /h	23179	26765	29924	32781	35407	37852
Minimum combustion air pressure	Differential pressure	mbar	1.2	1.2	1.2	1.2	1.2	1.2
Fuel - natural gas	Differential pressure [3]	mbar	67	89	111	133	155	178
Fuel - propane [2]	Differential pressure	mbar	27	36	44	53	62	71
Minimum capacity	Heat input	kW HHV	3423	3423	3423	3423	3423	3423
Turndown ratio			4.9	5.6	6.3	6.9	7.5	8.0
Approximate flame size	Length	m	2.4					
	Diameter	m	1.5					
Burner weight		kg	794					
Pilot capacity		kW HHV	36 - 73					
Pilot - natural gas	Differential pressure	mbar	4.0 - 15.9					

[1] sg (specific gravity) = relative density to air (density air = 1.293 kg/Nm<sup>3</sup>)

[2] Propane (25.90 kWh/Nm<sup>3</sup> HHV) sg = 1.52

[3] Differential natural gas pressure required at burner gas inlet

[4] Differential combustion air pressure at full capacity measured at the air test port

## Materials of construction

Burner Housing	Carbon Steel, powder coated (TGIC) AISI 1008 / 1010 (1.1121)
Burner Sleeve	AISI 330 Stainless Steel (1.4333)
Burner Cone	AISI 330 Stainless Steel (1.4333)
Fuel Injector Nozzle	AISI 304 Stainless Steel (1.4301)

## Selection criteria

### Application details

---

OPTIMA™ SLS burners provide reliable, clean heat in applications with a moving stream or process flow. Indirect fired applications are also permissible with proper configuration of the burner (contact MAXON). The burner may be installed on processes with suction or back pressures up to 103 mbar. Contact MAXON if higher application pressures are required for special gasketing options.

### Burner protection

---

The flame scanner must have a cooling air flow of 1.7 m<sup>3</sup>/h. This can be supplied by the combustion air blower. It should be connected to the tee on the flame scanner pipe nipple. An adjustable orifice can be used for fine control.

### Pilot

---

The pilot gas valve should be located close to the burner for quick ignition.

An interrupted pilot is required for safe operation and ignition.

Pilot flow and pressure requirements for each burner are shown in the OPTIMA™ Capacities and Specifications chart.

Pilot air may be required in applications with high moisture or low oxygen content. In basic air heating applications, a raw gas pilot and/or direct spark ignition is permissible as long as oxygen levels remain over 18% and the air stream is not heavily saturated where condensation could occur within the pilot assembly.

### Multiple burners manifolded to a single blower

---

For good air distribution, the air manifold should extend one diameter past the burner inlet with the burner feeding from a tee rather than an elbow.

For maximum flexibility, each burner should have its own pilot and main gas regulators.

Proper air manifold sizing using the equal area method should be utilized. Conscientious manifold design will allow maximum turndown and best performance.

### Process temperature

---

Application temperatures are limited to 540°C with moving process flows. The OPTIMA™ SLS should be installed so that radiant energy is released to the process and not trapped around the burner sleeve. Avoid packing insulation directly against the discharge sleeve beyond the first 150 mm. Process flows should flow over the discharge sleeve to provide the longest practical service life.

### Piloting & ignition

---

Interrupted pilots are required for optimal ignition and emissions performance.

MAXON does not recommend the use of standing pilots as the burner is not intended to confirm main flame/pilot flame scanner discrimination.

OPTIMA™ pilots may operate with raw gas in some applications. Where high moisture or oxygen < 18% by volume is present, combustion air must be piped to the pilot for reliable operation.

### Ratio control

---

OPTIMA™ SLS Burners produce ideal emissions with constant 43% excess air. Operation at other ratios is permissible depending upon application and emissions requirements. Contact MAXON for details.

OPTIMA™ SLS burners perform best when equipped with the SMARTFIRE® self compensating, intelligent ratio control system. This system provides optimal operation of the burner for efficiency, reliability, and emissions control. Variations in combustion air temperature, barometric pressure and process application pressures will be corrected by the SMARTFIRE® system. In stable pressure applications, SMARTFIRE® may be substituted for SMARTLINK® digital ratio control. Contact MAXON for details.

### Flame supervision

---

The OPTIMA™ SLS burner is arranged for use with UV or IR scanners as flame detectors. The standard flame supervision location will detect both main flame and pilot flame. Do not use standing pilots in this arrangement.



## Piping

---

Follow all applicable codes including regional codes, local directives, standards and recommendations of your insurance carrier when designing and installing OPTIMA™ SLS burners. Installation should only be undertaken by qualified gas contractors licensed for any regional or local requirements.

Piping weight should be independently supported. Do not use the burner as a piping support or hang weight from the burner's flange connections.

Do not utilize hydraulic leak tests on piping feeding burner systems. Avoid the use of teflon tape or other pipe tape for sealing pipe threads.

## Fuels

---

The OPTIMA™ SLS is designed to burn a variety of fuels and fuel blends. Optimal emissions performance will occur with clean, dry fuel gases such as natural gas, propane, and butane. Contact MAXON for information on combusting special fuels, fuels with low heating value, and fuels with corrosive constituents.

## Expected emissions

---

Typical emissions for the OPTIMA™ SLS with 43% excess air:

NO<sub>x</sub> < 9 - 15 ppm corrected to 3% Oxygen

Production of various pollutants can be highly dependent upon burner application and installation. Differing temperatures, process velocities, oxygen levels, and fuels can all impact the actual level of emissions produced. No guarantee of emissions is intended or implied without specific evaluation and written guarantee by MAXON.

## Dimensions

### 8" OPTIMA™ SLS

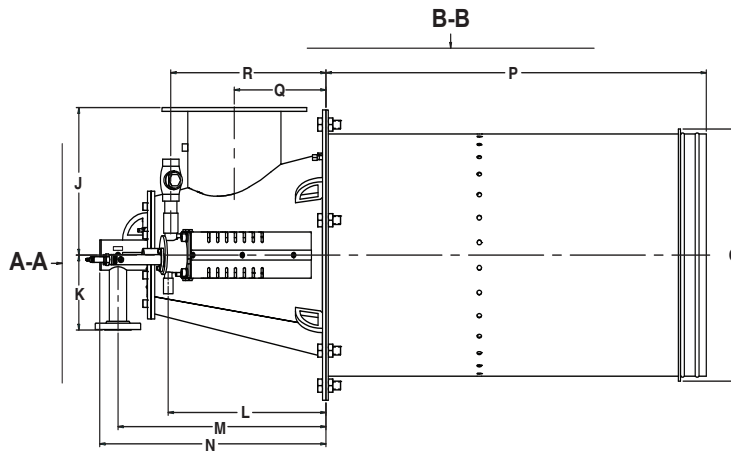

View A-A

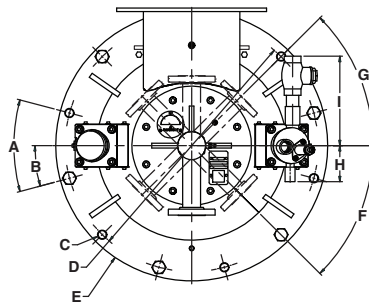

View B-B

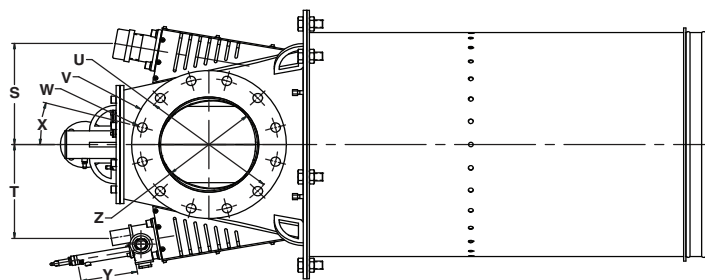

750 mm clearance required to remove burner nozzle

Dimensions in mm unless stated otherwise

A	B	C Ø	D Ø	E Ø	F	G	H	I	J	K	L	M
30°	15°	22	686	736	45°	45°	98	244	375	190	442	584

N	O Ø	P	Q	R	S	T	U Ø	V Ø	W Ø	X	Y	Z Ø
635	641	1066	258	436	278	258	362	406	25	15°	150	254

10" OPTIMA™ SLS

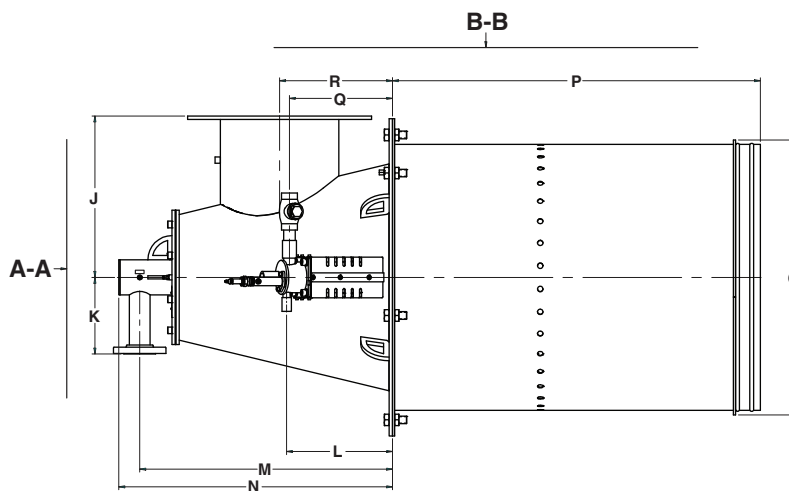

View A-A

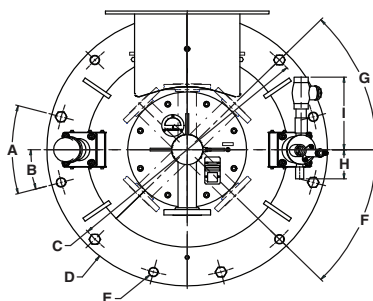

View B-B

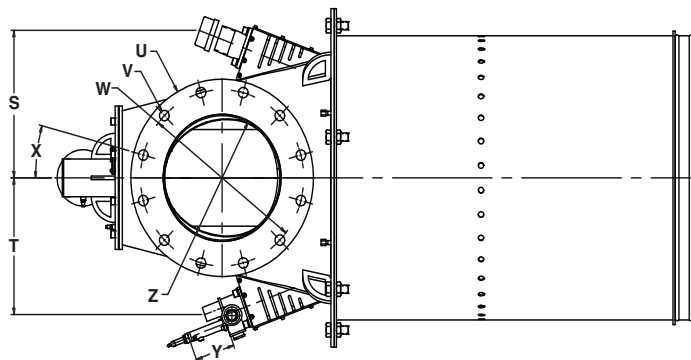

902 mm clearance required to remove burner nozzle

Dimensions in mm unless stated otherwise												
A	B	C Ø	D Ø	E Ø	F	G	H	I	J	K	L	M
30°	15°	850	915	28	45°	45°	98	244	465	220	306	732

N	O Ø	P	Q	R	S	T	U Ø	V Ø	W Ø	X	Y	Z Ø
793	793	1066	298	326	388	370	534	28	476	15°	115	336

WWW.MAXONCORP.COM

COMBUSTION SYSTEMS FOR INDUSTRY

Maxon reserves the right to alter specifications and data without prior notice.  
© 2016 Copyright Maxon Corporation. All rights reserved.

**Honeywell**

**MAXON**

12" OPTIMA™ SLS

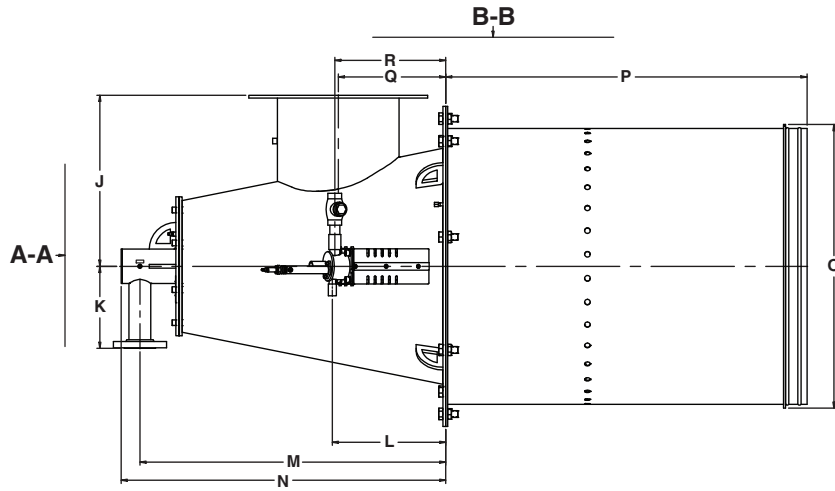

View A-A

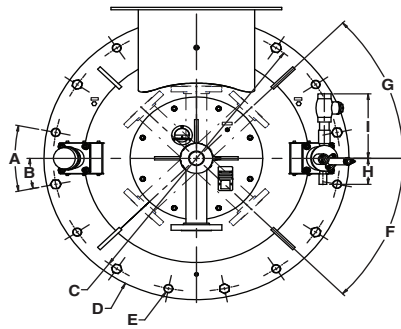

View B-B

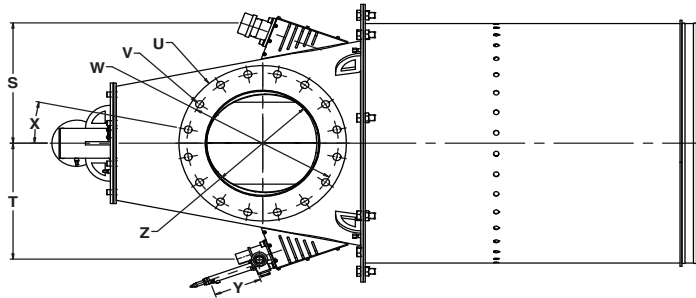

1156 mm clearance required to remove burner nozzle

Dimensions in mm unless stated otherwise

A	B	C Ø	D Ø	E Ø	F	G	H	I	J	K	L	M
22.5°	11.25°	285	1066	28	45°	45°	98	244	570	274	378	1020

N	O Ø	P	Q	R	S	T	U Ø	V Ø	W Ø	X	Y	Z Ø
1084	945	1206	358	370	464	446	596	28	540	11.25°	171	400



WWW.MAXONCORP.COM

COMBUSTION SYSTEMS FOR INDUSTRY

Maxon reserves the right to alter specifications and data without prior notice.

© 2016 Copyright Maxon Corporation. All rights reserved.

14" OPTIMA™ SLS

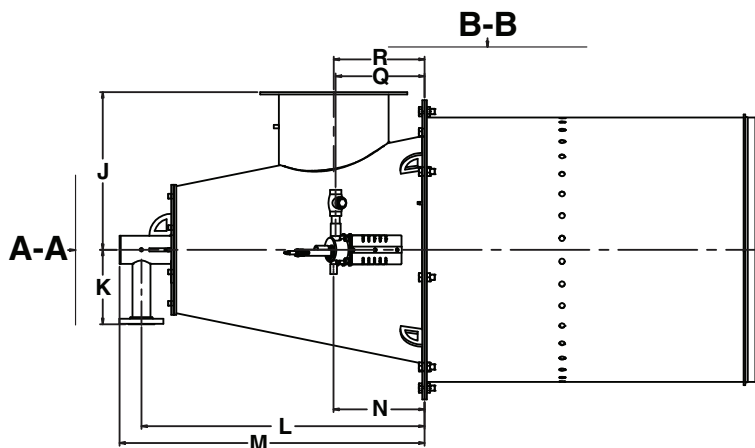

View A-A

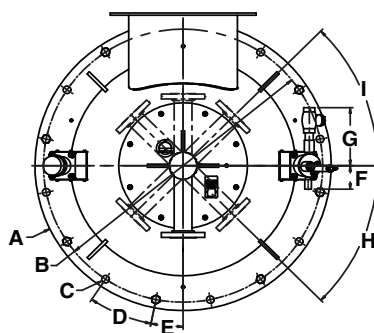

View B-B

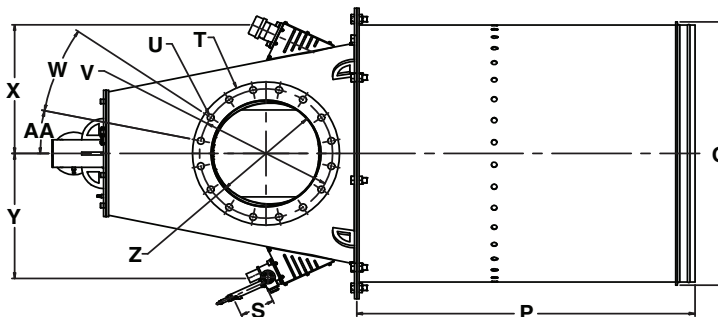

1220 mm clearance required to remove burner nozzle

Dimensions in mm unless stated otherwise													
A Ø	B Ø	C Ø	D	E	F	G	H	I	J	K	L	M	N
1212	1143	28	22.5°	11.25°	98	244	45°	45°	640	302	1148	1236	370

O Ø	P	Q	R	S	T Ø	U Ø	V Ø	W	X	Y	Z Ø	AA
1098	1372	360	368	142	596	28	540	22.5°	538	520	438	11.25°

16" OPTIMA™ SLS

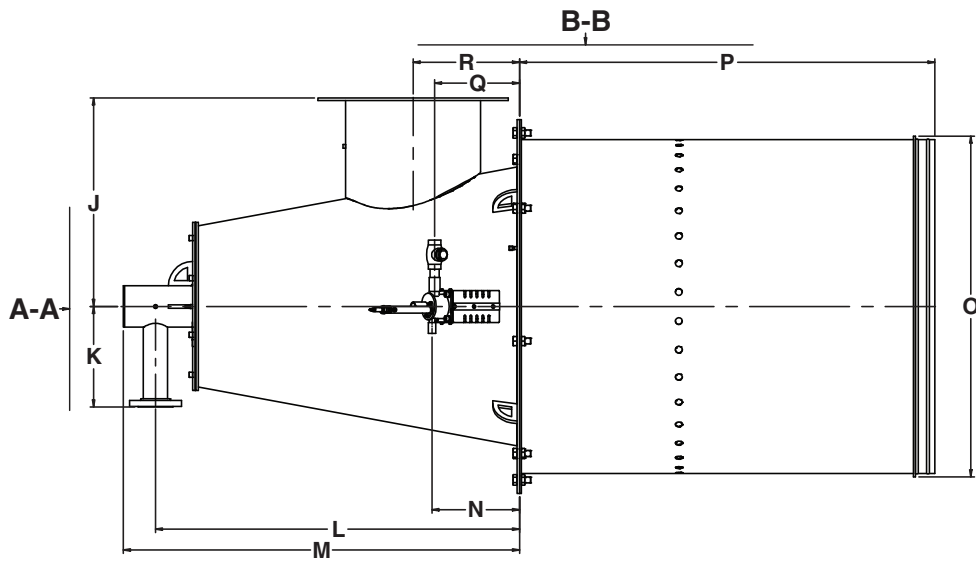

View A-A

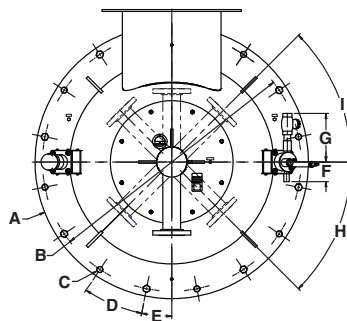

View B-B

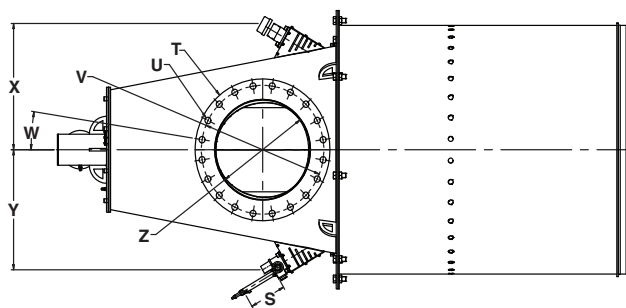

1460 mm clearance required to remove burner nozzle

Dimensions in mm unless stated otherwise

A Ø	B Ø	C Ø	D	E	F	G	H	I	J	K	L	M
1372	1298	28	22.5°	11.25°	98	244	45°	45°	765	368	1336	1453

N	O Ø	P	Q	R	S	T Ø	U Ø	V Ø	W	X	Y	Z Ø
320	1250	1524	312	390	189	698	32	635	9°	606	592	488



WWW.MAXONCORP.COM

COMBUSTION SYSTEMS FOR INDUSTRY

Maxon reserves the right to alter specifications and data without prior notice.

© 2016 Copyright Maxon Corporation. All rights reserved.

19" OPTIMA™ SLS

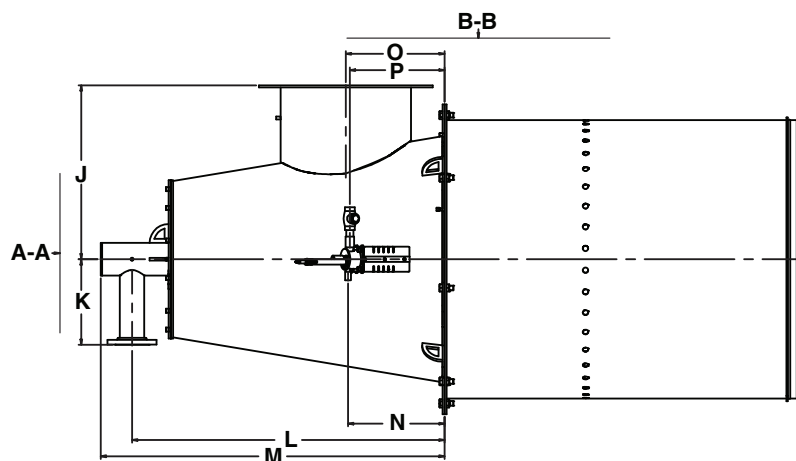

View A-A

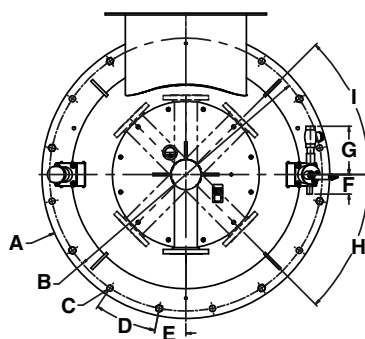

View B-B

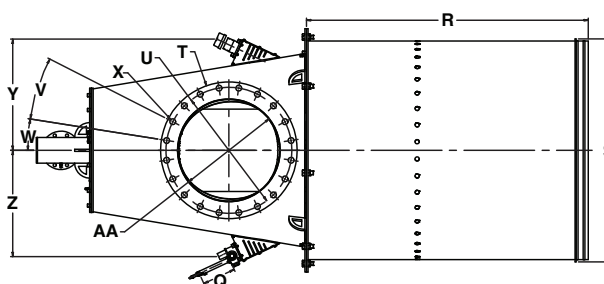

1498 mm clearance required to remove burner nozzle

Dimensions in mm unless stated otherwise													
A Ø	B Ø	C Ø	D	E	F	G	H	I	J	K	L	M	N
1448	1374	28	22.5°	11.25°	98	243	45°	45°	812	400	1460	1606	452

O	P	Q	R	S Ø	T Ø	U Ø	V	W	X Ø	Y	Z	AA Ø
462	442	199	1676	1326	812	35	18°	9°	750	648	632	610

22" OPTIMA™ SLS

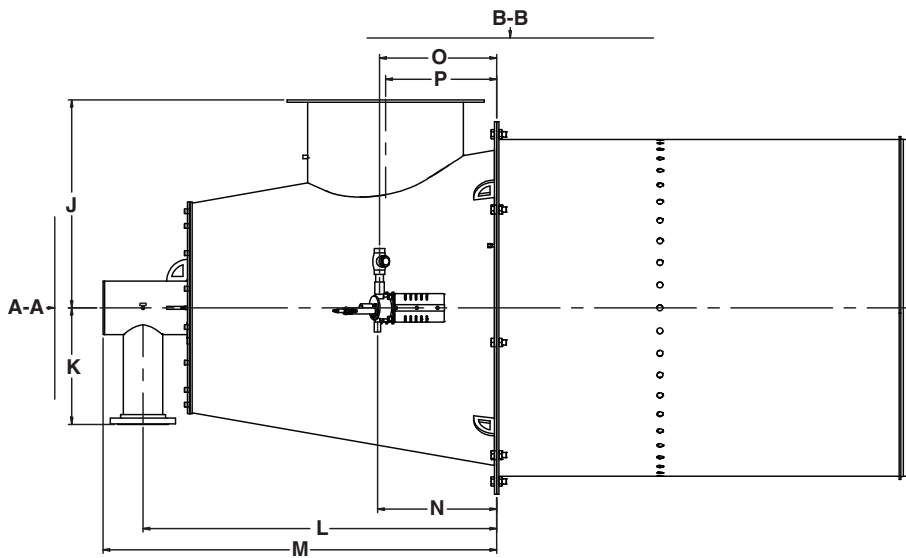

View A-A

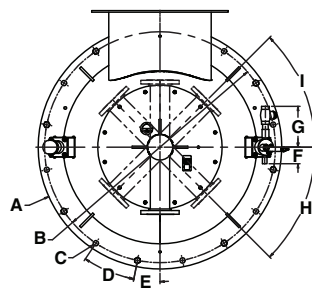

View B-B

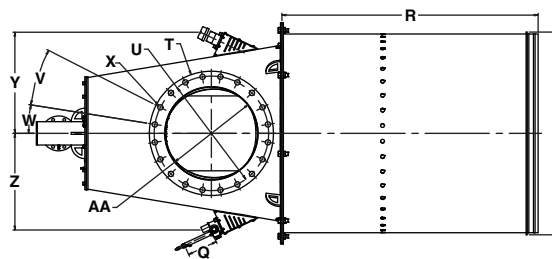

1940 mm clearance required to remove burner nozzle

Dimensions in mm unless stated otherwise

A Ø	B Ø	C Ø	D	E	F	G	H	I	J	K	L	M
1448	1524	28	22.5°	11.25°	98	244	45°	45°	850	476	1516	1688

N	O	P	Q	R	S Ø	T Ø	U Ø	V	W	X Ø	Y	Z	AA Ø
512	502	476	130	1804	1396	845	32	20°	10°	762	706	690	660



W W W . M A X O N C O R P . C O M

COMBUSTION SYSTEMS FOR INDUSTRY

Maxon reserves the right to alter specifications and data without prior notice.

© 2016 Copyright Maxon Corporation. All rights reserved.



### Component identification and fuel inlet positions

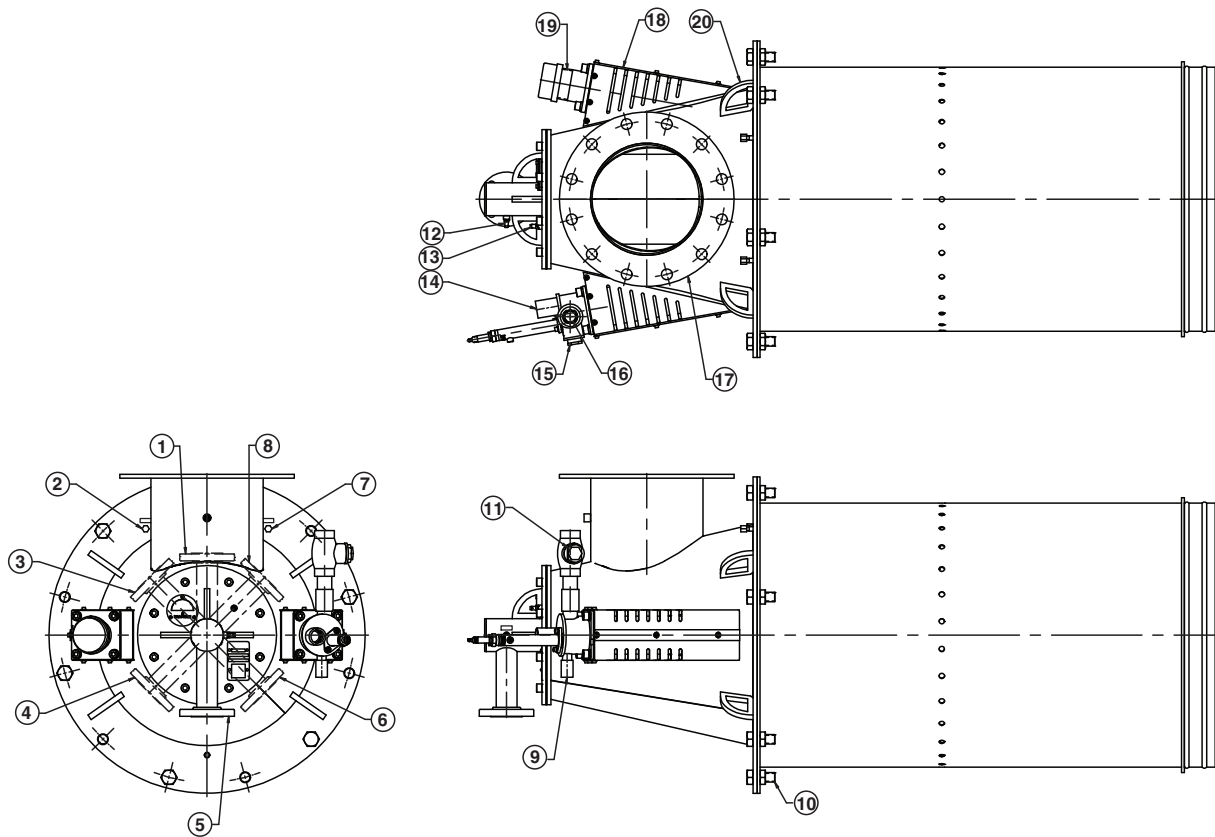

Number	Description	Number	Description
1	Fuel inlet position #4	11	Pilot air adjustable orifice
2	1/8" NPT chamber pressure tap	12	1/8" NPT fuel pressure tap
3	Fuel inlet position #3	13	1/8" NPT combustion air pressure tap
4	Fuel inlet position #2	14	1" NPT coupling for UV scanning
5	Fuel inlet, Class 150 RF steel pipe flange, position #1 (see note below)	15	Pilot and spark ignitor assembly; position "right" shown
6	Fuel inlet position #6	16	1" NPT pilot air inlet connection
7	1/8" NPT chamber pressure tap	17	Flange diameter and bolt pattern matches standard ANSI flange (see note below)
8	Fuel inlet position #5	18	Pilot position "left"
9	1/2" NPT pilot fuel inlet	19	2-1/2" NPT alternate scanning port
10	7/8-9 hex head bolts and nuts, if required, are to be used for shipping purposes only	20	Lifting lugs

**NOTES:**

**Number 5:** 8" burner = 1-1/2" flange; 10" burner = 2" flange; 12" burner = 2-1/2" flange; 14" burner = 2-1/2" flange; 16" burner = 3" flange; 19" burner = 4" flange; 22" burner = 6" flange

**Number 17:** 8" burner = 10" flange; 10" burner = 14" flange; 12" burner = 16" flange; 14" burner = 20" flange; 16" burner = 20" flange; 19" burner = 24" flange; 22" burner = 26" flange

## Intelligent Model Numbers

A coded model number is provided on the nameplate of all OPTIMA™ burners to provide a simple method to identify the configuration of the product. This model number ensures accuracy in identifying your product, ordering replacement parts or communicating capabilities.

Burner series	Size	Fuel	Fuel inlet orientation	Pilot location	Sleeve/cone material	Companion flange	Scanner focusing lens
OPT	08	N	1	R	HT	N	1

### Burner series

OPT = OPTIMA

### Size

08 - 8"  
10 - 10"  
12 - 12"  
14 - 14"  
16 - 16"  
19 - 19"  
22 - 22"

### Fuel

C - Combination  
N - Natural gas  
P - Propane

### Fuel inlet orientation

1 - Position 1  
2 - Position 2  
3 - Position 3  
4 - Position 4  
5 - Position 5  
6 - Position 6

### Pilot location

L - Left  
R - Right

### Sleeve/cone material

HT - High temp 330SS

### Companion flange

N - None  
S - Standard companion flange

### Focusing lens for scanner

1 - Honeywell 1104238  
2 - Fireye 1104237  
3 - PCI/other It wt 1040893  
4 - None

## Installation and operating instructions for OPTIMA™ SLS burner

### Application requirements

#### View port

A view port to observe burner flame is essential to inspect flame aspect. Locate the view port downstream of the flame, looking back in to the burner sleeve. Make sure the complete flame can be evaluated.

#### Support burner air and gas piping

The OPTIMA™ SLS burner shall not be used as support for the piping to the burner. Gas and air piping shall be supported in such a way that no additional loads will be created on the burner.

#### Burner protection

Most UV/IR scanners generally have recommended maximum exposure temperatures. Consult the operating instructions for your selected flame detector. Cooling air may be required. In cases of high chamber temperatures (above 430°C) and/or back pressures, it may be required to purge the burner with a small amount of cooling air. This can be achieved with keeping the combustion air blower on, and the air control valve in minimum position.

#### SMARTFIRE® and SMARTLINK® Control System

Consult the SMARTFIRE® or SMARTLINK® installation and operation instructions. Only adequate regulator adjustment will be required as SMARTFIRE® is a compensating closed loop air/fuel ratio control system. For burners equipped with SMARTLINK®, consult the appropriate operating and instruction manual.

## Installation instructions

### Storage of OPTIMA™ SLS burners

---

OPTIMA™ SLS burners shall be stored dry (inside).

### Handling of OPTIMA™ SLS burners

---

OPTIMA™ SLS burners are shipped as complete units. Handle burners with care during unpacking, transport, lifting and installation. Use proper equipment. Any impact on the burner could result in damage.

### Test connections

---

Install test fittings, tubes, and manometers or gauges at the air, gas and chamber pressure test connections on the burner. Air and gas pressures must be read differentially against the system chamber pressure.

### Mounting

---

Burner may be mounted at any orientation.

An upward-facing flame scanner can lose signal over time as water and debris fall on the lens.

Ensure burner weight is adequately supported. Thin skin walls may require stiffening plates or additional structural support.

### Combustion air supply

---

No air filtration is necessary for the OPTIMA™ burner because of its open internal structure for most applications. In especially dirty or dusty environments like gypsum plants, textile mills or foundries, air filtration is recommended.

SMARTFIRE® control system will compensate for fluctuations in combustion air temperature, barometric pressure and chamber pressure.

Combustion air control valve and combustion air blower may be close coupled to burner air inlet. Consider rotation of air control butterfly when piping.

(Allow 5 Ø minimum straight pipe length between air control valve and burner. An elbow is permissible at the burner inlet with 1 Ø of straight connecting pipe.)

## Burner mounting

Consult burner weights when designing mounting penetrations. Do not hang OPTIMA™ SLS burners on thin walled vessel skins without added support. Size burner penetrations 50 mm to 76 mm larger than discharge sleeve diameter. Insulation may be packed onto discharge sleeve for the first 152 mm of length.

Do not fully insulate sleeves. Do not trap sleeves in highly radiant environments or refractory structures.

Optimal sleeve life will occur where discharge sleeves are kept in moving process flows. For optimal emissions performance, protect discharge sleeve exit from perpendicular process velocities >914 m/m. Do not orient burners where process flows will travel into discharge sleeve.

- 1) Cut opening 13 mm larger than sleeve diameter with stiffening ring
- 2) Additional stiffener plate may be required. Check burner weights
- 3) Heater shell
- 4) Insulated wall
- 5) This area may be packed with insulation up to 152 mm on sleeve
- 6) Ensure heater shell can support burner weight. If not, add a stiffening plate or support burner weight by other means.
- 7) Mounting studs (by others)
- 8) Rope gasket included with burner

Sketch 1

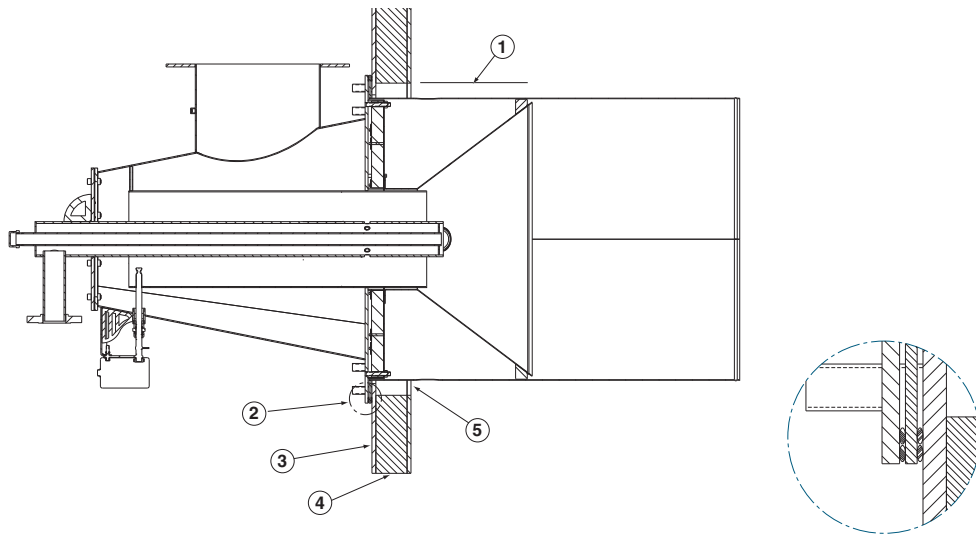

Sketch 2

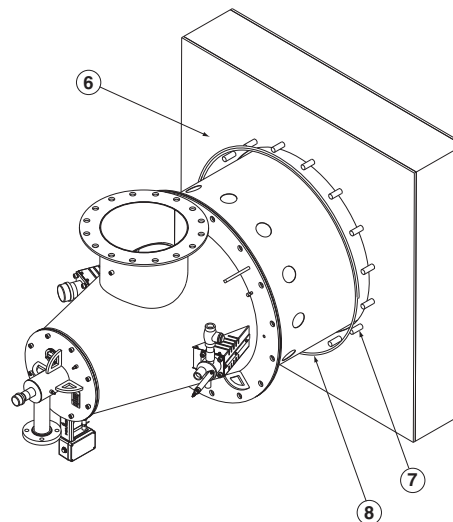

## Start-up instructions

Instructions provided by the company or individual responsible for the manufacture and/or overall installation of a complete system incorporating MAXON burners take precedence over the installation and operating instructions provided by MAXON. If any of the instructions provided by MAXON are in conflict with local codes or regulations, please contact MAXON before initial start-up of equipment.



Read the combustion system manual carefully before initiating the start-up and adjustment procedure. Verify that all of the equipment associated with and necessary to the safe operation of the burner system has been installed correctly, that all pre-commissioning checks have been carried out successfully and that all safety related aspects of the installation are properly addressed.

Initial adjustment and light-off should be undertaken only by a trained commissioning engineer.

### SMARTFIRE® Control System

---

Refer to the SMARTFIRE® instruction section for complete start-up instructions.

### Typical ignition sequence

---

- Pre-purge of burner and installation, according to the applicable codes and the installation's requirements.
- Combustion air control valve shall be in the minimum position to allow minimum combustion air flow to the burner.
- Pre-ignition (typically 2 seconds sparking in air)
- Open pilot gas and continue to spark the ignitor (typically 5 to 10 seconds depending on local code requirement).
- Stop sparking, continue to power the pilot gas valves and start flame check. Trip burner if no flame from here on.
- Check pilot flame stability (typical 5 to 10 seconds to prove stable pilot).
- Open main gas valves and allow enough time to have main gas in the burner (typical 5 seconds + time required to have main gas in the burner).
- Close the pilot gas valves.
- Release to modulation (allow modulation of the burner).
- Above sequence shall be completed to include all required safety checks during the start-up of the burner (process and burner safeties).
- Position 1 (one) pilot gas valve as close as possible to the pilot burner gas inlet for fast ignition of the pilot burner.

## Maintenance and inspection instructions

Regular inspection, testing and recalibration of combustion equipment according to the installation manual is an integral part of its safety. Inspection activities and frequencies shall be carried out as specified in the installation manual.

- Perform the following activities at least annually as part of a recommended preventative maintenance routine.
- Inspect burner internal parts for wear or oxidation.
- Inspect associated control instruments and devices for function with particular attention to all safety permissive switches.
- Perform leak tests on fuel shut-off valves according to any schedule established by the authority having jurisdiction.
- Clean or replace combustion air filters if present.
- Clean gas filters and drain drip legs in fuel train.
- Assess combustion spare parts and restock. For the OPTIMA™ SLS burner, MAXON recommends keeping spare spark ignitors, a SMARTFIRE® actuator, and spare flow probes.



W W W . M A X O N C O R P . C O M

COMBUSTION SYSTEMS FOR INDUSTRY

Maxon reserves the right to alter specifications and data without prior notice.  
© 2016 Copyright Maxon Corporation. All rights reserved.