

Eclipse Furnnox Burners

Model FN0200

Data sheet Edition 04.18

Version 1

Parameter		Specification			
		Natural Gas	Propane	Butane	
Maximum Input, Btu/h (kW) <i>Input limited during cold start. See page 2.</i>		2,000,000 (527)	2,000,000 (527)	2,000,000 (527)	
Minimum Input, Btu/h (kW) <i>For lower inputs, contact Eclipse, Inc.</i>		200,000 (52.7)	200,000 (52.7)	200,000 (52.7)	
Main Gas Inlet Pressure, "w.c. (mbar) <i>Fuel pressure at gas inlet (Tap B)</i>	Combustion Air Temp	Ambient Air	3.8 (9.4)	6.4 (15.9)	5.9 (14.6)
		300°F (150°C)	5.8 (14.4)	6.6 (16.4)	6.2 (15.4)
Air Inlet Pressure, "w.c. (mbar) <i>15% excess air at maximum input Tap A (see page 3)</i>	Combustion Air Temp	Ambient Air	13.7 (34.1)	13.7 (34.1)	13.7 (34.1)
		300°F (150°C)	19.6 (48.8)	19.6 (48.8)	19.6 (48.8)
High Fire Visible Flame Length, inches (mm) <i>Measured from the outlet end of the combustor</i>		<36.0 (914)	<32.0 (813)	<32.0 (813)	
Maximum Combustion Air Temperature, °F (°C) <i>For higher combustion air temperatures, contact Eclipse, Inc.</i>		300 (150)			
Minimum Operating Furnace Temperature, °F (°C) <i>For operation with low NO_x and lowest CO emissions</i>		1400 (760)			
Maximum Chamber Temperature, °F (°C)		2400 (1315)			
Flame Detection		UV Scanner			
Fuels¹ <i>For any other mixed gas, contact Eclipse, Inc.</i>		Natural Gas, Propane, Butane			
Approvals					

1) See Installation Guide 210 for more information about typical fuel composition and properties.

- All information based on laboratory testing in neutral (0.0" w.c.) pressure chamber. Different chamber sizes and conditions may affect the data.
- All imperial inputs based upon gross calorific values (HHV). All metric inputs based upon net calorific values (LHV).
- Eclipse reserves the right to change the construction and/or configuration of our products at any time without being obliged to adjust earlier supplies accordingly.
- Plumbing of air and gas will affect accuracy of orifice readings. All information is based on general acceptable air and gas piping practices.

Performance Graphs

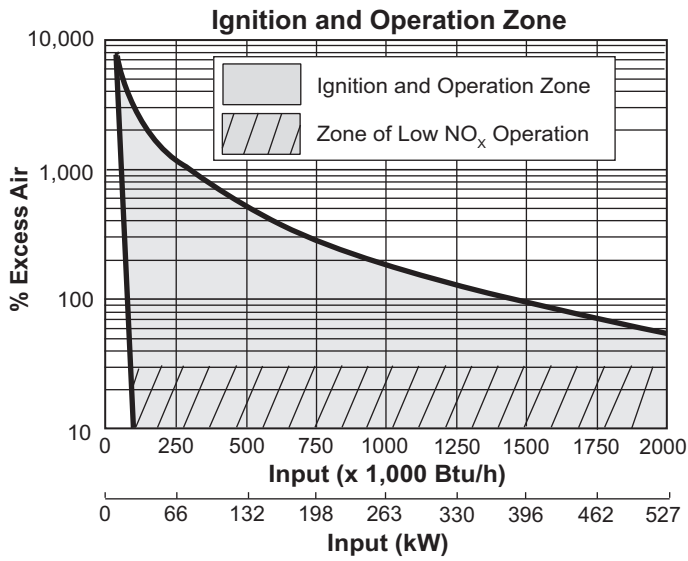

Input to be limited to 1.5 MM Btu/h (396 kW) with Minimum of 30% EXA, while the chamber is below 1400°F (760°C).

Emissions from the burner are influenced by:

- Fuel type
- Combustion air temperature
- Firing rate
- Chamber conditions
- Percent of excess air

High fire NO_x emissions with natural gas are typically below 30 ppm at 3% O₂ in furnace applications below 2000°F. Contact Eclipse for an estimate of emissions for specific conditions.

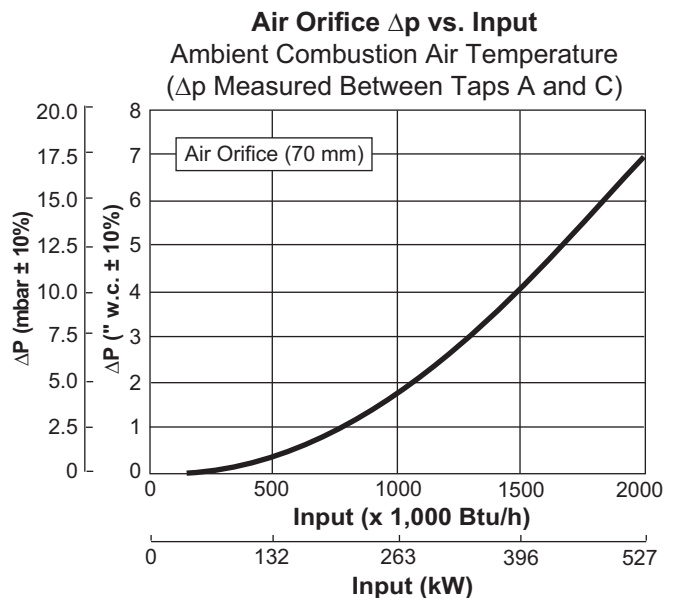
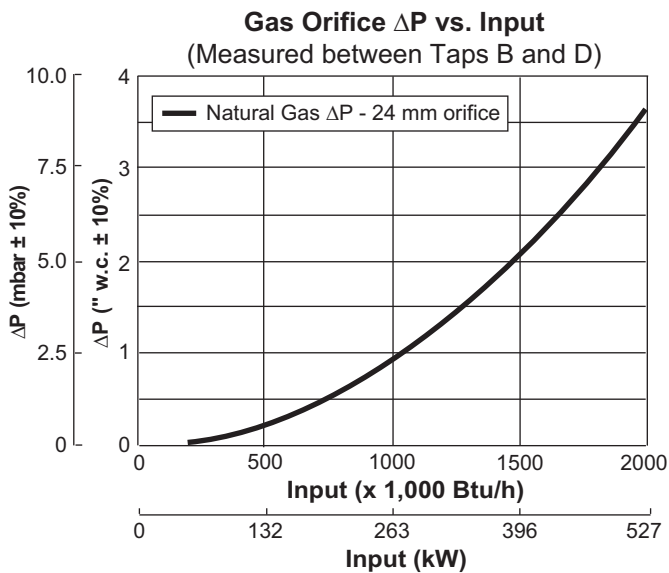

Dimensions and Specifications

Dimensions in mm (inches)

Burner Body

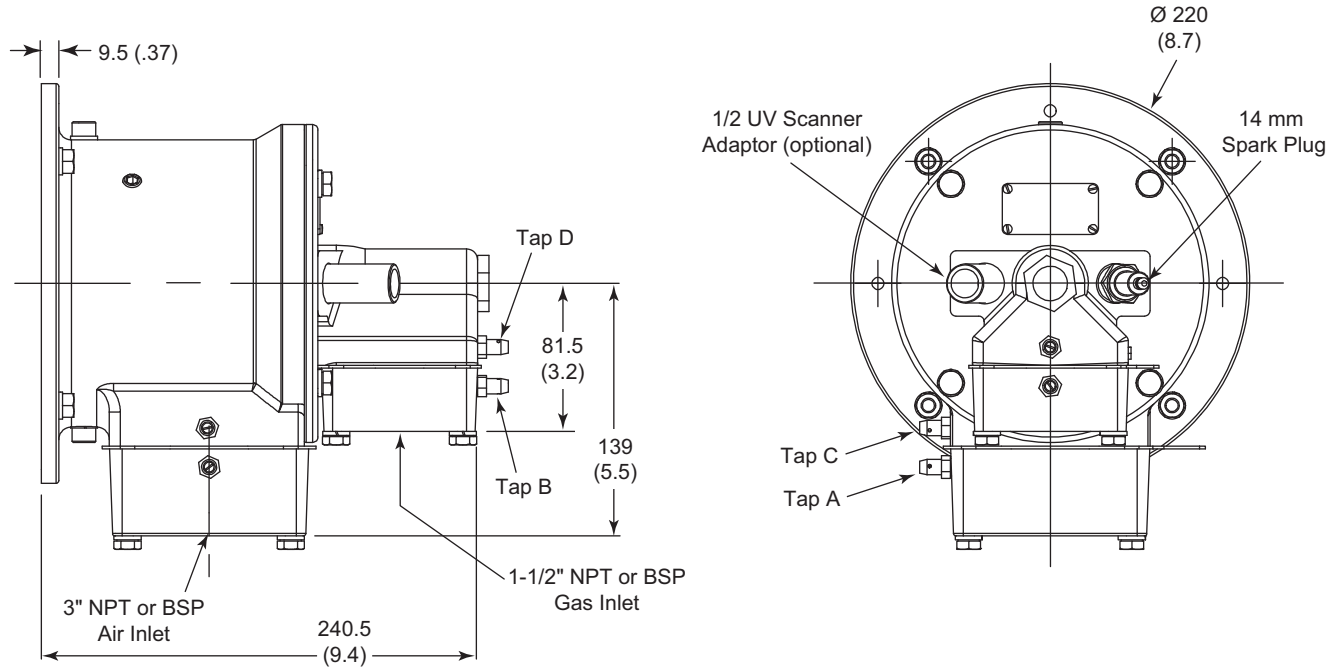

Burner Weight Less Block 19 kg (42 lbs)

Block and Holder

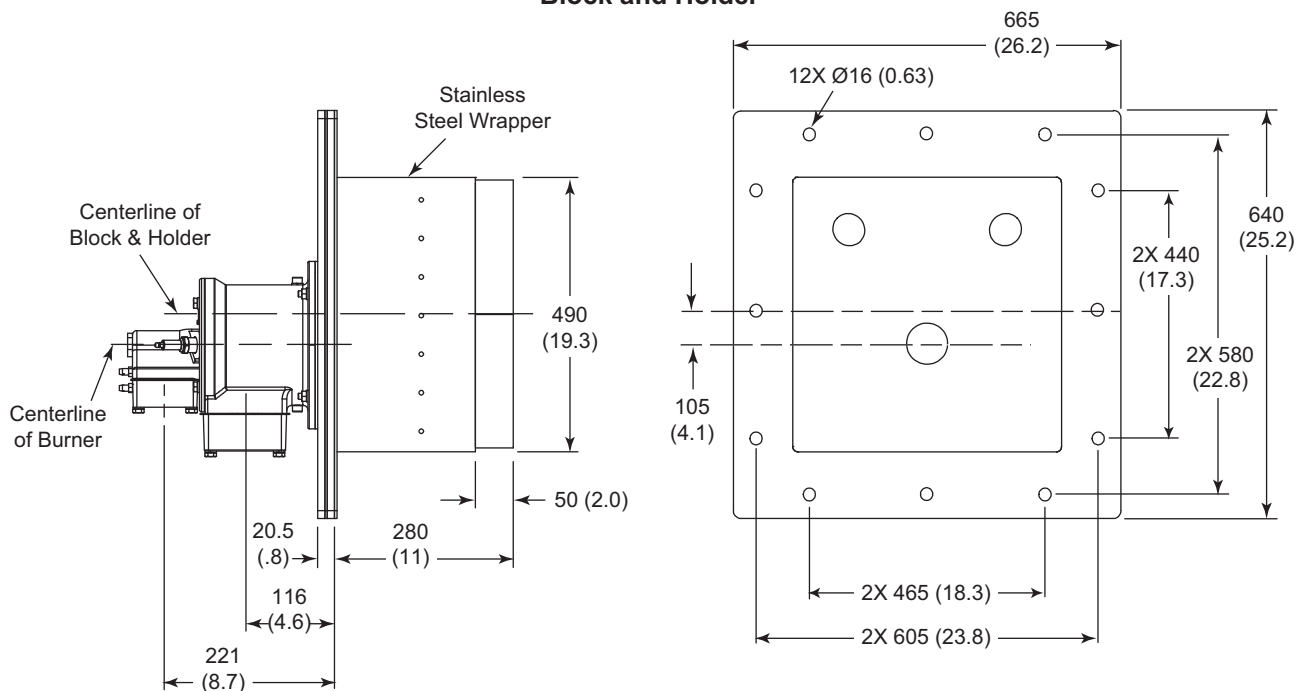

Block & Holder Weight 256 kg (565 lbs)

