

Eclipse WTPU

Throughport Oil Burners

Version 1

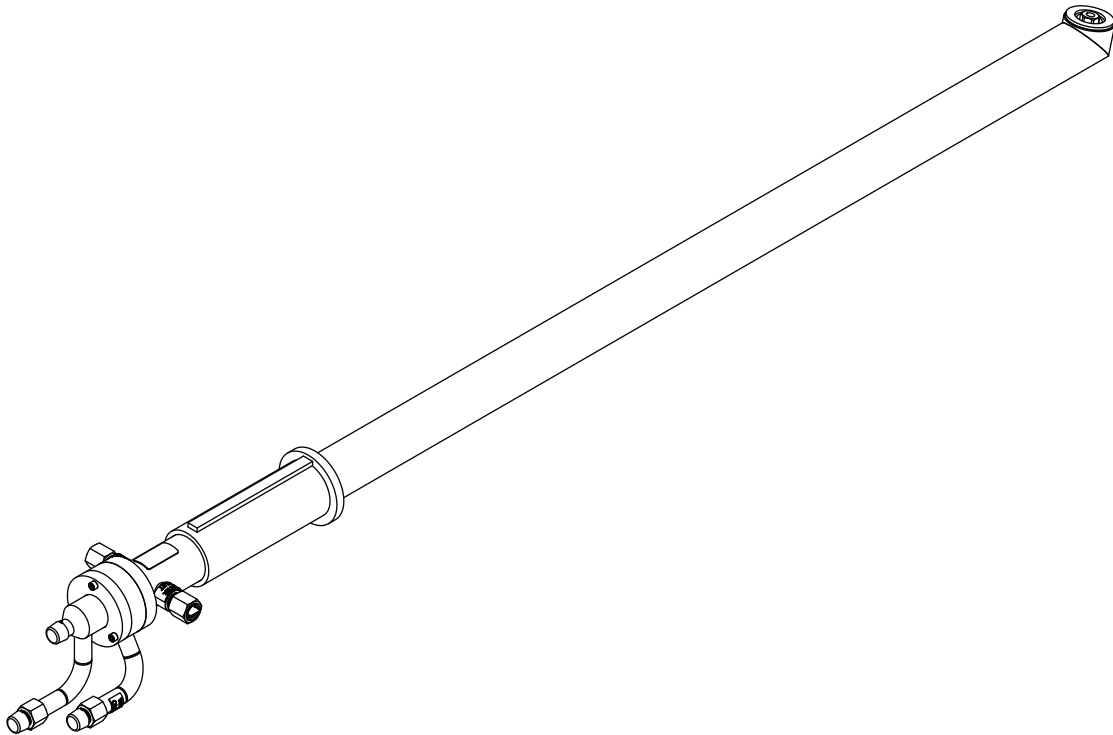

Copyright

Copyright 2013 by Eclipse, inc. All rights reserved worldwide. This publication is protected by federal regulation and shall not be copied, distributed, transmitted, transcribed or translated into any human or computer language, in any form or by any means, to any third parties, without the express written consent of Eclipse, inc.

Disclaimer Notice

In accordance with the manufacturer's policy of continual product improvement, the product presented in this brochure is subject to change without notice or obligation.

The material in this manual is believed adequate for the intended use of the product. If the product is used for purposes other than those specified herein, confirmation of validity and suitability must be obtained. Eclipse warrants that the product itself does not infringe upon any United States patents. No further warranty is expressed or implied.

Liability & Warranty

We have made every effort to make this manual as accurate and complete as possible. Should you find errors or omissions, please bring them to our attention so that we may correct them. In this way we hope to improve our product documentation for the benefit of our customers. Please send your corrections and comments to our Technical Documentation Specialist.

It must be understood that Eclipse's liability for its product, whether due to breach of warranty, negligence, strict liability, or otherwise is limited to the furnishing of replacement parts and Eclipse will not be liable for any other injury, loss, damage or expenses, whether direct or consequential, including but not limited to loss of use,

income, or damage to material arising in connection with the sale, installation, use of, inability to use, or the repair or replacement of Eclipse's products.

Any operation expressly prohibited in this manual, any adjustment, or assembly procedures not recommended or authorized in these instructions shall void the warranty.

Document Conventions

There are several special symbols in this document. You must know their meaning and importance.

The explanation of these symbols follows below. Please read it thoroughly.

How To Get Help

If you need help, contact your local Eclipse representative. You can also contact Eclipse at:

1665 Elmwood Rd.
Rockford, Illinois 61103 U.S.A.
Phone: 815-877-3031
Fax: 815-877-3336
<http://www.eclipsenet.com>

Please have the information on the product label available when contacting the factory so we may better serve you.

 ECLIPSE <small>Innovative Thermal Solutions</small>	www.eclipsenet.com
Product Name	
Item #	
S/N	
DD MMM YYYY	



This is the safety alert symbol. It is used to alert you to potential personal injunt hazards. Obey all safety messages that follow this symbol to avoid possible injury or death.



Indicates a hazardous situation which, if not avoided, will result in death or serious injury.



Indicates a hazardous situation which, if not avoided, could result in death or serious injury.



Indicates a hazardous situation which, if not avoided, could result in minor or moderate injury.

NOTICE

Is used to address practices not related to personal injury.

NOTE

Indicates an important part of text. Read thoroughly.



Table of Contents

Introduction	4
Product Description	4
Benefits	4
Audience	4
WTPU Documents	4
Purpose	4
Safety	5
Capabilities	5
Operator Training	5
Replacement Parts	5
Installation	6
Handling & Storage	6
Approval of Components	6
WTPU Water-Cooled Throughport Oil Burner	7
Burner Cooling Water System	7
Typical Closed-Loop Water System Description	7
Retractable Burner Systems for Eclipse-Supplied Retraction Mechanism	7
Retraction Gear Installation	8
Burner Installation and Operation	9
Maintenance	10
Periodic Checklist	10
Monthly Checklist	10
Yearly Checklist	10
Instructions for Cleaning	10
Removal of the Pneumatic Cylinder for Eclipse-Supplied Retraction Mechanisms	11
Appendix	i
Notes	ii

Introduction

1

Product Description

The WTPU burner is a compact, water-cooled, oil-fired burner designed to be inserted into the port neck of a regenerative glass furnace. The burner can be inserted through the side or bottom of the port neck.

These burners, each incorporating its own water jacket, are of all-welded construction and made from carbon steel. The burner produces a conical flame using a high efficiency atomizer. The atomizing medium may be air, gas or steam. There can be one, two, or three burners in each port. The burner can be used in both end and side fired regenerative furnaces.

Installing the burner under the port, inserted through the port bottom and fitted to the Eclipse retraction mechanism is the optimum arrangement. Using throughport burners with the retraction mechanism ensures the lowest possible maintenance and therefore consistency of combustion, essential for high glass quality.

Benefits

- Reduced fuel consumption
- Refractory cost savings
- Reduced batch carryover
- Reduced burner cleaning giving more consistent performance
- High glass quality
- Low atomizing medium consumption
- Compact burner and water jacket design
- Suitable for all grades of oil with viscosities up to 160 SSU (30 cSt)
- Atomizing air, steam or gas.

Audience

This manual has been written for people who are already familiar with all aspects of a glass burner and its add-on components, also referred to as “the burner system”.

These aspects are:

- Installation
- Use
- Maintenance

The audience is expected to have previous experience with this type of equipment.

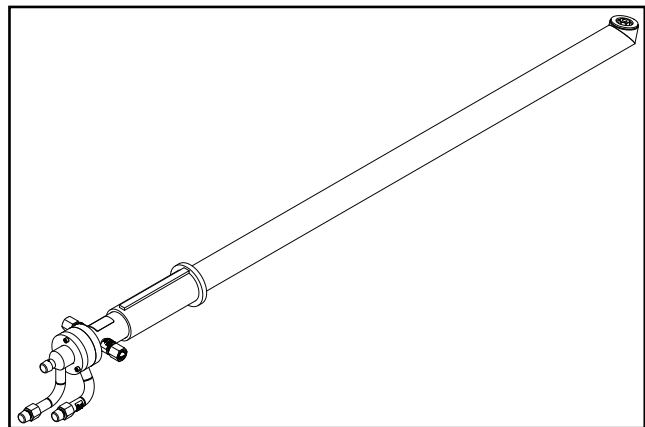

Figure 1.1. WTPU Burner

WTPU Documents

Information Guide 1141-4

- This document

Datasheet 1141-4

- Required to complete design and selection

Spare Parts List 1141-4

- Recommended replacement part information

Related Documents

- EFE 825 (Combustion Engineering Guide)
- Eclipse Bulletins and Info Guides: 710, 732, 760, 818, 830, 832, 852, 854, 856, 610, 820, 902, 930

Purpose

The purpose of this manual is to ensure the installation and adjustment of a safe, effective and trouble-free combustion system.

Safety

2

Important notices, which help provide safe burner operation, will be found in this section. To avoid personal injury and damage to the property or facility, the following warnings must be observed. All involved personnel should read this entire manual carefully before attempting to start or operate this system. If any part of the information in this manual is not understood, contact Eclipse before continuing.



WARNING

- **DO NOT** disassemble any component **WITHOUT** first reading the manufacturer's instructions. Several components contain parts under compression or pressure and could injure personnel if not disassembled properly.
- Control panels contain voltages which can severely injure personnel. These panels are normally double fed from the emergency supply. **NO** engineer/maintenance technician who is not fully conversant with the equipment should be allowed access to the panel internals.
- Control circuits **MUST** not be altered at any time unless Eclipse has been consulted and has approved the modifications.
- No naked lights are to be used in the area of gas pipeline components.
- Any gas leaks should always be isolated and rectified immediately. Any piece of pipeline equipment and its surrounding area should be properly vented and/or purged as appropriate after isolation and before the start of any maintenance.
- Extreme care should be taken when working on burner equipment installed under the furnace port.
- Eclipse recommends installing a safety guard around moving parts.
- Eclipse recommends considering any area with moving mechanical parts a restricted area.
- The burners, described herein, are designed to mix fuel with air and burn the resulting mixture. All fuel burning devices are capable of producing fires and

explosions if improperly applied, installed, adjusted, controlled or maintained.

- **Do not bypass any safety feature; fire or explosion could result.**
- **Never try to light a burner if it shows signs of damage or malfunction.**
- **The burner and duct sections are likely to have HOT surfaces. Always wear the appropriate protective equipment when approaching the burner.**

NOTICE

- This manual provides information regarding the use of these burners for their specific design purpose. Do not deviate from any instructions or application limits described herein without written approval from Eclipse.

Capabilities

Only qualified personnel, with sufficient mechanical aptitude and experience with combustion equipment, should adjust, maintain or troubleshoot any mechanical or electrical part of this system.

Operator Training

The best safety precaution is an alert and trained operator. Train new operators thoroughly and have them demonstrate an adequate understanding of the equipment and its operation. A regular retraining schedule should be administered to ensure operators maintain a high degree of proficiency.

Replacement Parts

Order replacement parts from Eclipse only. All Eclipse approved valves or switches should carry UL, FM, CSA, CGA and/or CE approval where applicable.

Installation

3

In this section you will find information and instructions needed to install the burner and the system components.

Handling & Storage

Handling

- Make sure the area is clean.
- Protect all components from weather, damage, dirt and moisture.
- Protect the components from excessive temperatures and humidity.
- Take care not to drop or damage components.

Storage

- Make sure the components are clean and free of damage.
- Store the components in a cool, clean, dry room.
- After you have made sure everything is present and in good condition, keep the components in their original packaging as long as possible

Approval of Components

Limit Controls & Safety Equipment

All limit controls and safety equipment must comply with all applicable local codes and/or standards and must be listed for combustion safety by an independent testing agency. Typical application examples include:

- American: NFPA 86 with listing marks from UL, FM, CSA
- European: EN 746-2 with CE mark from TuV, Gastec, Advantica

Electrical Wiring

All the electrical wiring must comply with all applicable local codes and/or standards such as:

- NFPA Standard 70
- IEC60364
- CSA C22
- BS7671

Gas Piping

All the gas piping must comply with all applicable local codes and/or standards such as:

- NFPA Standard 54
- ANSI Z223
- EN 746-2

Where to Get the Standards:

The NFPA Standards are available from:
National Fire Protection Agency
Batterymarch Park
Quincy, MA 02269
www.nfpa.org

The ANSI Standards are available from:
American National Standard Institute
1430 Broadway
New York, NY 10018
www.ansi.org

The UL Standards are available from:
333 Pfingsten Road
Northbrook, IL 60062
www.ul.com

The FM Standards are available from:
1151 Boston-Providence Turnpike
PO Box 9102
Norwood, MA 02062
www.fmglobal.com/approvals

Information on the EN standards and where to get them is available from:
Comité Européen de Normalisation
Stassartstraat 36
B-1050 Brussels
Phone: +32-25196811
Fax: +32-25196819
www.cen.eu

Comité Européen de Normalisation Electronique
Stassartstraat 36
B-1050 Brussels
Phone: +32-25196871
Fax: +32-25196919
www.cenelec.org

WTPU Water-Cooled Throughport Oil Burner

This water jacket has a 2.5" (63.5 mm) diameter outer tube and consists of two concentric inner tubes forming an in and out passage for the water. The collar of the burner clamp has a 3" (76.2 mm) outer diameter.

The water jacket is available in lengths of 55" to 79" (1400 mm to 2000 mm) in increments of 4" (100 mm) and in firing angles of 5° to 20° in increments of 5°.

On this style of burner, the water jacket determines the firing angle. Therefore, burner length and firing angle must be determined from furnace information.

Burner Cooling Water System

Eclipse throughport burners require a constant, non-interruptible supply of cooling water. The cooling water requirements are:

Supply Pressure	29 psig (2 barg)
Flow Rate per Burner	11.9 US gal/min (45 L/min) minimum
Pressure Drop through the Burner	9.4 psig (0.65 bar)
Maximum Water Outlet Temperature	140°F (60°C)

The cooling water should be free of impurities and have a maximum water hardness of 30 ppm. Water pH should be between 7.5 and 8.5 with a dissolved oxygen level of less than 1 ppm. Eclipse recommends a closed loop cooling water system, however, where this is impossible, a corrosion inhibitor must be added to the water.

Typical Closed-Loop Water System Description

In a typical closed loop system, water would be stored in a header tank at a constant level. This tank would have a minimum capacity of around 165 US gallons (750 liters) per burner to provide sufficient backup in an emergency situation (approximately 15 minute supply). Water from this header tank would be pumped around the system through heat exchangers, or another type of water cooling device, through the burners (piped in parallel) and back to the pump suction. A pressure switch would be used to check system delivery pressure.

In the event of low pressure being detected, an alarm condition would be registered. Immediate action would need to be taken to avoid possible heat damage to the burners. In a typical Eclipse closed loop system, a standby pump would be brought into use. If this did not restore

correct pressure, bypass valves would operate allowing the header tank water to drain through the burners keeping them cool while they were removed from the furnace.

Similarly, a switching thermometer would be used to check the system return water temperature. If an excessively high temperature was measured again, an alarm condition would be registered requiring immediate action to avoid possible heat damage to the burners. In a typical Eclipse approved system, a standby heat exchanger or water cooler would be brought on-line, and if normal return water temperature was not restored, the system bypass valves would operate to drain the header tank through the burners keeping them cool while they were being removed from the furnace.

On each leg of the burner outlet it is recommended that an orifice plate, fitted with a differential pressure switch, be used to detect individual burner cooling water flow. Each pressure switch would cause an alarm condition warning furnace operators of a potential burner failure if water flow dropped below the minimum. Additional thermometers could also be fitted to each burner leg to give furnace operators extra warning of possible overheating. Pressure gauges would also be fitted at suitable points throughout the system to provide local indication of system conditions.

Contact Eclipse for assistance with water system design.

Retractable Burner Systems for Eclipse-Supplied Retraction Mechanisms

Unit Requirements

1. Pneumatic power air supply. (This supply should be well lubricated using the lubricator provided or using the client's own system).

Supply Pressure	45 psig (3.1 barg) minimum
Air Consumption	25 in ³ /stroke (635 cm ³ /stroke)
Recommended Lubrication Oils	Only mineral based hydraulic oils should be used

2. Retraction gear reversal valve signal line. Required to raise or retract the retraction gear.

Supply On	Burner Raise
Supply Off	Burner Lower
Supply Pressure	45 psig (3.1 barg) minimum

Retraction Gear Installation

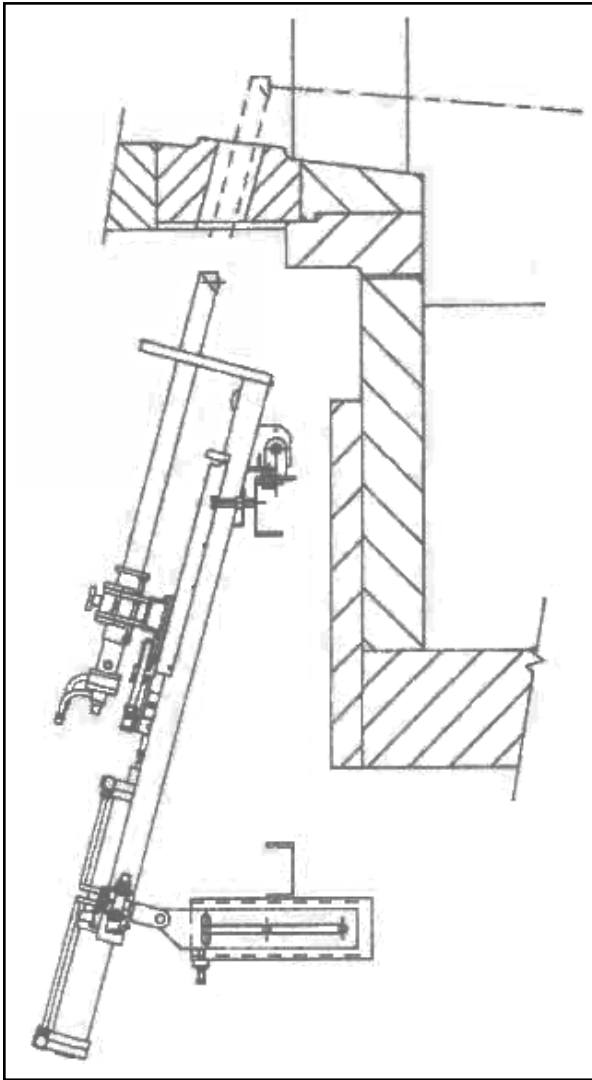

Figure 3.1. Typical Burner Installation

1. Install the retraction gear in approximate position.
2. Attach the power air supply and pilot air signal to the spool valve. Ensure sufficient flexibility is allowed on the pneumatic line for adjustment of the burner alignment and the angular adjustment [approximate minimum $\pm 2"$ (50 mm) in all directions].
3. Check that the gear is clear of all obstructions and that it operates up and down very slowly (speed adjustment by means of the throttle valves on the exhaust ports of the retraction gear reversal valve). Check that the operation of the fuel, atomizing air, and water lines are all correct. Check that the operation of the shut-off valves is correct and that the carrier plate moves up and down freely.

4. Fit a tube of appropriate length and diameter into the burner clamps and check the alignment of the gear with the hole in the port, using top support adjustments to centralize the burner in the hole while it is in the up position. Adjust the angle of the burner using the bottom adjustment with the burner in both the up and the down position. Check and readjust the top centralizing adjustment after any angular adjustment.

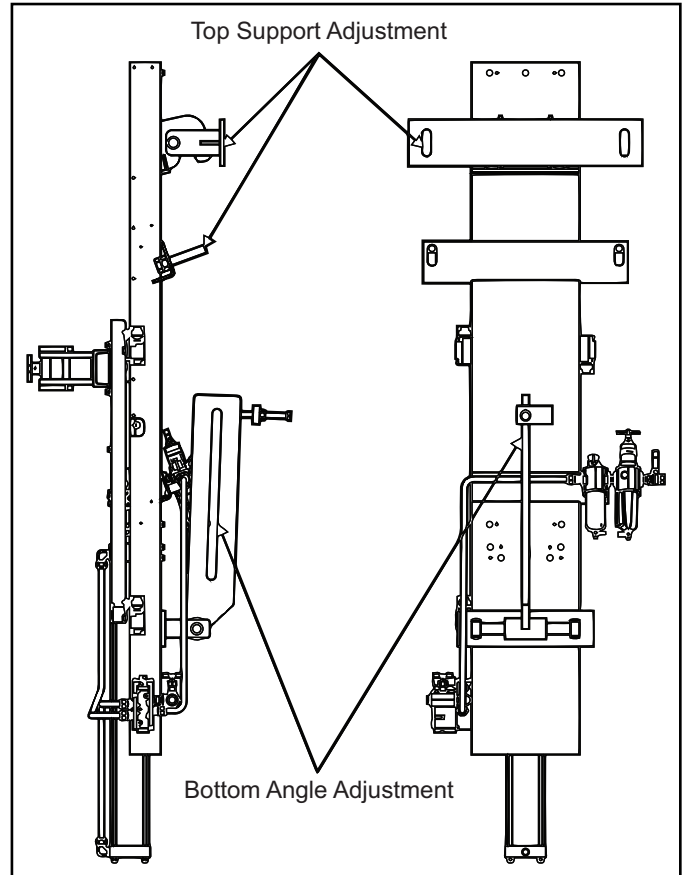

Figure 3.2.

5. Set the pneumatic system pressure to 45 psig (3.1 barg) minimum.
6. Operate the retraction system at normal speed (4-6 seconds/stroke maximum) to check that the movement is smooth and consistent. (This should involve at least 20 strokes).
7. Connect the cooling water supply (see "Burner Cooling Water System" write-up on page 7) ensuring the unused water connections on the burner are securely plugged. Turn on water. Check water alarms.
8. Check water flow is NOT LESS than US 11.9 gal/min (45 L/min).
9. Invert the burner three or four times to ensure no air bubbles are trapped in the water passages.

NOTICE

- **Before starting the burner system and inserting it into the furnace, double check that the water valve is open and that water is circulating through the burner.**

Burner Installation and Operation

1. Ensure the burner is fitted with the correct nozzle kit for the desired flow rate. Notches are machined into the nozzle choke and nozzle swirler to indicate the flow rate. See Figures 3.3 and 3.4.
2. Remove the tube from the clamps and install the burner into the retraction gear at approximately the correct height.
3. Ensure that all fuel isolating valves are closed and that all valves are installed in the proper location and correctly oriented relative to the flow direction.
4. Fit the fuel supply, water supply, and atomizing supply lines to the burner ensuring sufficient flexibility to allow adjustment of the retraction gear. Check that they will move freely and clear any obstruction as the burner moves up and down. No kinking of hoses should occur and the bending radius should not be less than 12 inches (300 mm)
5. Ensure all personnel are clear of the retraction gear.
6. Unlock the pneumatic controls and raise the burner to the firing position.
7. Once the burner is inserted fully into the port, open the atomizing valves.
8. Open the fuel valves.
9. Observe the flame, and set the fuel and atomizing flows to the desired rates.
10. When firing consistently at the appropriate rate, check the burner height and angle. Allow the flame to clear the port refractories. Adjust as necessary.
11. The flame should sweep across the glass surface but not impinge on the glass.
12. Check the appearance of the burner water jacket when it is retracted to ensure no hot spots have occurred.
13. Remove all burners after the first eight hours. Inspect the jackets and clean the nozzles with a soft wire brush.

14. Dedicated cooling air to the limit switches can help limit switch performance and life span.

NOTE: All adjustments should be made with the gear locked in the down position. Any angular adjustments may require re-centralizing of the burner.

NOTE: It is possible to install this type of burner while the furnace is still in operation by drilling the necessary holes in the port bottom. This may be useful in situations where the existing burner system is unsatisfactory or conversion to oil is required.

NOTE: An extractor purge valve must be used with this burner to remove oil from the nozzle after firing.

NOTE: All connections to and from the burner should be secure and free of leaks. However, it is important that overtightening be avoided and, where specified, recommended torque settings be observed.

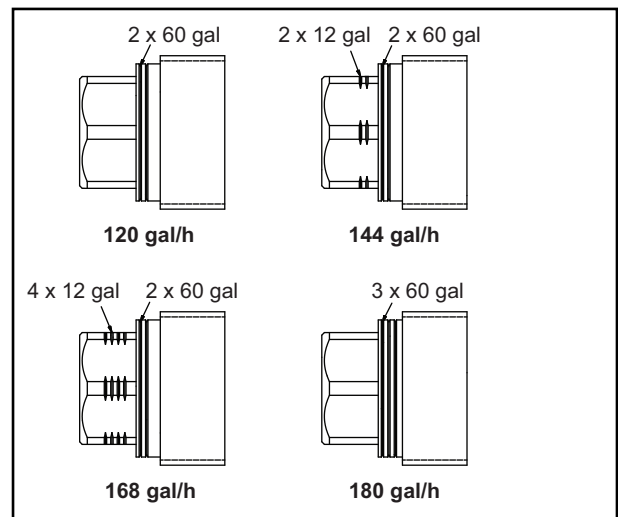

Figure 3.3. Nozzle ID

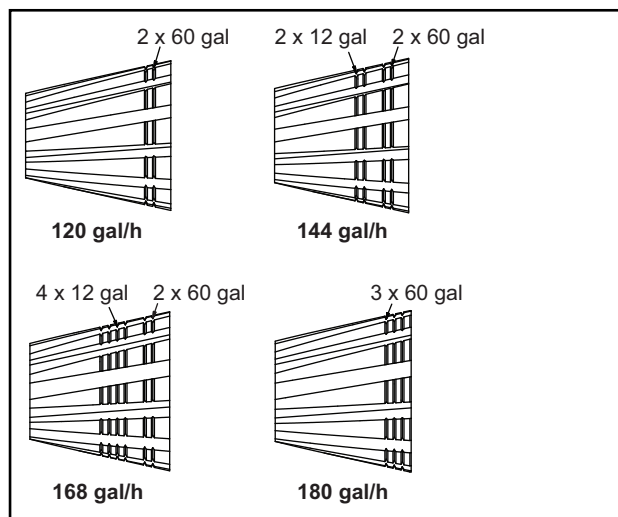

Figure 3.4. Swirler ID

Preventative maintenance is the key to a reliable, safe and efficient system. The following are suggested guidelines for periodic maintenance. Burners in severe environments or operational conditions should be checked more frequently.

NOTE: The periodic, monthly, and yearly lists are an average interval. If your environment is dirty, the intervals may be shorter. Check with local authorities having jurisdiction regarding their recommended maintenance schedules.

Periodic Checklist

1. Continuously monitor the water flow and temperature.
2. Remove and inspect the burners at least four times per year noting hot spots or cracking. Water jackets may need to be chemically cleaned if build-up of deposits is suspected.
3. Before refitting the burners to the furnace, pressure test the water jackets hydraulically to 75 psig (5.2 barg) holding pressure for at least two minutes.
4. Check the operation of the retraction system and the appearance of the burner at least once per day, noting any inconsistency in movement, operation of the shut-off valves or color of the burners, damage hoses, etc.
5. Dismantle and check the water jackets and the water circulation four times per year. Hydraulic pressure test them to 80 psig (5.5 barg).
6. If it should become necessary to replace the retraction gear guide rod wiper rings, care must be taken to replace each bearing block in its original position.

Monthly Checklist

1. Clean all burner nozzles on a routine basis once per month and when required by flame appearance, making sure the burner nozzle is not damaged or distorted.

NOTE: It is likely that more frequent cleaning will be required if using heavy fuel oil.
2. Check for proper air/fuel pressures (refer to the WTPU Datasheet 1141-4).
3. Test all the system alarms for proper response signals.
4. Check the air control valve for smooth, trouble free operation and adjustment.
5. Check for the proper operation of ventilating equipment.
6. Test the manual fuel shut-off valves for proper operation.

Yearly Checklist

1. Test (leak test) safety shut-off valves for tightness of closure.
2. Test pressure switch settings by checking switch movements against pressure settings and comparing these with the actual impulse pressure.
3. Inspect impulse piping for leaks.
4. Clean and inspect all burners.

Instructions for Cleaning

The burner may be dismantled for cleaning purposes after removing the nozzle choke, swirler, pressure plate, and o-ring, (refer to Figure 3.1) by removing three socket headed screws with a 5 mm A/F hexagon wrench, and by removing the fuel inlet section. The water sleeve may be withdrawn to facilitate cleaning. The fuel tube can also be removed. Carefully inspect all internal components for any indication of localized overheating and/or any build-up of scaling or sludge within the water jacket. Ensure that burner internals are thoroughly cleaned of any deposits before reassembly commences. Care should be taken when fitting the inlet section to ensure that the water sleeve is located correctly.

Nozzle

This component is of precision manufacture and should be treated with care.

NOTE: Always replace o-ring seals when the burner has been dismantled to ensure effective sealing on reassembly.

NOTE: O-rings must be of "Viton" grade VA75 to withstand the operating temperatures of the burners. See Spare Parts List 1141-4 for associated part numbers.

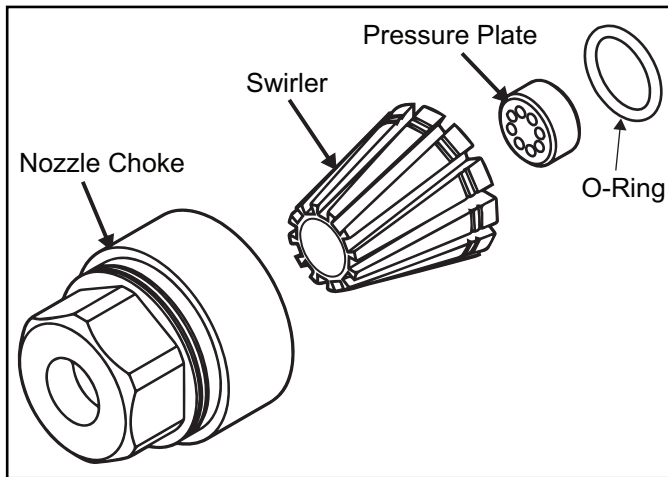

Figure 3.1. Nozzle Kit

Removal of Pneumatic Cylinder for Eclipse-Supplied Retraction Mechanisms

1. Before retraction of the burners, place spacers on the guide rods. These are supplied chained to the unit. The burner carriage can now be lowered down onto the spacers. The spacers support the burner carriage and allow better access to the cylinder link pin.
2. Remove the pin which connects the cylinder rod end to the burner carriage.
3. Remove the connecting pipes to the cylinder.
4. Remove the cylinder. Pivot the block top plate in two positions.
5. It will now be possible to lift the cylinder clear off the retraction gear.
6. Replacement of the cylinder is a reversal of the above procedures. When the cylinder link pin is fitted, ensure that both retaining pins are replaced in their original position.



Appendix

Conversion Factors

Metric to English

From	To	Multiply By
actual cubic meter/h (am ³ /h)	actual cubic foot/h (acfh)	35.31
normal cubic meter/h (Nm ³ /h)	standard cubic foot /h (scfh)	38.04
degrees Celsius (°C)	degrees Fahrenheit (°F)	(°C x 9/5) + 32
kilogram (kg)	pound (lb)	2.205
kilowatt (kW)	Btu/h	3415
meter (m)	foot (ft)	3.281
millibar (mbar)	inches water column ("w.c.)	0.402
millibar (mbar)	pounds/sq in (psi)	14.5 x 10 ⁻³
millimeter (mm)	inch (in)	3.94 x 10 ⁻²
MJ/Nm ³	Btu/ft ³ (standard)	26.86

Metric to Metric

From	To	Multiply By
kiloPascals (kPa)	millibar (mbar)	10
meter (m)	millimeter (mm)	1000
millibar (mbar)	kiloPascals (kPa)	0.1
millimeter (mm)	meter (m)	0.001

English to Metric

From	To	Multiply By
actual cubic foot/h (acfh)	actual cubic meter/h (am ³ /h)	2.832 x 10 ⁻²
standard cubic foot /h (scfh)	normal cubic meter/h (Nm ³ /h)	2.629 x 10 ⁻²
degrees Fahrenheit (°F)	degrees Celsius (°C)	(°F - 32) x 5/9
pound (lb)	kilogram (kg)	0.454
Btu/h	kilowatt (kW)	0.293 x 10 ⁻³
foot (ft)	meter (m)	0.3048
inches water column ("w.c.)	millibar (mbar)	2.489
pounds/sq in (psi)	millibar (mbar)	68.95
inch (in)	millimeter (mm)	25.4
Btu/ft ³ (standard)	MJ/Nm ³	37.2 x 10 ⁻³

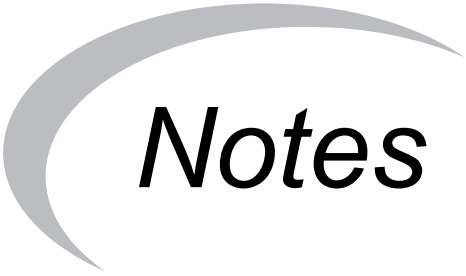

Notes

