

Eclipse Line Burners

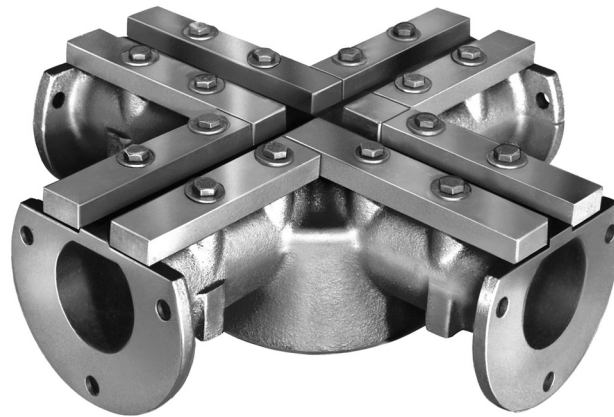

Eclipse Line Burners are premix, retention type burners designed for applications where heat must be distributed over a large area. They are especially suited for oven, kettle, and either recirculating or non-recirculating air heating applications. Several types of line burner sections are available, making a variety of flame patterns possible. Capacities range from 19,000 to 335,000 BTU/hr per lineal foot (based on 70% of required air in premix) depending upon the mixture pressure used.

Assemblies

Eclipse Line Burners are available in 6" and 12" straight sections; side and bottom inlet straight sections; bottom inlet crosses and tees; and 6" 90-degree elbows. Each line burner section is supplied with the nuts and bolts necessary for assembly. In some cases, factory assembly is available. When selecting Line Burners for a system, the total port area must not exceed the cross sectional area of the mixture inlets. Based on a 70% premix using natural gas, the total capacity of the ports should not exceed 385,000 BTU/hr for each 2" mixture inlet or 850,000 BTU/hr for each 3" mixture inlet. Accessory flanges to aid in piping and brackets for mounting flame monitoring and piloting equipment to the burners are also available.

Design Features

Eclipse Line Burner bodies are made of cast iron for durability and flanged for easy assembly. The drilled ports and steel retention lips provide flame stability with mixture pressures up to 30" w.c. and velocities past the burner up to 3600 fpm (burner firing parallel to the air stream). Maximum ambient temperatures should not exceed 800°F.

Line Burners can fire with rich, neutral or lean mixtures. Suitable air/gas mixtures can be supplied by a variety of Eclipse mixing equipment including: High Pressure Injectors, Bulletin 650; Low Pressure Proportional Mixers, Bulletin 652; Vari-Set[®] Mixers, Bulletin 654.

Advantages

- Excellent flame retention
- Wide range of capacities
- Adaptable to many piping arrangements
- Heavy duty construction

Ignition and Flame Monitoring

Reliable ignition from a single point can be provided by using the optional pilot / flame sensor bracket to mount a blast or atmospheric pilot at one end of the burner. A second pilot / flame sensor bracket can be used to mount a flame monitoring device at the opposite end of the burner.



CAUTION

- It is dangerous to use any fuel burning equipment unless it is equipped with suitable flame sensing device(s) and automatic fuel shut-off valve(s). Eclipse can supply such equipment or information on alternate sources.

Dimensions and Capacities

6" x 12" Straight Sections

Top View, L6S

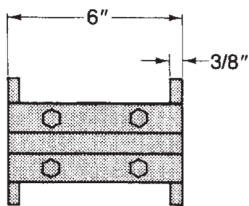

End View, L6S & LS

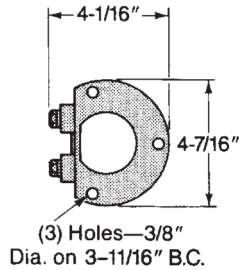

Top View, LS

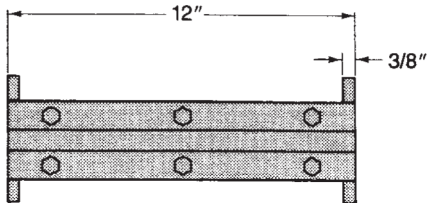

Catalog Number	Assembly Number	Total Port Area Sq. Inches	Capacity on 1000 BTU/hr Based on 70% Total Air Mixture @ Various Mix. Press.			
			2"	4"	6"	8"
6" Straight Section						
0L6S	180136	0.0502	10	14	17	20
1L6S	180027	0.1008	20	28	35	40
2L6S	180028	0.1344	25	38	46	50
3L6S	180029	0.2565	46	66	81	92
4L6S	180030	0.3444	67	91	118	134
5L6S	180031	0.4320	84	121	148	168
12" Straight Section						
0LS	180135	0.1008	19	28	34	40
1LS	180022	0.2016	39	56	69	78
2LS	180023	0.2688	52	75	92	104
3LS	180024	0.5136	92	132	162	184
4LS	180025	0.6888	134	192	236	268
5LS	180026	0.8640	168	241	296	336

12" Bottom Inlet Straight Sections

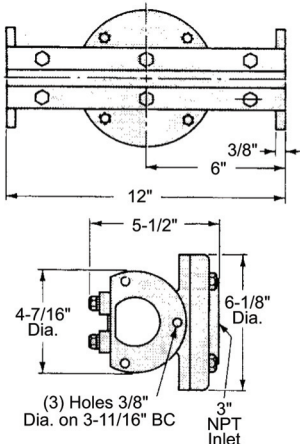

Catalog Number	Assembly Number	Total Port Area Sq. Inches	Capacity on 1000 BTU/hr Based on 70% Total Air Mixture @ Various Mix. Press.			
			2"	4"	6"	8"
0LSB	180141	0.1008	19	28	34	40
1LSB	180052	0.2016	39	56	69	78
2LSB	180053	0.2688	52	75	92	104
3LSB	180054	0.5136	92	132	162	184
4LSB	180055	0.6888	134	192	236	268
5LSB	180056	0.8640	168	241	296	336

12" Side Inlet Straight Sections

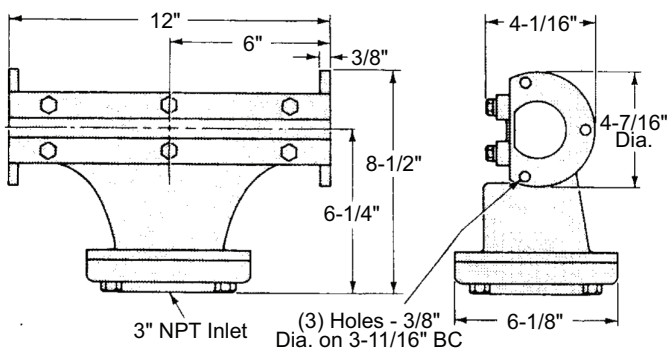

Catalog Number	Assembly Number	Total Port Area Sq. Inches	Capacity on 1000 BTU/hr Based on 70% Total Air Mixture @ Various Mix. Press.			
			2"	4"	6"	8"
0LSS	180140	0.1008	19	28	34	40
1LSS	180047	0.2016	39	56	69	78
2LSS	180048	0.2688	52	75	92	104
3LSS	180049	0.5136	92	132	162	184
4LSS	180050	0.6888	134	192	236	268
5LSS	180051	0.8640	168	241	296	336

12" Side or Bottom Inlet Straight Sections

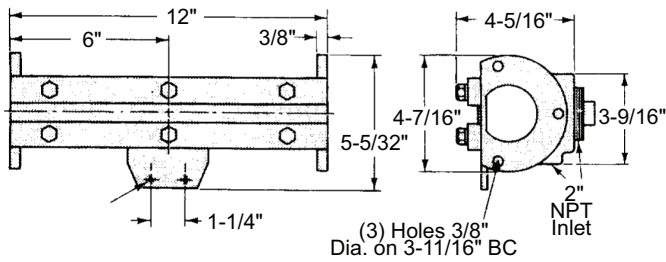

Catalog Number	Assembly Number	Total Port Area Sq. Inches	Capacity on 1000 BTU/hr Based on 70% Total Air Mixture @ Various Mix. Press.			
			2"	4"	6"	8"
1LSBS	180100	0.2016	39	56	69	78
2LSBS	180101	0.2688	52	75	92	104
3LSBS	180102	0.5136	92	132	162	184
4LSBS	180103	0.6888	134	192	236	268
5LSBS	180104	0.8640	168	241	296	336

6" x 6" Flame Elbow

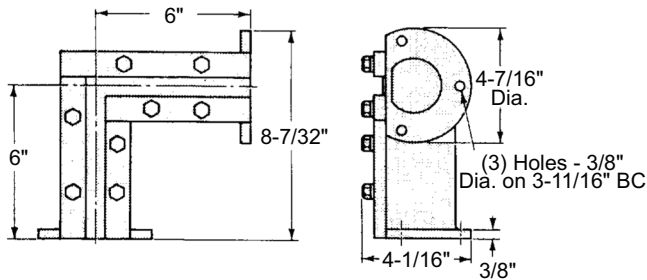

Catalog Number	Assembly Number	Total Port Area Sq. Inches	Capacity on 1000 BTU/hr Based on 70% Total Air Mixture @ Various Mix. Press.			
			2"	4"	6"	8"
0LE	180137	0.1008	19	28	34	40
1LE	180032	0.2016	39	56	69	78
2LE	180033	0.2688	52	75	92	104
3LE	180034	0.5136	92	132	162	184
4LE	180035	0.6888	134	192	236	268
5LE	180036	0.8640	168	241	296	336

12" x 12" Bottom Inlet Flame Cross

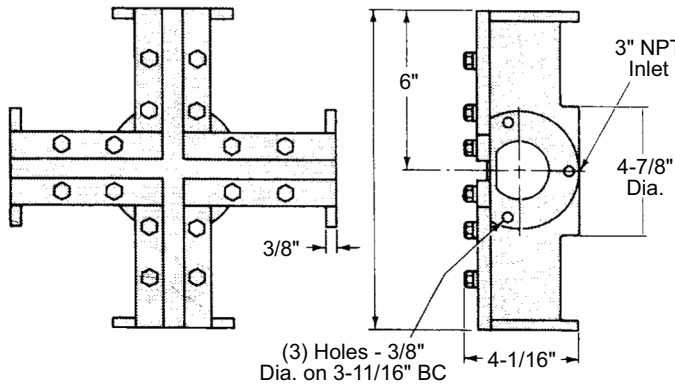

Catalog Number	Assembly Number	Total Port Area Sq. Inches	Capacity on 1000 BTU/hr Based on 70% Total Air Mixture @ Various Mix. Press.			
			2"	4"	6"	8"
0LC	180139	0.2079	37	53	64	75
1LC	180037	0.4158	74	106	129	148
2LC	180038	0.5446	106	152	186	212
3LC	180039	1.0138	196	281	345	392
4LC	180040	1.3496	263	377	463	526
5LC	180041	1.6854	330	472	580	660

12" x 6" Bottom Inlet Flame "T"

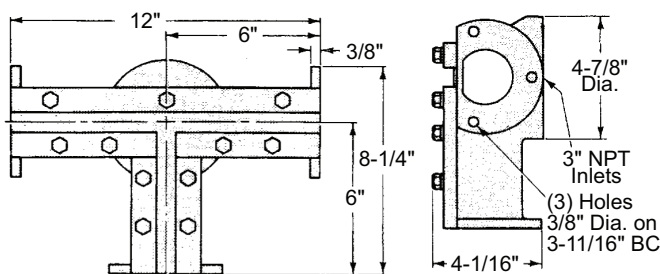

Catalog Number	Assembly Number	Total Port Area Sq. Inches	Capacity on 1000 BTU/hr Based on 70% Total Air Mixture @ Various Mix. Press.			
			2"	4"	6"	8"
0LFT	180138	0.1491	29	41	51	57
1LFT	180042	0.2982	58	83	102	116
2LFT	180043	0.3962	77	110	135	154
3LFT	180044	0.7532	147	210	258	294
4LFT	180045	1.0087	196	280	345	392
5LFT	180046	1.2642	247	353	434	494

Accessories for Line Burners

Expansion Joint — Assembly Number 181014

Eclipse Line Burner Expansion Joints are used in the center of a row of line burners to eliminate the possibility of bowing or buckling due to burner expansion. They are also used to relieve stress on mixture piping when a row of burners is fed by two mixture lines from a common manifold. When an expansion joint is used, it is necessary to have gas / air mixture fed to burners on both sides of the joint as the mixture will not pass through it.

Maximum velocity past the expansion joint should be limited to 3600 fpm and ambient temperature limited to 800°F.

Expansion joints are furnished with number 3 L drillings. Using 70% premix, capacity is 57,000 BTU/hr at 4" w.c. mixture pressure, using natural gas of 0.6 specific gravity.

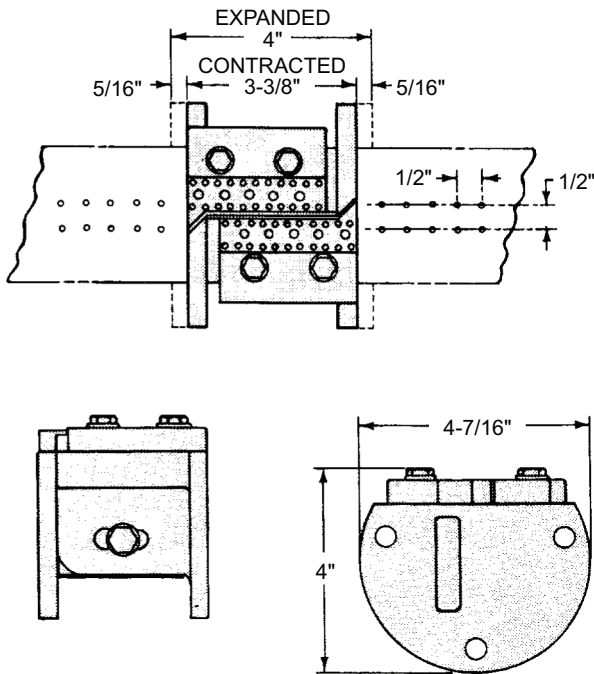

Pilot Section — Assembly Number 180192, Catalog Number 2L6SP

Eclipse Line Burner Pilot Sections are composed of a 6" Eclipse Line Burner, a 131 Pilot Mixer, and a combination ignition electrode and flamerod mounting bracket. The assembly also includes a 6" flamerod and a self-grounding ignition electrode. By simply loosening a nut on the flamerod bracket, the flamerod may be adjusted to obtain the best flame signal output.

Two divider plates are supplied with each pilot section. It is important that these plates are assembled between the pilot section and adjoining burners as the pilot has its own source of gas / air mixture. If the pilot section is to be used at either end of a row of burners, it must be ordered with a plain end flange, assembly number 180006. See "Accessories" section.

The Line Burner Pilot Section is rated at 25,000 BTU/hr at 2" w.c. mixture pressure and with 70% of required air through the mixer. When ordering, be sure to specify jet size required or air pressure available to the pilot mixer, as indicated in the following table:

Air Press.	Jet Size
4 oz	9/32
8 oz	7/32
12 oz	6/32
16 oz	6/32

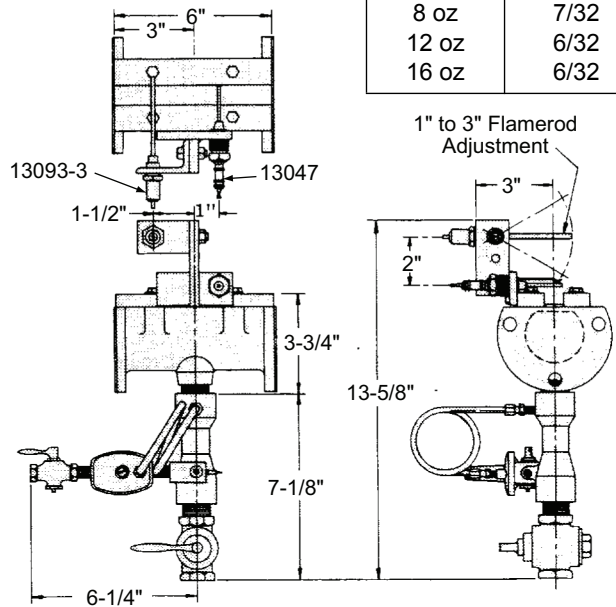

Flanges and Adapters

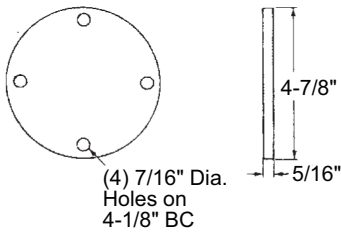

Plain Bottom Flange.
For closing off bottom
inlet on 12 x 12"
CROSS or 12 x 6"
TEE. Assembly number
180007.

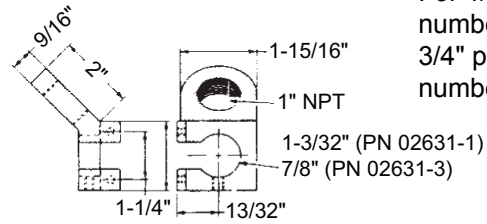

Pilot/Flame Sensor
Mounting Bracket.
For 1/2" pilot. Part
number 2631-3. For
3/4" pilot. Part
number 2631-1.

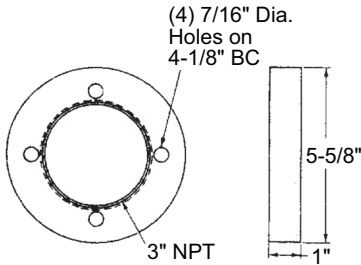

3" Bottom Inlet Flange.
Add to 12 x 12" CROSS
or 12 x 6" TEE when
flanged inlet is desired.
Part number 514-3.

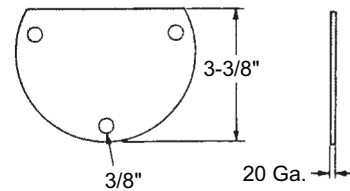

Divider Plate. For
separating zones.
Part number 10591.

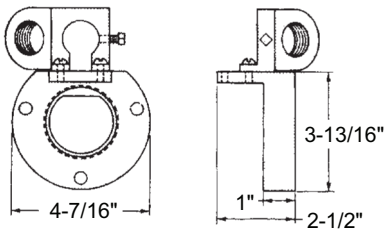

Inlet Flange with
Pilot / Flame Sensor
Mounting Bracket.
For 1-1/2" NPT and
3/4" pilot. Assembly
number 180016. For
2" NPT and 1/2"
pilot. Assembly
number 180017.

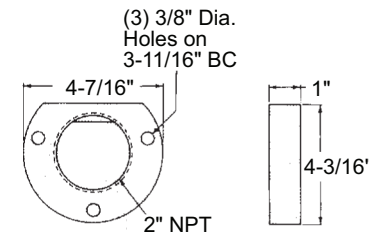

Inlet End Flange.
For 1-1/2" NPT.
Assembly number
180008. For 2"
NPT. Assembly
number 180009.

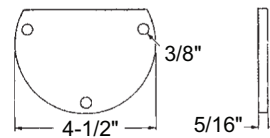

Plain End Flange.
For closing off end
of burner section.
Assembly number
180006.

Typical Line Burner Configurations

