

# Eclipse Tube Firing

## Burner

Model TFB200

Version 2

Parameter		Burner Input 1000's Btu/h (kW)						
		800 (234.3)	1000 (292.8)	1200 (351.4)	1400 (409.9)	1600 (468.5)	1800 (527.1)	2000 (585.6)
<b>Low Firing Rate x 1000 Btu/h (kW)<sup>1</sup></b> <i>At 100% excess air</i>	Without UV Scanner	25 (7.3)	25 (7.3)	25 (7.3)	25 (7.3)	25 (7.3)	25 (7.3)	25 (7.3)
	With UV Scanner	50 (14.6)	50 (14.6)	50 (14.6)	50 (14.6)	50 (14.6)	50 (14.6)	50 (14.6)
<b>Air Inlet Pressure, "w.c. (mbar)<sup>2</sup></b> <i>Measured between Taps A and B (see pages 3 and 4)</i>		5.6 (14.0)	8.8 (21.9)	7.1 (17.7)	6.3 (15.7)	8.3 (20.7)	6.1 (15.2)	7.3 (18.2)
<b>Air Flow, SCFH (Nm<sup>3</sup>/h)</b> <i>At 15% excess air</i>		9200 (260.5)	11500 (325.6)	13800 (390.8)	16100 (455.9)	18400 (521.0)	20700 (586.2)	23000 (651.3)
<b>Differential Gas Pressure, "w.c. (mbar)<sup>3</sup></b> <i>Measured between Taps C and D (see pages 3 and 4)</i>	Natural Gas	3.8 (9.5)	5.9 (14.7)	4.1 (10.2)	3.6 (9.0)	4.8 (12.0)	3.2 (8.0)	4.1 (10.2)
	Propane	3.6 (9.0)	5.6 (14.0)	3.4 (8.5)	2.9 (7.2)	3.7 (9.2)	3.8 (9.5)	4.6 (11.5)
	Butane	2.8 (7.0)	4.4 (11.0)	2.7 (6.7)	2.2 (5.5)	2.9 (7.3)	3.0 (7.5)	3.7 (9.2)
<b>Piping</b>		NPT or BSP burner piping is available						
<b>Flame Detection<sup>4</sup></b>		UV Scanner only						
<b>Ignition</b>		Direct spark ignition (6 kVAC)						
<b>Fuels</b> <i>For any other mixed gas, contact Eclipse, Inc.</i>		Natural gas, propane, butane						
<b>Maximum PCA Temperature, °F (°C)</b>		1000 (540)						
<b>Weight, lbs (kg)<sup>5</sup></b>		41 to 53 (18 to 24)						
<b>Approvals</b>		 AN30						

All inputs based on gross calorific values.

Eclipse reserves the right to change the construction and/or configuration of our products at any time without being obliged to adjust earlier supplies accordingly.

Plumbing of air and gas will affect accuracy of orifice readings. All information is based on generally acceptable air and gas piping practices.

<sup>1</sup> The low firing rate represents the capability of the burner. Achievement of this rate will be affected by the control method and ratio-regulator used in the system design.

<sup>2</sup> Total static air pressure required will be the sum of the differential pressures and the static air pressure, as indicated on pages 3 and 4.

<sup>3</sup> Gas pressures shown are for system sizing only. Provisions must be made to supply fuel pressure, at the burner fuel input port, at least 3" w.c. higher than the differential pressure shown in the tables.

<sup>4</sup> Flame rod not available with preheated combustion air (PCA). Contact Eclipse if PCA and propane/butane will be used in combination.

<sup>5</sup> All weights are approximate.

## Performance Graphs

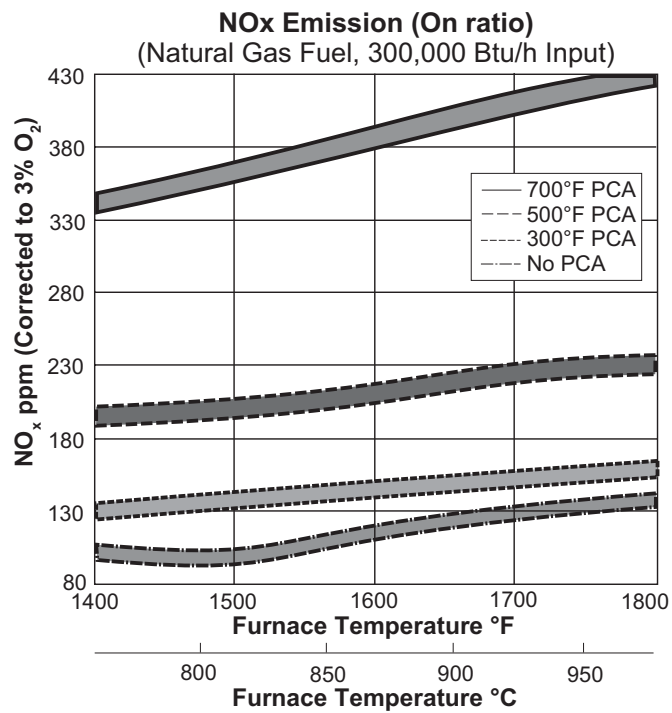
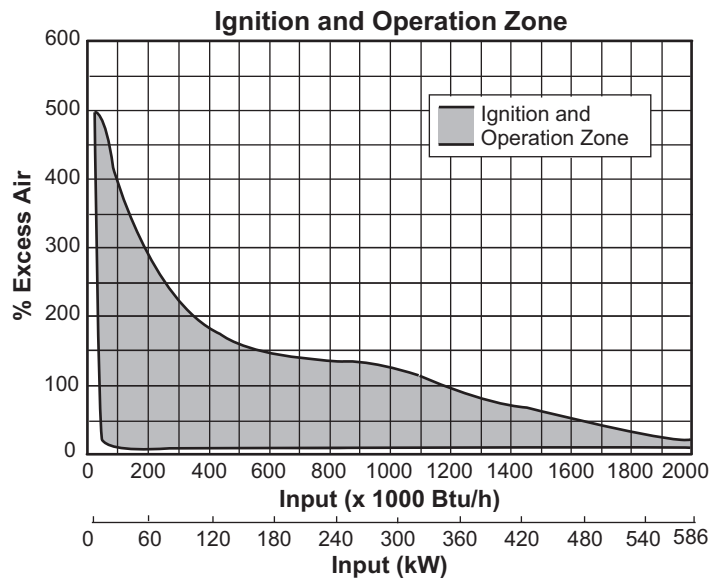

CO emissions are less than 10ppm (corrected to 3% O<sub>2</sub>) for furnace temperatures between 1400°F and 1800°F

Emissions from the burner are influenced by:

- fuel type
- combustion air temperature
- chamber conditions
- percent of excess air

For estimates of other emissions, contact Eclipse Inc.

## Performance Graphs (Continued)

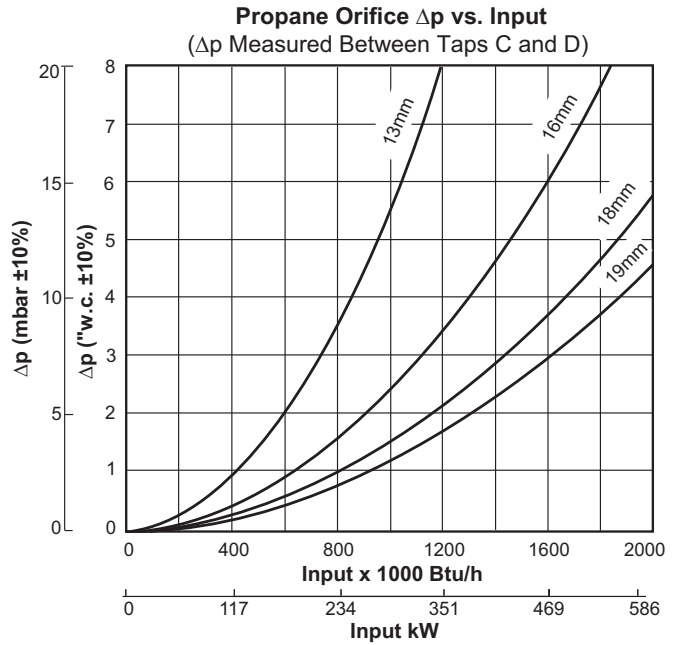
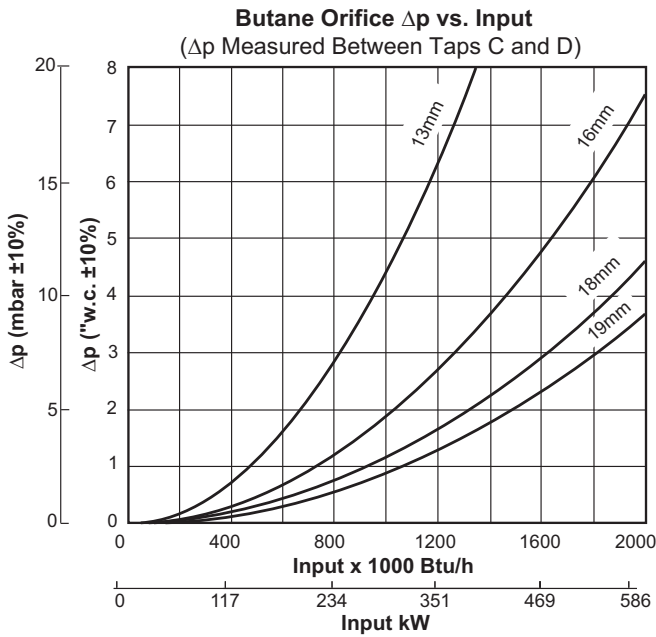
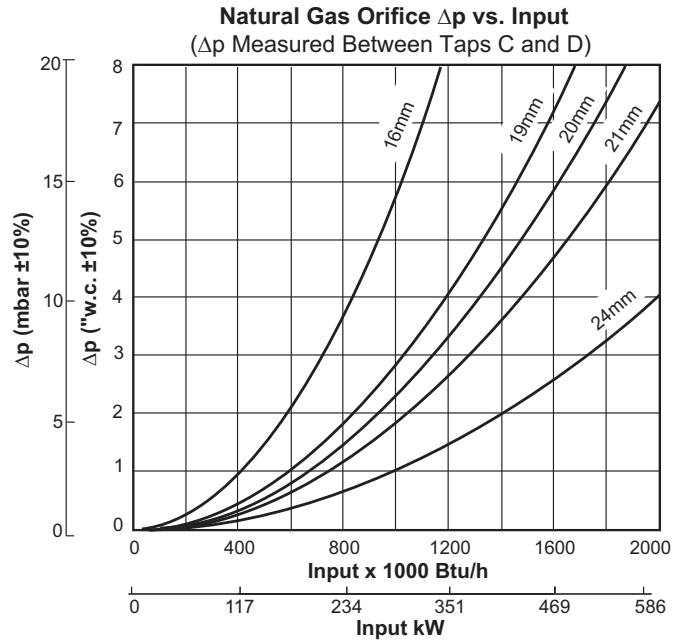
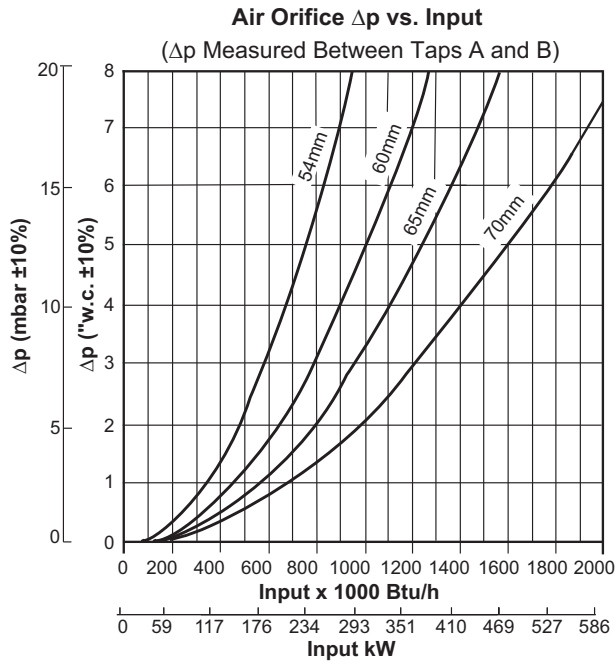

### Static Pressure at the Air Inlet (no air orifice)

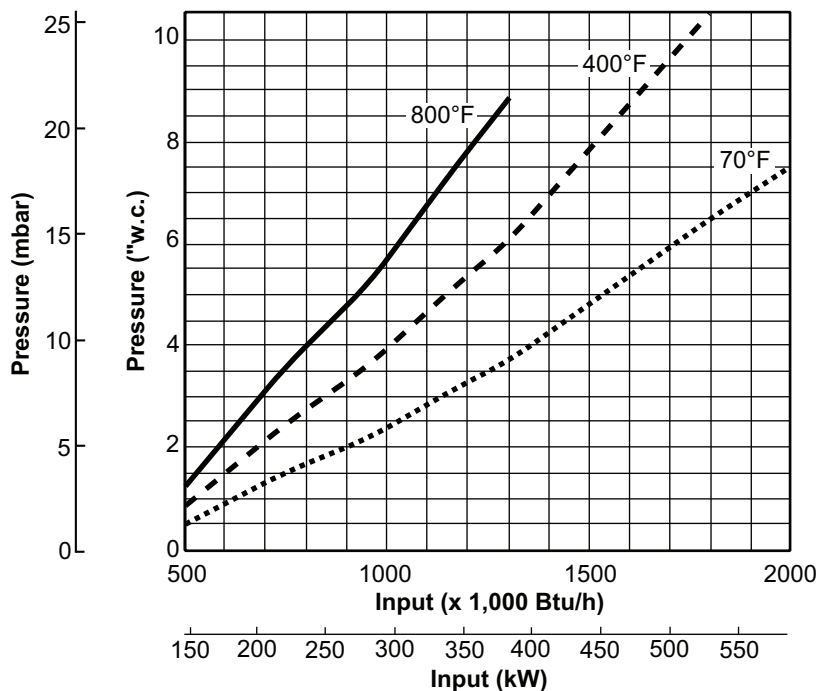

### Dimensions and Specifications

Dimensions in mm (inches)

#### Non-PCA Option

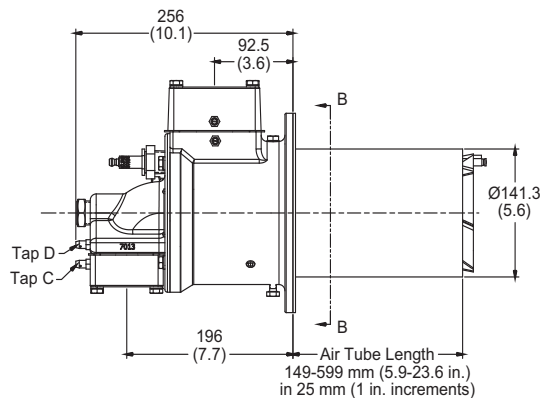
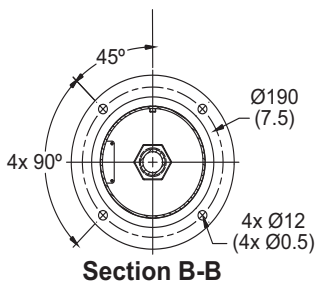
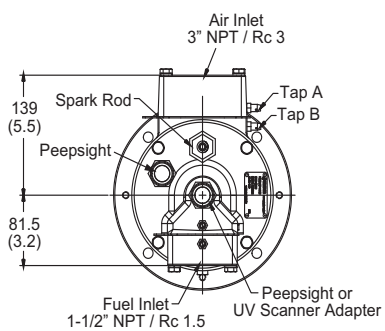

#### PCA Option

(includes tap extensions)

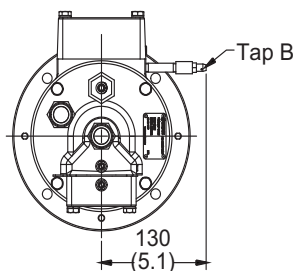

Available air tube lengths are the same as Non-PCA Option

