

Gear motor GT 50

Technical Information · GB

3 Edition 11.14



- Controlled by three-point step signal:
GT 50..E by continuous signal,
GT 50..R by two-point step signal
- Simple commissioning thanks to Automatic/Manual mode changeover
- Position indicator that can be read externally
- Precise setting of the switching positions thanks to infinitely adjustable switching cams
- Installation options for two control elements
- Spacious connection chamber for ease of installation
- Any installation position
- Low-maintenance operation



Contents

Gear motor GT 50	1	7 Technical data	20
Contents	2	7.1 Dimensions	22
1 Application	3	8 Maintenance cycles	23
1.1 Examples of application	5	Feedback	24
1.1.1 Modulating control via three-point step signal	5	Contact	24
1.1.2 Modulating control with continuous input signal	5		
1.1.3 Staged control via two-point step signal	5		
2 Certification	6		
2.1 Eurasian Customs Union	6		
3 Function	7		
3.1 Connection diagrams	8		
3.1.1 GT 50	8		
3.1.2 With continuous control (GT 50..E)	9		
3.1.3 With two-point step control (GT 50..R)	10		
4 Selection	11		
4.1 Selection table	11		
4.1.1 Type code	11		
5 Project planning information	12		
5.1 Electrical cables and wiring	12		
5.2 Feedback potentiometer	12		
5.3 Current sensor	12		
5.4 Installation	13		
6 Accessories	14		
6.1 Attachment set for axial actuator	14		
6.1.1 Dimensions	15		
6.2 Attachment set with linkage	16		
6.2.1 Dimensions	17		
6.3 Heat deflector	18		
6.4 Attachment for foot assembly	19		
6.5 Feedback potentiometer	19		
6.6 Current sensor	19		

1 Application



Gear motor GT 50 is mounted directly onto a butterfly valve, for example, DKR, in order to control the gas and air flow rates on gas burners. It is designed for applications that require precise, controlled rotary movement between 0° and 90° or 0° and 160° .

There are two possible ways of checking the current position of the actuator – either using an optional feedback potentiometer or an optional current sensor. These checking functions can be used in automation processes.

The GT 50 is controlled by a continuous signal or three-point step signal. The Automatic/Manual mode changeover and the position indicator that can be read externally assist in the setting of the infinitely adjustable switching cams upon commissioning. This enables precise settings even in the low-fire rate range.

Gear motor GT 50..U is available with reversed direction of rotation for butterfly valves with stop bars, e.g. DKR..A.



Gear motor GT 50 mounted onto butterfly valve DKR



Roller hearth kiln in the ceramics industry



Forging furnace

1.1 Examples of application

1.1.1 Modulating control via three-point step signal

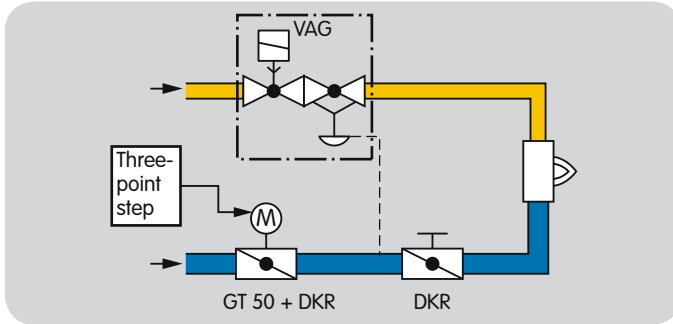

For processes that require high temperature accuracy and low circulation in the furnace. Gear motor GT 50 is controlled by a three-point step controller and moves the butterfly valve DKR to the ignition position. The burner starts. The butterfly valve opens or closes between the low-fire and high-fire rate positions depending on the capacity demand of the burner. When the three-point step signal is disconnected, the butterfly valve stops at its current position.

1.1.2 Modulating control with continuous input signal

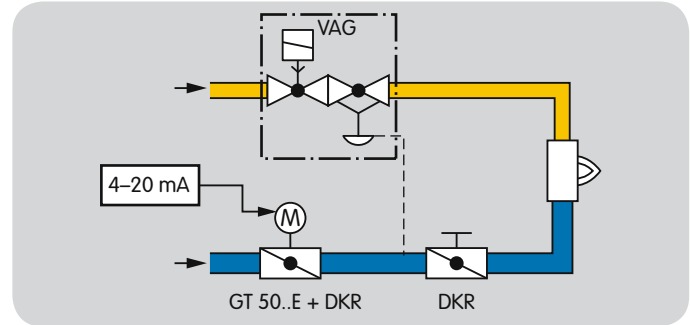

Gear motor GT 50..E is controlled via a 4–20 mA, 0–20 mA or 0–10 V signal.

1.1.3 Staged control via two-point step signal

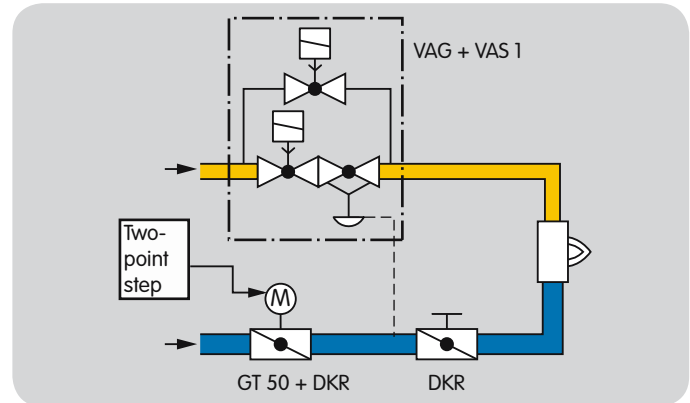

For processes that require a homogeneous temperature distribution in the furnace. Gear motor GT 50 is controlled by a two-point step controller and operates in On/Off or High/Low intermittent mode. The actuator closes when the voltage supply is interrupted.

2 Certification



Gear motor GT 50 is designed for applications pursuant to the Machinery Directive (98/37/EC).

Meets the requirements of the

- Low Voltage Directive (2006/95/EC) on the basis of EN 60730-1,
- Electromagnetic Compatibility Directive (2004/108/EC) on the basis of EN 50082-2 and EN 50081-1.

2.1 Eurasian Customs Union



The product GT 50 meets the technical specifications of the Eurasian Customs Union (the Russian Federation, Belarus, Kazakhstan).

3 Function

Gear motor GT 50 moves a butterfly valve, e.g. DKR, towards 0°, 90° or 160°, if it is actuated electrically by a continuous signal or a three-point step signal. The actuator position can be read from the outside. If the actuator is disconnected from the electrical power supply, it stops the butterfly valve in its current position. A high holding torque when de-energized renders additional braking elements superfluous. Two infinitely adjustable switching cams limit the angle of rotation so as to allow low and high fire to be set individually.

Gear motor GT 50..U has reversed direction of rotation. It is used for butterfly valves with stop bars (e.g. DKR..A). Installing the butterfly valve in a vertical pipe with the direction of flow from bottom to top prevents dirt accumulating on the stop bar and ensures the valve can close tightly.

Automatic/Manual mode

The Automatic/Manual mode changeover of GT 50 and GT 50..E assists in the setting of the infinitely adjustable switching cams upon commissioning. This enables precise settings even in the low-fire rate range.

The switching point is set directly on the cams with an Allen key (enclosed).

Auxiliary switches

External devices can be activated or intermediate positions can be checked via three (or two in the case of GT 50..R) additional, floating, infinitely adjustable switches. There are two possible ways of checking the current position of the actuator – either using an optional feedback potentiometer or an optional current sensor.

3.1 Connection diagrams

3.1.1 GT 50

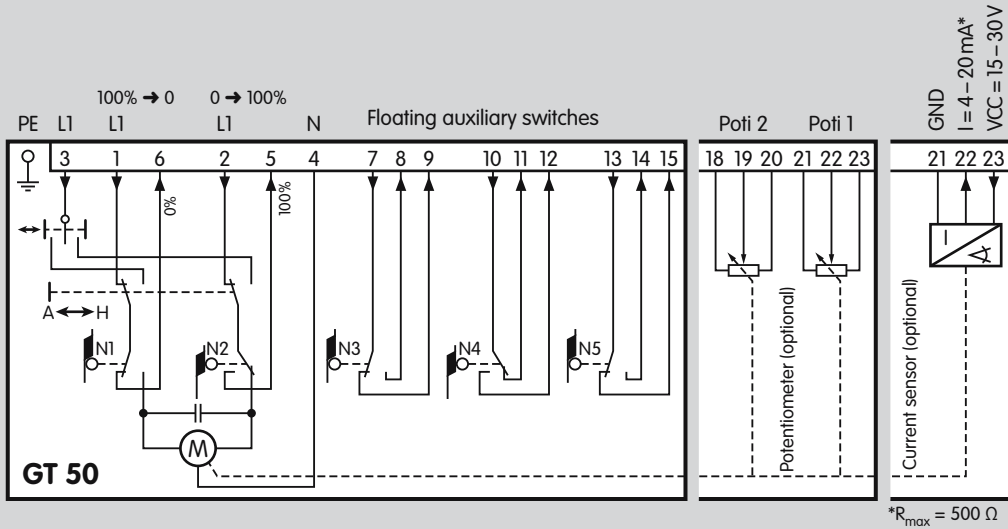

Electrical cables and wiring, see page 12 (Project planning information).

3.1.2 With continuous control (GT 50..E)

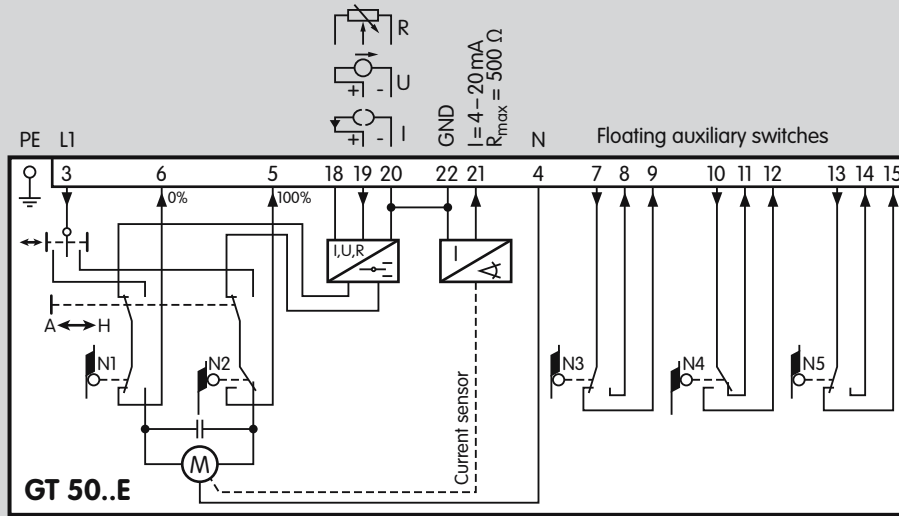

DIP switch

The GT 50 with continuous control is equipped with positioning control. The following input signal types can be set via a DIP switch.

Electrical cables and wiring, see page 12 (Project planning information).

Signal type	Switch position
0–20 mA	
4–20 mA	
0–10 V	
1–135 Ω	

3.1.3 With two-point step control (GT 50..R)

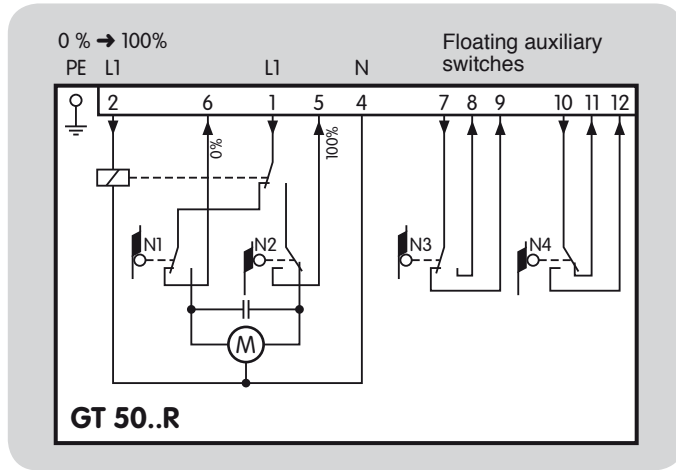

If an input signal is applied to terminal 2, the actuator opens.
If no input signal is applied to terminal 2, the actuator closes.

Electrical cables and wiring, see page 12 (Project planning information).

4 Selection

4.1 Selection table

	-03 to -214	T	M	H	-1 to -20	E ¹⁾	R ¹⁾	G ¹⁾	U ²⁾
GT 50	●	●	●	●	●	○	○	○	●

Order example

GT 50-214M-20G

¹⁾ If "none", this specification is omitted.

²⁾ Only in conjunction with butterfly valve DKR..A.

● = standard, ○ = available

4.1.1 Type code

Code	Description
GT 50	Actuator for butterfly valves
	Running time [s]/Adjustment angle [°]:
-03	3.7/90
-06	6.5/160
-07	7.5/90
-13	13/160
-15	15/90
-27	27/160
-30	30/90
-54	54/160
-60	60/90
-107	107/160
-120	120/90
-214	214/160
T	Mains voltage: 220/240 V AC, 50/60 Hz
M	110/120 V AC, 50/60 Hz
H	24 V AC, 50/60 Hz
	Torque:
-4	3.7 Nm
-7	7.5 Nm
-15	15 Nm
-20	20 Nm
E	Continuous control
R	Two-point control
G	Additional switches with gold contacts
U	Reversed direction of rotation

5 Project planning information

5.1 Electrical cables and wiring

Install supply and signal lines separately.

Cables should be installed well away from high-voltage lines of other devices.

Observe EMC Directive for installation of signal lines.

Use cables with wire end ferrules.

Cable cross-section: max. 2.5 mm², see page 20 (Technical data).

If the power supply is susceptible to frequent voltage peaks we recommend that an electric filter be used.

Electrical wiring, see "Connection diagrams" on page 8 (GT 50), page 9 (With continuous control (GT 50..E)) and page 10 (With two-point step control (GT 50..R)).

5.2 Feedback potentiometer

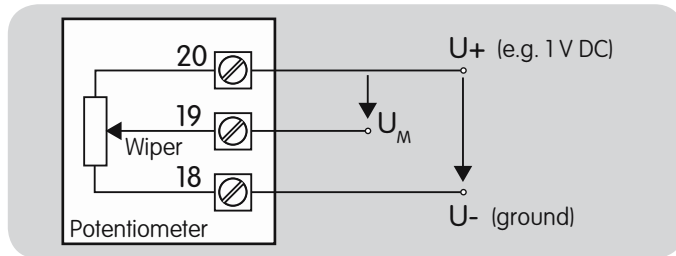

The feedback potentiometer for gear motor GT 50 offers the option of monitoring the current position of the actuator.

It must be utilized as a voltage divider. The change in position of the potentiometer wiper (which corresponds to the actuator position) can be measured as a changing voltage between U₊ und U₋ (ground).

Other circuit layouts produce measurement results that are inaccurate and do not remain stable over a long period of time or are non-reproducible. They also reduce the service life of the feedback potentiometer.

The potentiometer is available as an accessory, see page 14 (Accessories), and is installed at the factory. The potentiometer cannot be retrofitted.

5.3 Current sensor

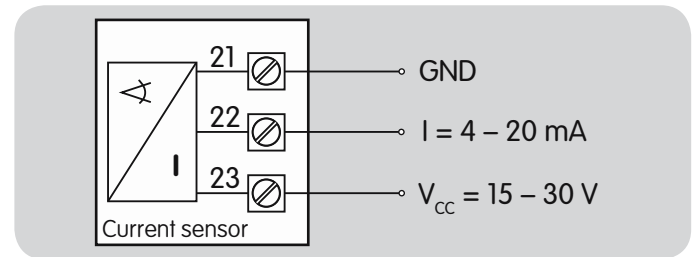

The current sensor for gear motor GT 50 offers the option of monitoring the current position of the actuator.

The current sensor is available as an accessory, see page 14 (Accessories) and is installed at the factory. The current sensor cannot be retrofitted.

5.4 Installation

Installation position: any.

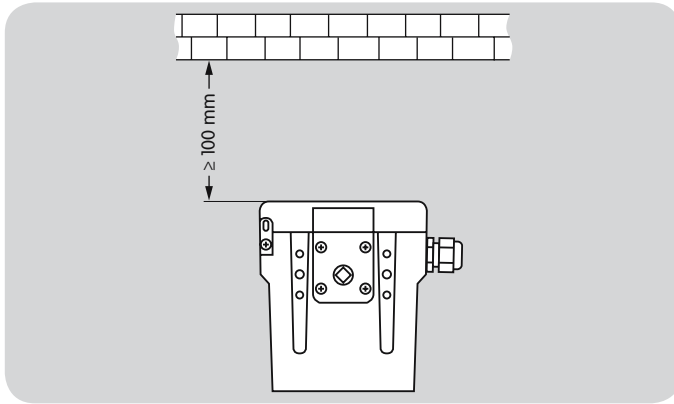

Ensure that there is sufficient space for installation and adjustment.

If the actuator is used with hot air, the pipeline should be adequately insulated so as to reduce the ambient temperature. The ambient temperature on the actuator motor must be $\leq 60^{\circ}\text{C}$.

Important! In order to avoid over-heating, the flanges and butterfly valve must not be insulated.

Install the butterfly valve in such a way that rising hot air does not circulate around the actuator, using the optional attachment set with heat deflector, if required, see page 14 (Accessories). In conjunction with butterfly valve DKR, the actuator can be used in temperatures of up to 250°C or, with additional heat deflectors, it can be used in temperatures of up to 650°C .

6 Accessories

6.1 Attachment set for axial actuator



For axial attachment of a gear motor GT 50..U to a butterfly valve DKR..A. Fitted or enclosed as an additional item on delivery.

For nominal sizes	Order No.		Weight [kg]
	Enclosed	Fitted	
DN 15 – 20	26502150	26502600	1.3
DN 25 – 50	26502160	26502610	1.3
DN 65 – 100	26502170	26502620	1.3
DN 125	26502180	26502630	1.3
DN 150 – 200	26502190	26502640	1.3
DN 250	26502200	26502650	1.3
DN 300	26502210	26502660	1.4
DN 350	26502220	26502670	1.4
DN 400	26502230	26502680	1.4
DN 450 – 500	26502240	26502690	1.4

6.1.1 Dimensions

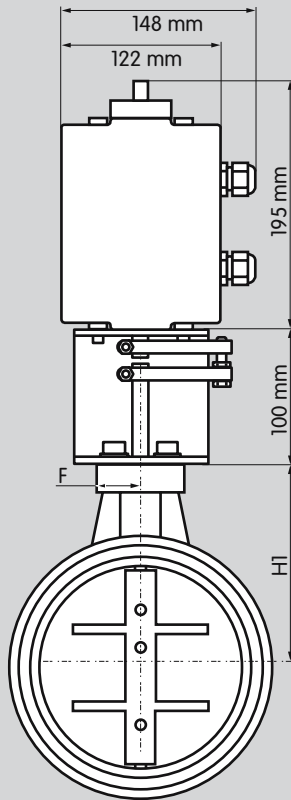

DKR nominal size	Dimensions	
	F	H1
DN 15, DN 20	35	60
DN 25	35	75
DN 32	35	80
DN 40	35	83
DN 50	35	85
DN 65	35	95
DN 80	35	105
DN 100	35	115
DN 125	35	135
DN 150	35	150
DN 200	35	175
DN 250	45	220
DN 300	45	240
DN 350	60	290
DN 400	60	335
DN 450	60	360
DN 500	60	400

6.2 Attachment set with linkage

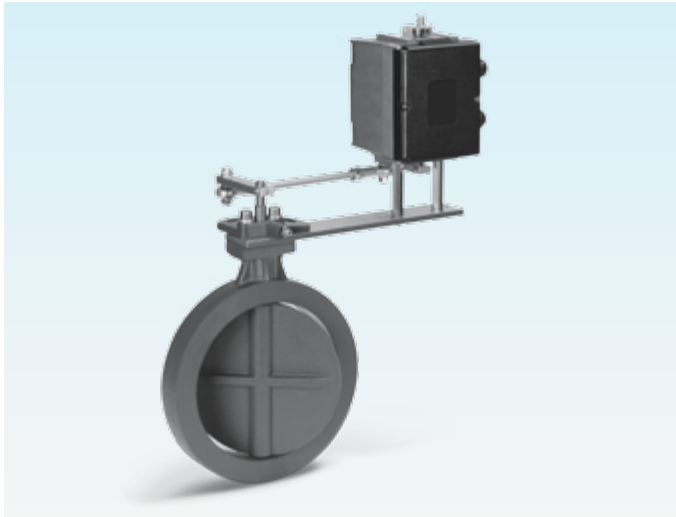

For butterfly valve DKR..D

With linkage, for fitting a gear motor GT 50 to a butterfly valve DKR..D. Fitted or enclosed as an additional item on delivery.

For nominal sizes	Order No.		Weight [kg]
	Enclosed	Fitted	
DN 15–20	26501300	26502000	1.5
DN 25–50	26501310	26502010	1.6
DN 65–100	26501320	26502020	1.7
DN 125	26501330	26502030	1.9
DN 150–200	26501340	26502040	1.9
DN 250	26501350	26502050	2.2
DN 300	26501360	26502060	2.2
DN 350	26501370	26502070	2.4
DN 400	26501380	26502080	2.5
DN 450–500	26501390	26502090	2.6

For butterfly valve DKR..A

With linkage and additional shock suppressor, for fitting a gear motor GT 50..U to a butterfly valve DKR..A. Fitted or enclosed as an additional item on delivery.

For nominal sizes	Order No.		Weight [kg]
	Enclosed	Fitted	
DN 15–20	26502350	26501400	1.6
DN 25–50	26502360	26501410	1.8
DN 65–100	26502370	26501420	1.9
DN 125	26502380	26501430	2.1
DN 150–200	26502390	26501440	2.1
DN 250	26502400	26501450	2.4
DN 300	26502410	26501460	2.4
DN 350	26502420	26501470	2.6
DN 400	26502430	26501480	2.7
DN 450–500	26502440	26501490	2.8

6.2.1 Dimensions

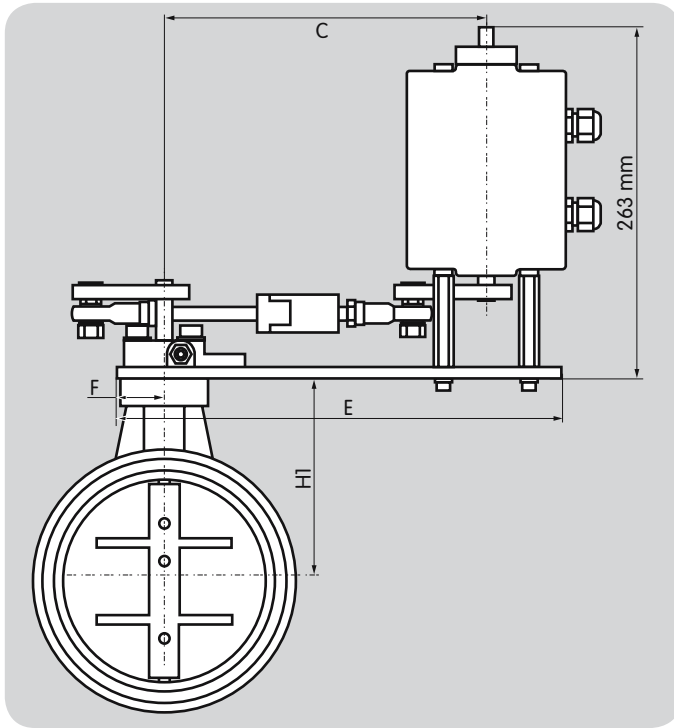

DKR nominal size	Dimensions [mm]			
	C	E	F	H1
DN 15, DN 20	194	285	35	60
DN 25	194	285	35	75
DN 32	194	285	35	80
DN 40	194	285	35	83
DN 50	194	285	35	85
DN 65	194	285	35	95
DN 80	194	285	35	105
DN 100	194	285	35	115
DN 125	239	330	35	135
DN 150	239	330	35	150
DN 200	239	330	35	175
DN 250	294	395	45	220
DN 300	294	395	45	240
DN 350	319	435	60	290
DN 400	350	465	60	335
DN 450	380	495	60	360
DN 500	380	495	60	400

6.3 Heat deflector

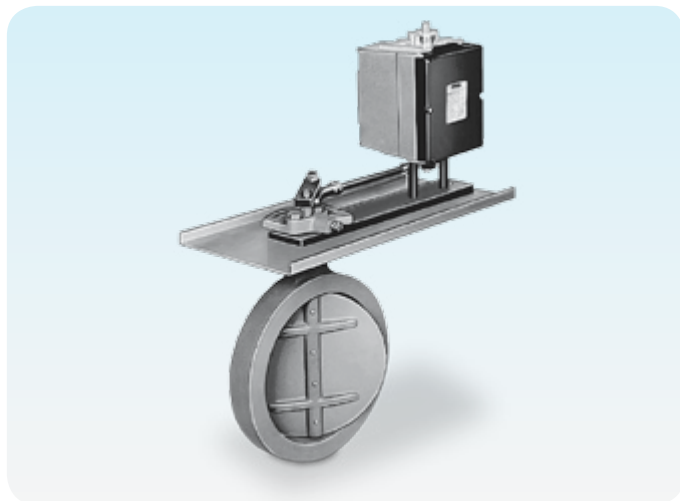

Heat deflector on DKR with attachment set and gear motor GT 50

Recommended for operation with hot air $\geq 250^{\circ}\text{C}$ in conjunction with the attachment set with linkage to protect the gear motor GT 50. The ambient temperature on the gear motor must not exceed 60°C .

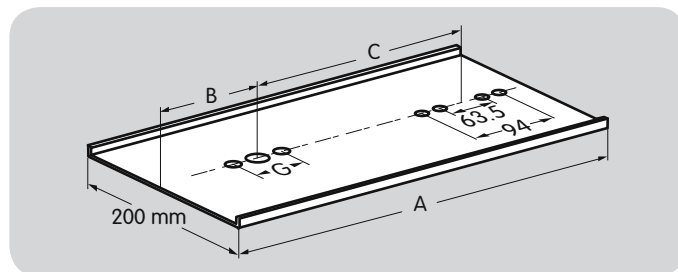

DKR nominal size	Dimensions [mm]				Order No.
	A	B	C	G	
DN 15–DN 20	366	70	194	36	5 650 450 0
DN 25–DN 50	366	70	194	36	5 650 451 0
DN 65–DN 100	366	70	194	36	5 650 452 0
DN 125	459	127	239	40	5 650 453 0
DN 150–DN 200	459	127	239	40	5 650 454 0
DN 250	566	180	294	60	5 650 455 0
DN 300	566	180	294	60	5 650 456 0
DN 350	619	207	319	80	5 650 457 0
DN 400	673	230	350	80	5 650 458 0
DN 450–DN 500	758	285	380	80	5 650 459 0

6.4 Attachment for foot assembly

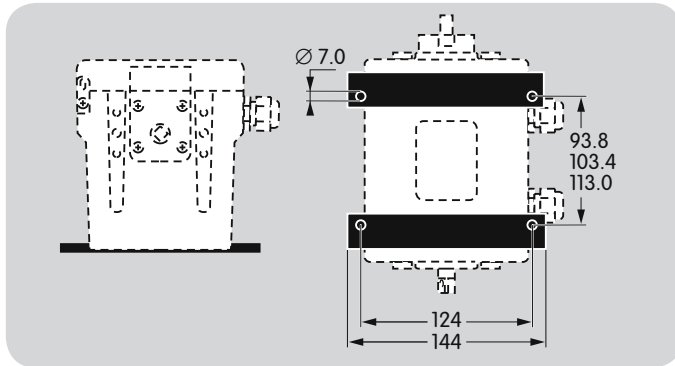

Comprising two rails to attach the actuator. By turning the individual rails, various drilling templates can be used (124 mm × 93.8 mm, 124 mm × 103.4 mm or 124 mm × 113.0 mm).

Attachment for foot assembly GT 50 /B (enclosed),
Order No. 2 630 105 0.

Attachment for foot assembly GT 50 /E (fitted),
Order No. 2 637 105 0.

6.5 Feedback potentiometer

The feedback potentiometer offers the option of monitoring the current position of the actuator.

The feedback potentiometer is installed at the factory. It cannot be retrofitted.

Capacity: max. 0.5 W.

Potentiometer	Order No.
RP 50/90 150 OHM /E	2 630 051 0
RP 50/90 250 OHM /E	2 630 052 0
RP 50/90 1000 OHM /E	2 630 055 0
RP 50/160 150 OHM /E	2 630 148 0
RP 50/160 250 OHM /E	2 630 149 0
RP 50/160 1000 OHM /E	2 630 152 0

Other values on request.

6.6 Current sensor

The current sensor offers the option of monitoring the current position of the actuator.

The current sensor is installed at the factory. It cannot be retrofitted.

Load impedance: max. 500 Ω.

RS50/90 4-20 mA /E (fitted), Order No. 2 630 158 0,

RS50/160 4-20 mA /E (fitted), Order No. 2630 159 0.

7 Technical data

Mains voltage:

220/240 V AC, -15/+10%, 50/60 Hz,

110/120 V AC, -15/+10%, 50/60 Hz,

24 V AC, -15/+10%, 50/60 Hz.

Power consumption, running time and torque:

Type	Power consumption [VA] at		Running time* for rotary movement [s]		Torque** [Nm]
	50 Hz	60 Hz	0–90°	0–160°	
GT 50-03	11	13.3	3.7	–	3.7
GT 50-07	11	13.3	7.5	–	7.5
GT 50-15	11	13.3	15	–	15
GT 50-30	11	13.3	30	–	20
GT 50-60	4.8	5.8	60	–	20
GT 50-120	4.8	5.8	120	–	20
GT 50-06	4.8	5.8	–	6.5	3.7
GT 50-13	4.8	5.8	–	13	7.5
GT 50-27	4.8	5.8	–	27	15
GT 50-54	4.8	5.8	–	54	20
GT 50-107	4.8	5.8	–	107	20
GT 50-214	4.8	5.8	–	214	20

* At 50 Hz. The running time drops to approx. 83% at 60 Hz.

** When driving two shafts, the torques of the individual shafts must be added together.

Screw terminals for cables up to 4 mm² (single core cables) and for cables up to 2.5 mm² with wire end ferrules.

Angle of rotation:

GT 50-03 to GT 50-120: 0–90°, adjustable,

GT 50-06 to GT 50-214: 0–160°, adjustable.

Holding torque = torque.

Electrical connection:

line entrance via 2 × PG 13.5 plastic cable glands.

Switching capacity of the position switches:

Voltage	Resistive load	Incandescent lamp load	Inductive load
125 V AC	2 A	0.5 A	2 A
250 V AC	2 A	0.5 A	2 A
< 30 V DC	2 A	2 A	2 A
< 50 V DC	1 A	0.4 A	1 A
< 75 V DC	0.75 A	0.3 A	0.75 A
< 125 V DC	0.5 A	0.2 A	0.03 A
< 250 V DC	0.25 A	0.1 A	0.03 A
12–30 V AC/DC	10–100 mA	–	10–100 mA

Enclosure: IP 54 pursuant to IEC 529.

Safety class: I pursuant to EN 60335.

Ambient and storage temperature: -20 to +60°C, no condensation permitted.

Weight: 2.6 kg.

Direction of rotation

Anti-clockwise from 0 to 90°.

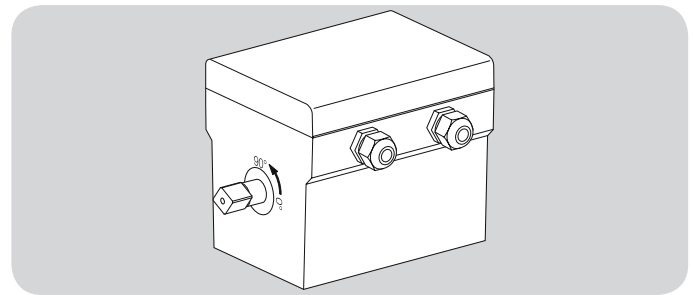

GT 50..E

Power consumption:

6.3 VA at 50 Hz, 7.3 VA at 60 Hz.

Feedback output:

max. 500 Ω load impedance.

Input:

4 (0)–20 mA: 50 Ω load impedance,

0–10 V: 150 k Ω input resistance.

7.1 Dimensions

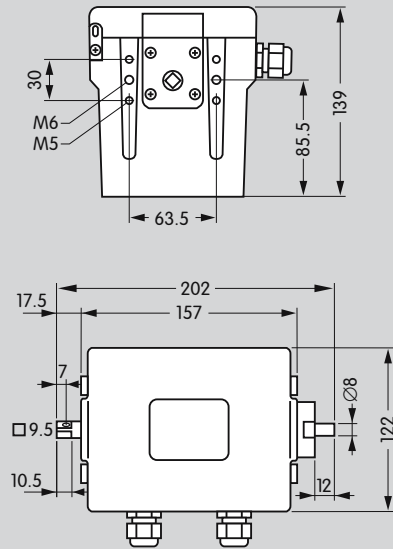

8 Maintenance cycles

Gear motor GT 50 suffers little wear and requires little servicing.

We recommend a function check once a year.

Feedback

Finally, we are offering you the opportunity to assess this "Technical Information (TI)" and to give us your opinion, so that we can improve our documents further and suit them to your needs.

Clarity

Found information quickly
Searched for a long time
Didn't find information
What is missing?
No answer

Comprehension

Coherent
Too complicated
No answer

Scope

Too little
Sufficient
Too wide
No answer

inter
active

Use

To get to know the product
To choose a product
Planning
To look for information

Navigation

I can find my way around
I got "lost"
No answer

My scope of functions

Technical department
Sales
No answer

Remarks

(Adobe Reader 7 or higher required)
www.adobe.com



elster
Kromschroeder

Contact

Elster GmbH
Postfach 2809 · 49018 Osnabrück
Strothweg 1 · 49504 Lotte (Büren)
Germany

T +49 541 1214-0
F +49 541 1214-370
info@kromschroeder.com
www.kromschroeder.com

The current addresses of our international agents are available on the Internet:

www.kromschroeder.de/index.php?id=718&L=1

We reserve the right to make technical modifications in the interests of progress.

Copyright © 2014 Elster GmbH
All rights reserved.