

## Impulse system MPT 700

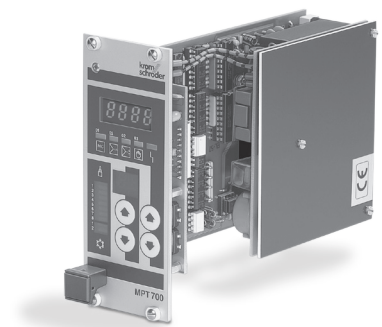

<b>1</b>	<b>Introduction .....</b>	<b>4</b>
1.1	Version and model.....	5
1.2	CE Mark.....	7
<b>2</b>	<b>Operation .....</b>	<b>8</b>
2.1	Controls .....	8
2.1.1	Front panel.....	8
2.1.2	Parameter display.....	9
2.1.3	Group indicator .....	9
2.1.4	Setting source indicators.....	9
2.1.5	Malfunction indicator.....	10
2.1.6	Switching output indicators .....	10
2.1.7	Keypad.....	10
2.2	Operation of the unit .....	11
2.2.1	General.....	11
2.2.2	Parameters 0...4: normal operation .....	11
2.2.3	Parameter entry - general.....	11
<b>3</b>	<b>Modes of operation .....</b>	<b>13</b>
3.1	Mode of operation 1 - heating with fixed pulse width .....	13
3.2	Mode of operation 2 - heating/cooling with fixed pulse width.....	14
3.3	Mode of operation 3 - heating with variable pulse width and spacing.....	16
3.4	Mode of operation 4 - heating/cooling with variable pulse width and spacing .	18
3.5	Mode of operation 5 - heating with fixed pulse width and separate air and gas valve control.....	21
3.6	Mode of operation 6 - heating/cooling with fixed pulse width and separate air and gas valve control.....	23
3.7	Mode of Operation 7- heating with variable pulse width and spacing and separate air and gas valve control .....	25
3.8	Mode of Operation 8 - heating/cooling with variable pulse width and spacing and separate air and gas valve control .....	28
<b>4</b>	<b>Adjustable parameters 10...87 .....</b>	<b>31</b>
4.1	Parameter 10 - setting source .....	31
4.2	Parameter 11 - mode of operation.....	32
4.3	Parameter 12, 13 - equipment address .....	32
4.4	Parameter 14 - setting indicator.....	32
4.5	Parameters 15, 16 - number of outputs .....	32
4.6	Parameter 18 - MPT mode .....	33
4.7	Parameter 19 - keyboard repetition rate .....	33
4.8	Parameters 20...27 - ignition timing, channels 1...8.....	33
4.9	Parameter 28, 29 - setting control factor .....	35
4.10	Parameter 30, 31 - heating/cooling limit .....	35
4.11	Parameter 32, 33 - heating/cooling dead zone .....	35
4.12	Parameter 34, 35 - continuous pulse.....	37
4.13	Parameter 36, 37 - control rate (three-point step controller) .....	37
4.14	Parameter 38, 39 - fixed setting.....	38
4.15	Parameters 40...47 / 60...67 - pulse widths .....	38
4.16	Parameters 48, 54, 68, 74 - minimum on time.....	39
4.17	Parameters 49, 55, 69, 75 - minimum off time.....	39

---

4.18	Parameters 50...53 / 56...59 / 70...73 / 76...79 - delays .....	39
4.19	Parameter 87 - equipment code.....	40
<b>5</b>	<b>Appendix .....</b>	<b>41</b>
5.1	Installation.....	41
5.1.1	Proper use.....	41
5.1.2	Installation notes and safety precautions .....	41
5.1.3	General .....	42
5.1.4	Ground connection.....	43
5.1.5	Power supply connections.....	43
5.1.6	Binary control inputs.....	44
5.1.7	mA control inputs .....	44
5.1.8	Switching outputs .....	45
5.2	Connection Plans .....	46
5.2.1	Main board .....	46
5.2.2	Power supply board .....	47
5.2.3	Jumpers (on main board).....	48
5.2.4	Fuses (on power supply board).....	48
5.2.5	Block diagram (overview) .....	49
5.2.6	Terminal plan (CN1).....	50
5.3	Brief instructions.....	51
5.3.1	Modes of operation .....	51
5.3.2	Parameter 10 - setting source .....	51
5.3.3	Parameters 0...99.....	52
5.4	Test and service instructions.....	53
5.4.1	Parameter 5: test mA control input/phase.....	54
5.4.2	Parameter 6: test of binary control inputs .....	54
5.4.3	Parameter 7: test of switching outputs .....	55
5.4.4	Parameter 8: error parameter number .....	55
5.4.5	Parameter 9: error code .....	56
5.4.6	Parameters 90...98: event counters .....	57
5.4.7	Parameter 99: display test .....	57
5.4.8	Cold start.....	57
5.4.9	Connections .....	57
5.5	Technical specifications .....	58

# 1 Introduction

## ***Dear Customer,***

Thank you very much for the interest which you have shown in our products.

You have opted for our new generation of equipment in accordance with CE requirements, the *MPT 700 Rev.C burner cycle control unit*, which is designed for controlling up to eight burners in one or two groups in any of eight modes of operation.

This unit was developed on the basis of our experience with the preceding model, the MPT 608/618, and the wishes of our customers.

The unit incorporates the following improvements:

- 1...8 burner outputs, irrespective of the hardware configuration
- separate connections for 3-point step control, mA control, heating/cooling and malfunction signals ⇒ no jumper settings required
- power supply unit designed for 95...240VAC input and low heat emission
- safety-oriented logic for heating/cooling and malfunction outputs (heating/no malfunction ⇒ output active)
- switching outputs positive (+12...24VDC) and common ground
- two mA inputs ⇒ no external pulse relay required
- checking the measured values of the analog input channels on accuracy (mA-Input)

Please read this manual, especially the installation and commissioning instructions (section 5.1), carefully and follow the instructions. Otherwise, we will be unable to assume any warranty for damage to the unit.

If you have any further questions, please do not hesitate to contact your supplier, who will be pleased to help you.

G. Kromschröder AG  
Strothweg 1  
D-49504 Lotte (Büren)  
Germany

Tel.: +49/0-541-1214-0  
Fax.: +49/0-541-1214-370

## 1.1 Version and model

- MPT 700 with *two burner groups* per unit:
  - current version: Type 2 / program version 6.1
  - 8 modes of operation
  - two parameter sets, switchable
  - two mA inputs
  - one three-point step input for multiplex operation

The MPT 700 can be adjusted to behave in the same way as a single-group unit by setting the number of outputs for group 1 to 8 burners (parameter 15) and for group 2 to 0 burners (parameter 16) and the setting indicator to group 1 (parameter 14).

To check the version, proceed as follows (see also section 2):

- Set the parameter number to 0 using the right section of the keypad.
- Press the top button on the right (+) for 5 sec.

⇒ the type and the program version number will then appear on the display.

Example:

display: 02.61 ⇒ Type 2 / program version 6.1

MPT 700:

- **new model with switched +Vcc (+12...24VDC) and common ground (GND)**

For downward compatibility reasons, it is still possible to operate the MPT 700 in the 608 software mode (see section 4.6)

For intention to replace the MPT 608 as well as the MPT 618 with the MPT 700, it's necessary to make some changes in the wiring of the installation:

- Wiring of the electrical connections to a different mating plug
- In mode 108 / 128 it's necessary to link a grounding conductor as like shown in the terminal plan (see Section 5.2.6). In mode 108 the burner output 8 is used for 'Heating / Cooling' with the Single Group Unit and burner output 7 and 8 with the Dual Group Unit.

take into consideration that the switching logic for the outputs 'Heating Cooling 1', 'Heating Cooling 2' and 'Out /Error' in the ESV 128 is different to the ESV 148. Therefore the connected relays may have another switching reaction.

The differences are shown in the following table:

Type	Out H/K 1	Out H/K 2	Out /Error
MPT 608	switched	switched	switched
MPT 700	not switched	not switched	not switched

Normally for the same function other switching contacts must be used. (the contacts has to be changed instead of a normally closed contact to a normally open contact and the other way round dependent of plant specific facts)

- Basically the instructions of installation in the appendix (section 5) for the MPT 700 device must be used.

Before commissioning the unit, always check the model (nameplate), the version (follow the instructions above) and the parameters set. Otherwise, the unit or the equipment connected may be damaged or destroyed.

## 1.2 CE Mark

CE marks are applied in accordance with a Directive of the Council of the European Communities of 29 April 1991 on the approximation of the laws of the Member States relating to the mutual recognition of conformity. Since the 01 Januar 1997 all temporary regulations had been dropped, so the new "EG concurring standartisations" are valid.

The MPT 700 burner cycle control unit described in this manual is supplied complete with a CE mark guaranteeing:

- compliance with the electromagnetic compatibility directive
- compliance with the low-voltage directive

## 2 Operation

### 2.1 Controls

#### 2.1.1 Front panel

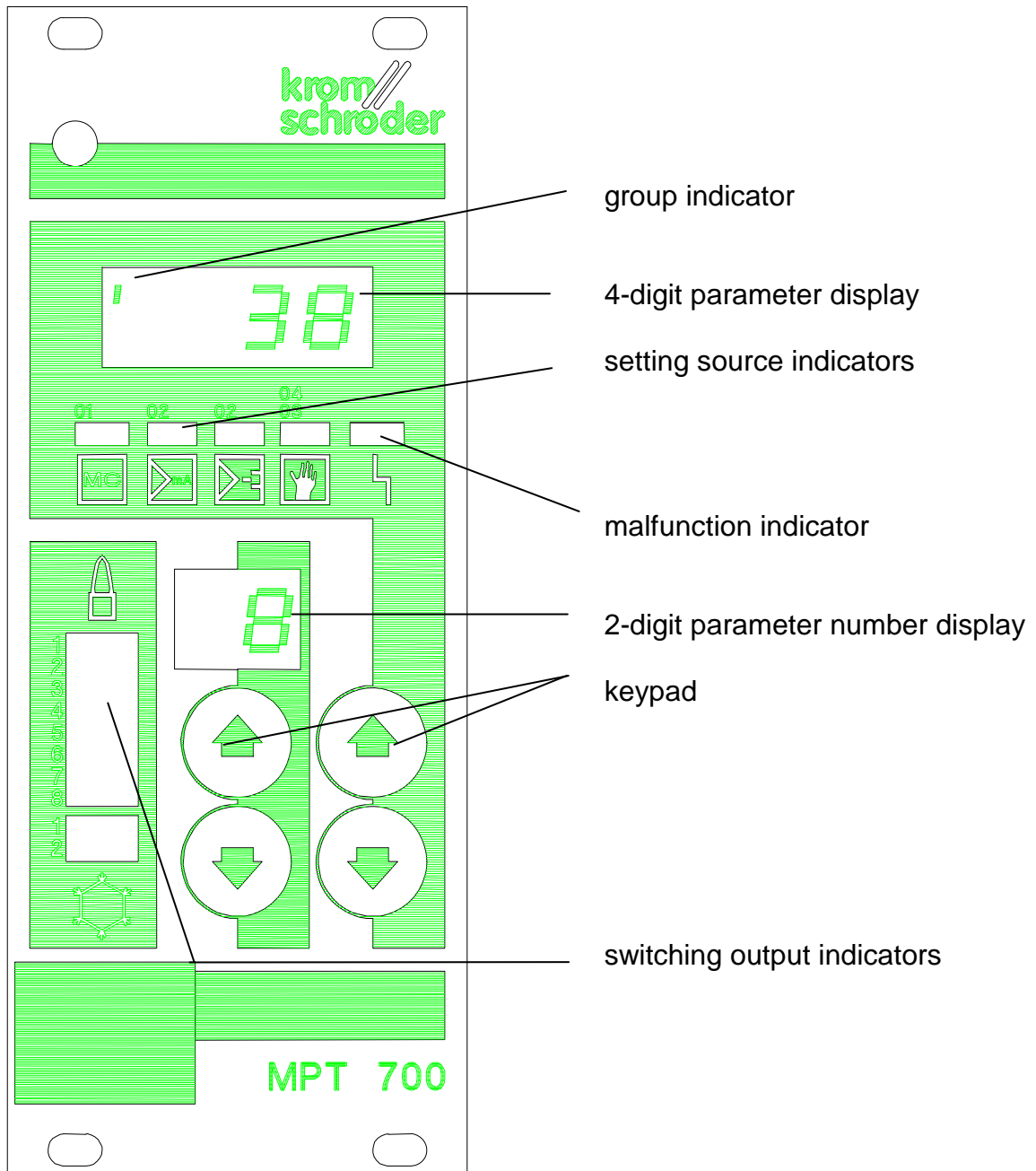



### 2.1.2 Parameter display

- In operation, the parameter display indicates the current setting.

heating           ⇒     0%...+100%  
 heating/cooling ⇒   -100%...+100%

- During parameter input, the value of the parameter is indicated in the unit which is valid at the time.
- Error codes and service parameters are only indicated for troubleshooting and inspection purposes.

### 2.1.3 Group indicator

- During normal operation, this indicator indicates the group to which the setting which is displayed applies.

1 bar           ⇒     group 1  
 2 bars         ⇒     group 2

### 2.1.4 Setting source indicators

- These indicators show the setting source which is currently active.

MC           ⇒     MPT 700: no function

mA           ⇒     control by analogue 0/4...20mA signal

 ⇒     three-point step controller

 ⇒     manual control

- If a green LED flashes, no valid setting is available at the input concerned (this only applies to 'MC' and 'mA' (0/4...20mA)).

MC           ⇒     MPT 700: no function

mA           ⇒     mA value < 2mA or > 20,7mA (in 4...20mA operation)  
 mA value > 20,7 mA (in 0...20mA operation)

### 2.1.5 Malfunction indicator

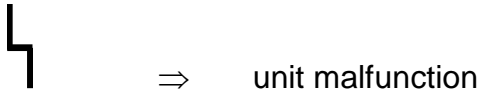

- If the unit detects a malfunction during its cyclical self-test, the red LED is lit, the 4 green LEDs all flash and the binary "malfunction" output signal is activated. Troubleshooting is described in section 5.4 below.  
In case of the fault 'mA' is happened (source indicator 02), the green LED is lit and the "malfunction" indicator is gone into steady light. Simultaneous the output "malfunction" (Out /Error) is set.

### 2.1.6 Switching output indicators

- These LEDs indicate which outputs are being addressed at any time.
- As the indicators only indicate that the output drivers are being addressed, it is not possible to use them for detecting a faulty output driver or a wire breakage.

### 2.1.7 Keypad

- left buttons:

selection of setting source  
selection of parameters  
selection of service displays

- right buttons:

changing the setting in manual operation  
changing parameter values

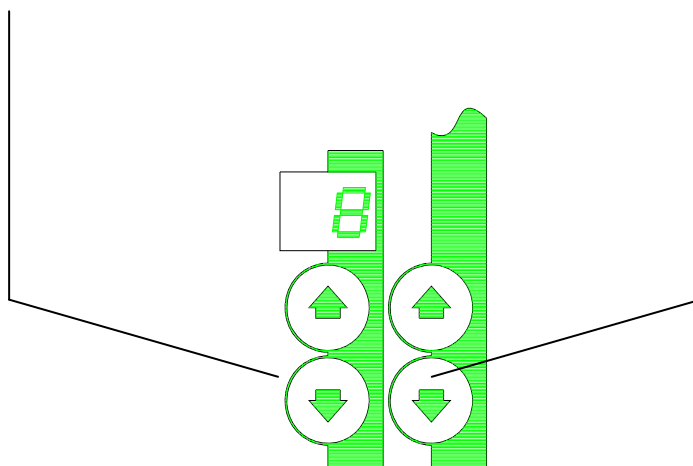

All the functions of the unit, including setting input, parameter entry and troubleshooting, must be implemented manually.

## 2.2 Operation of the unit

### 2.2.1 General

All the functions of the unit, including parameter changes, the selection of a setting source/calling up the setting and troubleshooting, can be initiated manually using the keypad.

### 2.2.2 Parameters 0...4: normal operation

- For NORMAL OPERATION, the parameter number display must be set to a value between 0 and 4.
- Changes in the signal source (e.g. 2  $\Rightarrow$  3) are only implemented after about 5 sec. This delay prevents uncontrolled changes in parameter selection.

Parameter No.	Meaning
0	all outputs are reset
1	MPT 700: no function
2	setting from controller (continuous / three-point step)
3	manual setting for group 1
4	manual setting for group 2

### 2.2.3 Parameter entry - general

- In modes of operation 1 to 8, two parameter sets are available for pulse widths, min. on time, min. off time and ignition timing delays.
- The unit is switched over between parameter sets externally by binary input 2.

input 2 inactive  $\Rightarrow$  parameter set 1 valid

input 2 active  $\Rightarrow$  parameter set 2 valid

parameter set 1: parameters 40...59

parameter set 2: parameters 60...79

### **2.2.3.1 Selection of parameters**

- All the parameters can be checked while the unit is in service without any effect on operation.
- To check a parameter, select the parameter required using the left half of the keypad.  
  
⇒ The value of the parameter will then appear on the four-digit display in the valid unit.

### **2.2.3.2 Changing parameters**

- It is only possible to change parameters if the current equipment code is 0 or the correct equipment code is entered (see parameter 87).
- Select the parameter which you wish to change using the keypad.
- The current value of the parameter will then appear on the four-digit display.
- You can increase or reduce the value using the right half of the keypad.
- If you select another parameter, the value which you have entered will be stored in interim memory, but will not yet be effective.
- Changed parameters only become effective when the unit is switched back to NORMAL OPERATION (parameters 0 to 4).

### 3 Modes of operation

#### 3.1 Mode of operation 1 - heating with fixed pulse width

- The pulse width is set to a fixed value for each channel.
- If the setting is changed, the pulse spacing is changed.
- Max. pulse frequency =  $1 / (\text{pulse width} + \text{minimum off time})$
- Even before the unit changes from pulse operation to a continuous pulse, the minimum off time never falls below the set parameter value.

#### Adjustable parameters in mode of operation 1:

Parameter (G1/G2)	Designation	Range	Section	Remarks
10	setting source	0...5	4.1	
11	mode of operation	1	4.2	
12/13	equipment address	1...32	4.3	not relevant for operation
14	setting indicator	0...2	4.4	
15/16	number of outputs	0...8	4.5	
18	MPT mode	108/128	4.6	
19	keyboard repetition rate	1...32	4.7	
20...27	ZZP1...ZZP8	0/1...255	0	
34/35	continuous pulse	0/50...100%	4.12	0% ⇔ no continuous pulse
36/37	control rate	1...180s	4.13	only for TPS unit
38/39	fixed setting	0/1...100%	4.14	0% ⇔ no fixed setting
40...47	pulse widths	50ms...160s	4.15	parameter set 1
49/55	min. off time	50ms...160s	4.17	parameter set 1
60...67	pulse widths	50ms...160s	4.15	parameter set 2
69/75	min. off time	50ms...160s	4.17	parameter set 2
87	equipment code	0/1...255	4.19	0 ⇔ no equipment code

ZZP: ignition timing

TPS: three-point step controller

### 3.2 Mode of operation 2 - heating/cooling with fixed pulse width

- The pulse width is set to a fixed value for each channel.
- If the setting is changed, the pulse spacing is changed.
- Max. pulse frequency =  $1 / (\text{pulse width} + \text{minimum off time})$
- Even before the unit changes from pulse operation to a continuous pulse, the minimum off time never falls below the set parameter value.
- Setting source: heating/cooling limit and heating/cooling dead zone adjustable (see diagram in section 4.11)
- For burner and valve control a maximum of 8 outputs is available in 128 mode (a maximum of 6 in 108 mode).
- If required, a relay for external switchover between heating and cooling can be controlled by the heating/cooling 1 and 2 outputs (mode 128) or outputs 7 and 8 (mode 108).

⇒ output inactive:      cooling  
output active:        heating

Adjustable parameters in mode of operation 2:

Parameter (G1/G2)	Designation	Range	Section	Remarks
10	setting source	0...5	4.1	
11	mode of operation	2	4.2	
12/13	equipment address	1...32	4.3	not relevant for operation
14	setting indicator	0...2	4.4	
15/16	number of outputs	0...8	4.5	
18	MPT mode	108/128	4.6	
19	keyboard repetition rate	1...32	4.7	
20...27	ZZP1...ZZP8	0/1...255	0	
30/31	heating/cooling limit	10...90%	0	
32/33	heating/cooling dead zone	0...50%	4.11	
34/35	continuous pulse	0/50...100%	4.12	0% ⇔ no continuous pulse
36/37	control rate	1...180s	4.13	only for TPS unit
38/39	fixed setting	0/1...100%	4.14	0% ⇔ no fixed setting
40...47	pulse widths	50ms...160s	4.15	parameter set 1
49/55	min. off time	50ms...160s	4.17	parameter set 1
60...67	pulse widths	50ms...160s	4.15	parameter set 2
69/75	min. off time	50ms...160s	4.17	parameter set 2
87	equipment code	0/1...255	4.19	0 ⇔ no equipment code

ZZP: ignition timing

TPS: three-point step controller

### 3.3 Mode of operation 3 - heating with variable pulse width and spacing

- In this mode of operation, no fixed pulse widths are defined.
- The pulse width or the pulse spacing changes as a function of the setting.
- Max. pulse frequency =  $1 / (\text{min. on time} + \text{min. off time})$
- The maximum pulse frequency is reached at a setting corresponding to the value entered for parameter 28 and 29 ('XX' in diagram).
- Even before the unit changes from pulse operation to a continuous pulse, the minimum off time never falls below the set parameter value.

#### Pulse diagram:

1. setting 1%

⇒ min. on time / max. off time



2. setting 1%...XX%

⇒ min. on time / off time is reduced



3. setting XX%

⇒ min. on time / min. off time  
maximum pulse frequency



4. setting XX%...99%

⇒ min. off time / on time is increased

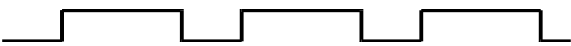

5. setting 100%

⇒ continuous pulse

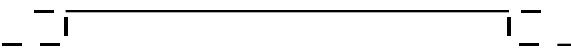

XX% ⇒ value in parameter 28 (10...90%)



**Adjustable parameters in mode of operation 3:**

Parameter (G1/G2)	Designation	Range	Section	Remarks
10	setting source	0...5	4.1	
11	mode of operation	3	4.2	
12/13	equipment address	1...32	4.3	not relevant for operation
14	setting indicator	0...2	4.4	
15/16	number of outputs	0...8	4.5	
18	MPT mode	108/128	4.6	
19	keyboard repetition rate	1...32	4.7	
20...27	ZZP1...ZZP8	0/1...255	0	
28/29	setting control factor	10...90%	4.9	
34/35	continuous pulse	0/50...100%	4.12	0% ⇔ no continuous pulse
36/37	control rate	1...180s	4.13	only for TPS unit
38/39	fixed setting	0/1...100%	4.14	0% ⇔ no fixed setting
48/54	min. on time	50ms...160s	4.15	parameter set 1
49/55	min. off time	50ms...160s	4.17	parameter set 1
68/74	min. on time	50ms...160s	4.15	parameter set 2
69/75	min. off time	50ms...160s	4.17	parameter set 2
87	equipment code	0/1...255	4.19	0 ⇔ no equipment code

ZZP: ignition timing

TPS: three-point step controller

### 3.4 Mode of operation 4 - heating/cooling with variable pulse width and spacing

- In this mode of operation, no fixed pulse widths are defined.
- The pulse width or the pulse spacing changes as a function of the setting.
- Max. pulse frequency =  $1 / (\text{min. on time} + \text{min. off time})$
- The maximum pulse frequency is reached at a setting corresponding to the value entered for parameter 28 and 29 ('XX' in diagram).
- Even before the unit changes from pulse operation to a continuous pulse, the minimum off time never falls below the set parameter value.
- Setting source: heating/cooling limit and heating/cooling dead zone adjustable (see diagram in section 4.11)
- For burner and valve control a maximum of 8 outputs are available in 128 mode (a maximum of 6 in 108 mode).
- If required, a relay for external switchover between heating and cooling can be controlled by the heating/cooling 1 and 2 outputs (mode 128) or outputs 7 and 8 (mode 108).

⇒ output inactive:      cooling  
output active:        heating

**Pulse diagram:**

1. setting 1%

⇒ min. on time / max. off time

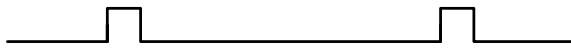

2. setting 1%...XX%

⇒ min. on time / off time is reduced



3. setting XX%

⇒ min. on time / min. off time  
maximum pulse frequency



4. setting XX%...99%

⇒ min. off time / on time is increased

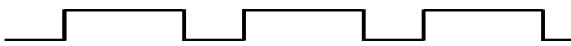

5. setting 100%

⇒ continuous pulse

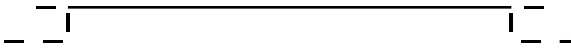

XX% ⇒ value in parameter 28 (10...90%)

**Adjustable parameters in mode of operation 4:**

Parameter (G1/G2)	Designation	Range	Section	Remarks
10	setting source	0...5	4.1	
11	mode of operation	4	4.2	
12/13	equipment address	1...32	4.3	not relevant for operation
14	setting indicator	0...2	4.4	
15/16	Number of outputs	0...8	4.5	
18	MPT mode	108/128	4.6	
19	keyboard repetition rate	1...32	4.7	
20...27	ZZP1...ZZP8	0/1...255	0	
28/29	setting control factor	10...90%	4.9	
30/31	heating/cooling limit	10...90%	0	
32/33	heating/cooling dead zone	0...50%	4.11	
34/35	continuous pulse	0/50...100%	4.12	0% ⇔ no continuous pulse
36/37	control rate	1...180s	4.13	only for TPS control
38/39	fixed setting	0/1...100%	4.14	optional 0% ⇔ no fixed setting
48/54	min. on time	50ms...160s	4.16	parameter set 1
49/55	min. off time	50ms...160s	4.17	parameter set 1
68/74	min. on time	50ms...160s	4.16	parameter set 2
69/75	min. off time	50ms...160s	4.17	parameter set 2
87	equipment code	0/1...255	4.19	0 ⇔ no equipment code

ZZP: ignition timing

TPS: three-point step controller

### 3.5 Mode of operation 5 - heating with fixed pulse width and separate air and gas valve control

- The pulse width is set to a fixed value for each channel. ( air- and gas valve )  
The pulse widths for the air valves can be set in parameter 40,42,44,46 and for the gas valves in parameter 41,43,45,47.
- If the setting is changed, the pulse spacing is changed.
- Max. pulse frequency =  $1 / (\text{max. pulse width} + \text{minimum off time})$
- Even before the unit changes from pulse operation to a continuous pulse, the minimum off time never falls below the set parameter value.
- Outputs 1-3-5-7 control the air valves.
- Outputs 2-4-6-8 control the corresponding gas valves.
- The ignition timing for outputs 1-3-5-7 must be set.
- Outputs 2-4-6-8 are activated with the set delay following outputs 1-3-5-7.
- Any ignition timing entered for outputs 2-4-6-8 is not effective.

$\text{delay} \leq \text{pulse width for air valves (1-3-5-7)} + \text{min. off time}$

ZZP: ignition timing

#### Pulse diagram:

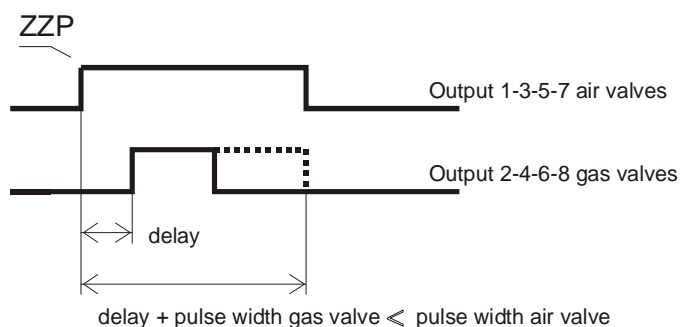

**Adjustable parameters in mode of operation 5:**

Parameter (G1/G2)	Designation	Range	Section	Remarks
10	setting source	0...5	4.1	
11	mode of operation	5	4.2	
12/13	equipment address	1...32	4.3	not relevant for operation
14	setting indicator	0...2	4.4	
15/16	number of outputs	0...8	4.5	
18	MPTde	108/128	4.6	
19	keyboard repetition rate	1...32	4.7	
20,22,24,26	ZZP1, 3, 5, 7	0/1...255	0	outputs 1, 3, 5, 7
34/35	continuous pulse	0/50...100%	4.12	0% ⇔ no continuous pulse
36/37	control rate	1...180s	4.13	only for TPS unit
38/39	fixed setting	0/1...100%	4.14	optional 0% ⇔ no fixed setting
40...47	pulse widths	50ms...160s	4.15	parameter set 1
49/55	min. off time	50ms...160s	4.17	parameter set 1
50-53/56-59	delay	10ms...20s	4.18	parameter set 1
60...67	pulse widths	50ms...160s	4.15	parameter set 2
69/75	min. off time	50ms...160s	4.17	parameter set 2
70-73/76-79	delay	10ms...20s	4.18	parameter set 2
87	equipment code	0/1...255	4.19	0 ⇔ no equipment code

ZZP: ignition timing

TPS: three-point step controller

### 3.6 Mode of operation 6 - heating/cooling with fixed pulse width and separate air and gas valve control

- The pulse width is set to a fixed value for each channel. ( air- and gas valve )  
The pulse widths for the air valves can be set in parameter 40,42,44,46 and for the gas valves in parameter 41,43,45,47.
- If the setting is changed, the pulse spacing is changed.
- Max. pulse frequency =  $1 / (\text{pulse width} + \text{minimum off time})$
- Even before the unit changes from pulse operation to a continuous pulse, the minimum off time never falls below the set parameter value.
- Setting source: heating/cooling limit and heating/cooling dead zone adjustable (see diagram in section 4.11)
- Outputs 1-3-5-7 control the air valves.
- Outputs 2-4-6-8 control the corresponding gas valves.
- The ignition timing for outputs 1-3-5-7 must be set.
- Outputs 2-4-6-8 are activated with the set delay following outputs 1-3-5-7.
- Any ignition timing entered for outputs 2-4-6-8 is not effective.
- In cooling operation, only outputs 1-3-5-7 (air valves) are active.
- In 128 mode, the output heating/cooling 1 and heating/cooling 2 is also used for heating/cooling.

⇒ output inactive: cooling      output active: heating

delay  $\leq$  pulse width for air valves (1-3-5-7) + min. off time

ZZP: ignition timing

#### Pulse diagram:

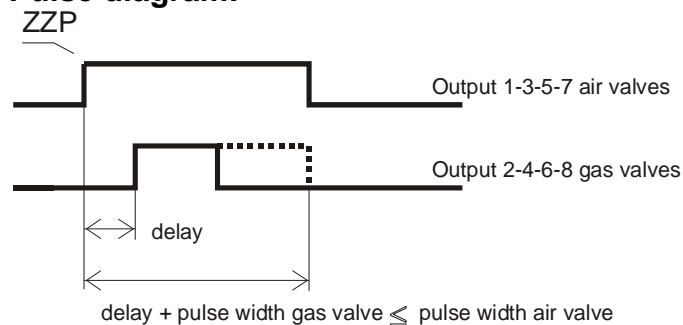

**Adjustable parameters in mode of operation 6:**

Parameter (G1/G2)	Designation	Range	Section	Remarks
10	setting source	0...5	4.1	
11	mode of operation	6	4.2	
12/13	equipment address	1...32	4.3	not relevant for operation
14	setting indicator	0...2	4.4	
15/16	number of outputs	0...8	4.5	
18	MPT mode	108/128	4.6	
19	keyboard repetition rate	1...32	4.7	
20,22,24,26	ZZP1, 3, 5, 7	0/1...255	0	outputs 1, 3, 5, 7
30/31	heating/cooling limit	10...90%	0	
32/33	heating/cooling dead zone	0...50%	4.11	
34/35	continuous pulse	0/50...100%	4.12	0% ⇔ no continuous pulse
36/37	control rate	1...180s	4.13	only for TPS control
38/39	fixed setting	0/1...100%	4.14	optional 0% ⇔ no fixed setting
40...47	pulse widths	50ms...160s	4.15	parameter set 1
49/55	min. off time	50ms...160s	4.17	parameter set 1
50-53/56-59	delay	10ms...20s	4.18	parameter set 1
60...67	pulse widths	50ms...160s	4.15	parameter set 2
69/75	min. off time	50ms...160s	4.17	parameter set 2
70-73/76-79	delay	10ms...20s	4.18	parameter set 2
87	equipment code	0/1...255	4.19	0 ⇔ no equipment code

ZZP: ignition timing

TPS: three-point step controller



### 3.7 Mode of Operation 7- heating with variable pulse width and spacing and separate air and gas valve control

- In this mode of operation, no fixed pulse widths are defined.
- The pulse width or the pulse spacing changes as a function of the setting.
- Max. pulse frequency =  $1 / (\text{min. on time} + \text{min. off time})$
- The maximum pulse frequency is reached at a setting corresponding to the value entered for parameter 28 and 29 ('XX' in diagram).
- Even before the unit changes from pulse operation to a continuous pulse, the minimum off time never falls below the set parameter value.
- Outputs 1-3-5-7 control the air valves.
- Outputs 2-4-6-8 control the corresponding gas valves.
- The ignition timing for outputs 1-3-5-7 must be set.
- Outputs 2-4-6-8 are activated with the set delay following outputs 1-3-5-7.
- Any ignition timing entered for outputs 2-4-6-8 is not effective.

$$\text{delay} \leq \text{min. on time} + \text{min. off time}$$

ZZP: ignition timing

**Pulse diagram:**

**1. setting 1%**

⇒ min. on time / max. off time

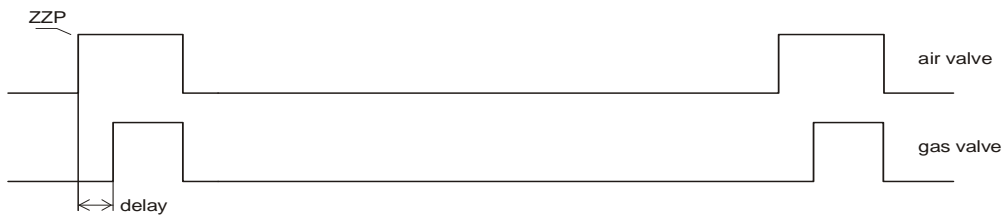

**2. setting 1%...XX%**

⇒ min. on time / off time is reduced

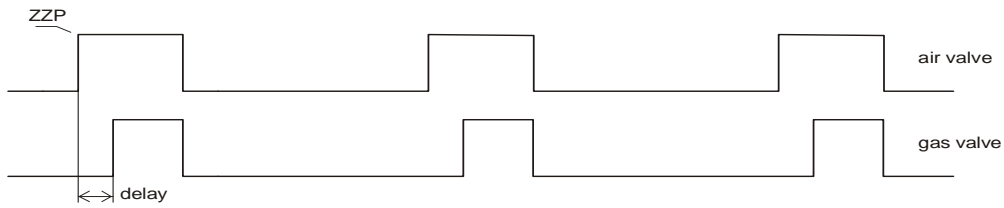

**3. setting XX%**

⇒ min. on time / min. off time  
maximum pulse frequency

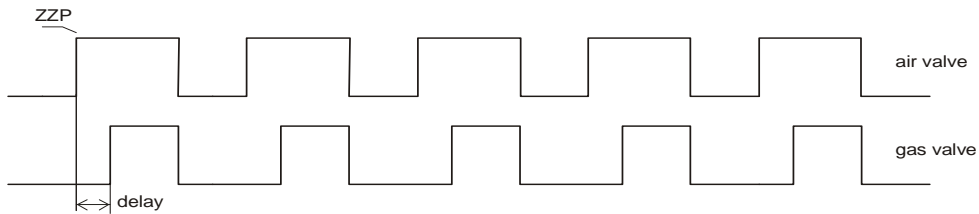

**4. setting XX%...99%**

⇒ min. off time / on time is increased

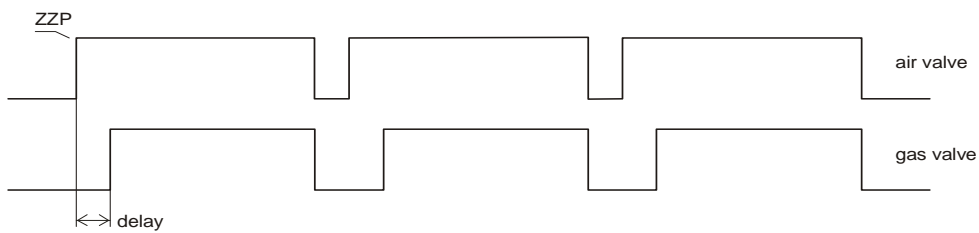

**5. setting 100%**

⇒ continuous pulse

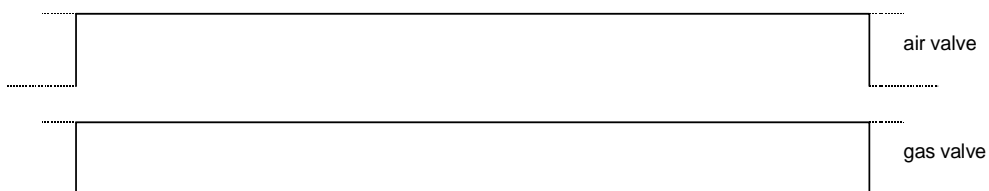

XX% ⇒ value in parameter 28 (10...90%)

**Adjustable parameters in mode of operation 7:**

Parameter (G1/G2)	Designation	Range	Section	Remarks
10	setting source	0...5	4.1	
11	mode of operation	7	4.2	
12/13	equipment address	1...32	4.3	not relevant for operation
14	setting indicator	0...2	4.4	
15/16	number of outputs	0...8	4.5	
18	MPT mode	108/128	4.6	
19	keyboard repetition rate	1...32	4.7	
20,22,24,26	ZZP1, 3, 5, 7	0/1...255	0	outputs 1, 3, 5, 7
28/29	setting control factor	10...90%	4.9	
34/35	continuous pulse	0/50...100%	4.12	0% ⇔ no continuous pulse
36/37	control rate	1...180s	4.13	only for TPS unit
38/39	fixed setting	0/1...100%	4.14	optional 0% ⇔ no fixed setting
48/54	min. on time	50ms...160s	4.15	parameter set 1
49/55	min. off time	50ms...160s	4.17	parameter set 1
50-53/56-59	delay	10ms...20s	4.18	parameter set 1
68/74	min. on time	50ms...160s	4.15	parameter set 2
69/75	min. off time	50ms...160s	4.17	parameter set 2
70-73/76-79	delay	10ms...20s	4.18	parameter set 2
87	equipment code	0/1...255	4.19	0 ⇔ no equipment code

ZZP: ignition timing

TPS: three-point step controller

### 3.8 Mode of Operation 8 - heating/cooling with variable pulse width and spacing and separate air and gas valve control

- In this mode of operation, no fixed pulse widths are defined.
- The pulse width or the pulse spacing changes as a function of the setting.
- Max. pulse frequency =  $1 / (\text{min. on time} + \text{min. off time})$
- The maximum pulse frequency is reached at a setting corresponding to the value entered for parameter 28 and 29 ('XX' in diagram).
- Even before the unit changes from pulse operation to a continuous pulse, the minimum off time never falls below the set parameter value.
- Setting source: heating/cooling limit and heating/cooling dead zone adjustable (see diagram in section 4.11)
- Outputs 1-3-5-7 control the air valves.
- Outputs 2-4-6-8 control the corresponding gas valves.
- The ignition timing for outputs 1-3-5-7 must be set.
- Outputs 2-4-6-8 are activated with the set delay following outputs 1-3-5-7.
- Any ignition timing entered for outputs 2-4-6-8 is not effective.
- In cooling operation, only outputs 1-3-5-7 (air valves) are active.
- In 128 mode, the output heating/cooling 1 and heating/cooling 2 is also used for heating/cooling.

⇒ output inactive: cooling  
output active: heating

$\text{delay} \leq \text{min. on time} + \text{min. off time}$
--

ZZP: ignition timing

**Pulse diagram:**

1. setting 1%  $\Rightarrow$  min. on time / max. off time

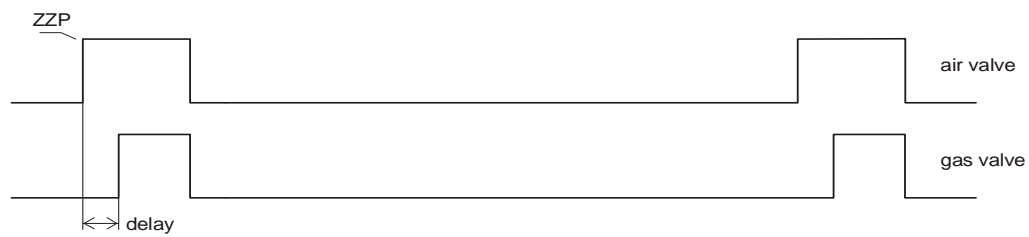

2. setting 1%...XX%  $\Rightarrow$  min. on time / off time is reduced

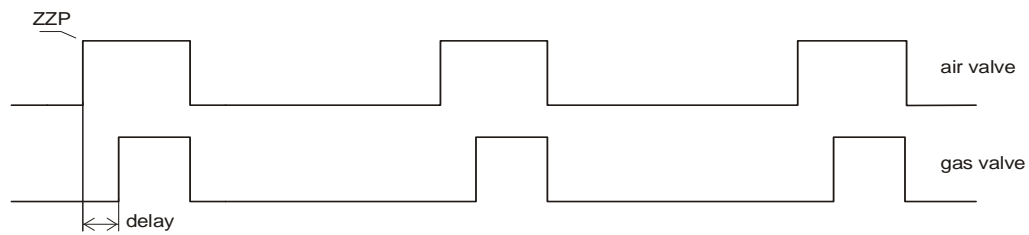

3. setting XX%  $\Rightarrow$  min. on time / min. off time maximum pulse frequency

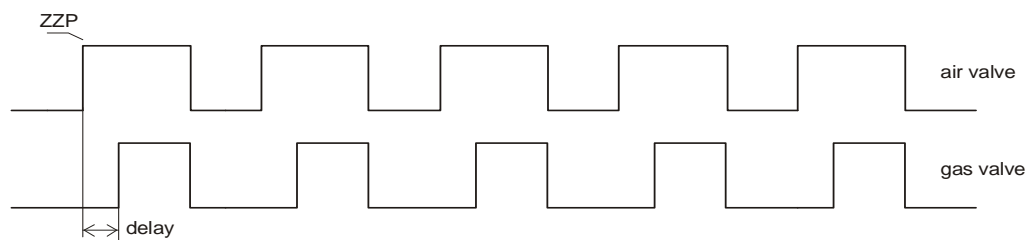

4. setting XX%...99%  $\Rightarrow$  min. off time / on time is increased

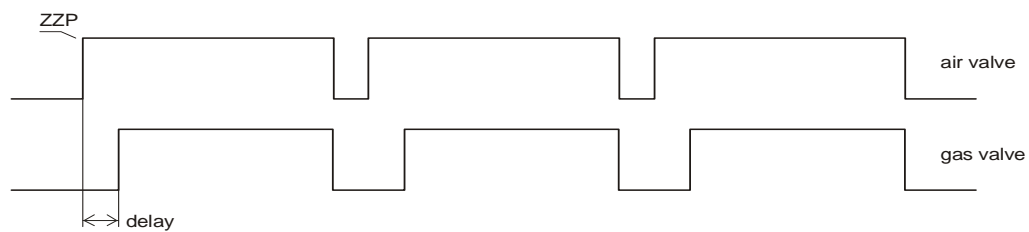

5. setting 100%  $\Rightarrow$  continuous pulse

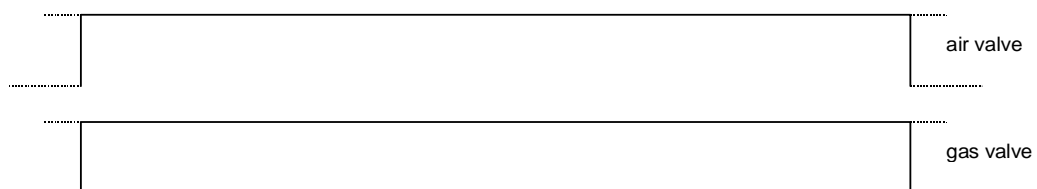

XX%  $\Rightarrow$  value in parameter 28 (10...90%)

**Adjustable parameters in mode of operation 8:**

Parameter (G1/G2)	Designation	Range	Section	Remarks
10	setting source	0...5	4.1	
11	mode of operation	1...8	4.2	
12/13	equipment address	1...32	4.3	not relevant for operation
14	setting indicator	0...2	4.4	
15/16	number of outputs	0...8	4.5	
18	MPT mode	108/128	4.6	
19	keyboard repetition rate	1...32	4.7	
20,22,24,26	ZZP1, 3, 5, 7	0/1...255	0	outputs 1, 3, 5, 7
28/29	setting control factor	10...90%	4.9	
30/31	heating/cooling limit	10...90%	0	
32/33	heating/cooling dead zone	0...50%	4.11	
34/35	continuous pulse	0/50...100%	4.12	0% ⇔ no continuous pulse
36/37	control rate	1...180s	4.13	only for TPS unit
38/39	fixed setting	0/1...100%	4.14	optional 0% ⇔ no fixed setting
48/54	min. on time	50ms...160s	4.15	parameter set 1
49/55	min. off time	50ms...160s	4.17	parameter set 1
50-53/56-59	delay	10ms...20s	4.18	parameter set 1
68/74	min. on time	50ms...160s	4.15	parameter set 2
69/75	min. off time	50ms...160s	4.17	parameter set 2
70-73/76-79	delay	10ms...20s	4.18	parameter set 2
87	equipment code	0/1...255	4.19	0 ⇔ no equipment code

ZZP: ignition timing

TPS: three-point step controller

## 4 Adjustable parameters 10...87

The following paragraphs give a detailed explanation of the adjustable parameters of the unit.

Please start by selecting a mode of operation (section 3) and then set the parameters of the MPT 700 to the values required for the mode of operation selected.

If possible, do not change any parameters while the unit is in operation (except using the function "parameter set 2"). Otherwise, inadmissible parameter values may cause malfunctions.

A Complete list of all parameters is included in section 5.3.3.

### 4.1 Parameter 10 - setting source

- Range of values: 0...5
- Depending on the active setting source indicator (off, 1...4), this parameter defines the source of the setting in NORMAL OPERATION and in the event of a FAULT.

Parameter value	VWD = off	VWD = 1	VWD = 2	VWD= 3/4
0	off	off	off	Off
1	off	0...20	0...20	Manual
2	off	4...20/off	4...20/off	Manual
3	off	TPS	TPS	Manual
4	off	manual	4...20/manual	Manual
5	off	off	off	Manual

VWD: number of active setting source indicator

TPS: 3-point step controller

If the unit is switched to "MANUAL" or "TPS" in the event of a fault, the last valid setting is used

#### Example:

setting source 1: mA input

setting source 2: off

active setting source: 01

parameter 10: 2

⇒ normal operation: 4-20 mA continuous controller

mA fault: all outputs are reset

If this controller also fails (<2mA or > 20,7mA in (4...20mA) operation as well as > 20,7mA in (0...20mA) operation), all outputs are reset.

## 4.2 Parameter 11 - mode of operation

Range of values: 1...8

- The value of this parameter corresponds to the mode of operation selected (see section 3).

## 4.3 Parameter 12, 13 - equipment address

- The equipment address is not relevant for operation. Indeed, all the units can even be set to the same number with no adverse effects on operation.
- Range of values: 1...32

## 4.4 Parameter 14 - setting indicator

- Range of values: 0...2
- If this parameter is set to "0", the setting indicator is switched between group 1 and 2 and vice versa at intervals of 3 sec.
- If "1" or "2" is selected, only the setting of the corresponding group is indicated.
- This parameter is only relevant in operation with a controller. In the case of manual input, the setting of the group currently selected is always indicated.

## 4.5 Parameters 15, 16 - number of outputs

- Range of values: 0...8
- Parameter 15 - group 1 outputs  
Parameter 16 - group 2 outputs
- **The total number of outputs connected must not exceed 8. Otherwise, the unit will signal a failure and all four setting source LEDs will flash.**
- See also section 4.6 for restrictions on the number of outputs available in mode 108.



## 4.6 Parameter 18 - MPT mode

- Admissible values: 108 or 128
- If parameter 18 is set to 108, the software of the MPT 700 emulates a MPT 608 unit.  
In MPT 608 mode, 8 switching outputs are available. In modes of operation 2 and 4 only 6 outputs can be used for burner control. Outputs 7 and 8 are then used for switchover between heating and cooling.
- If parameter 18 is set to 128, 8 outputs are available for burner control in all modes of operation.  
The outputs heating/cooling 1 and heating/cooling 2 are then used for switchover between heating and cooling.
- Depending on the application, it may be necessary to adjust the burner ignition timings (see section 0)

## 4.7 Parameter 19 - keyboard repetition rate

- Range of values: 1...32
- Parameter 19 defines the repetition rate of the keyboard (from 1 to 32 changes per second) when editing individual parameters.

## 4.8 Parameters 20...27 - ignition timing, channels 1...8

- Range of values: 0, 1...255
- Each cycle includes 255 possible ignition timings.
- The ignition timing is the point in the cycle when the appropriate output is activated.
- The value "0" must be set for outputs which are not connected or are not intended to be controlled.
- If the pulse frequency is changed, the spacing of the ignition timings is changed, but not the relationship between them.
- The maximum pulse frequency is a function of the values set for pulse width, maximum on time, minimum off time and the mode of operation (see section 3).
- For this reason, it is not possible to state the ignition timing as an absolute value in time units.

Example: If the second output is set to an ignition timing of 128, the output is always activated in the middle of the cycle. Only the length of the cycle is changed.

- Clock diagram:

- The circumference of the circle corresponds to the cycle duration ( 1/ frequency).
- The larger the circumference, the lower the frequency.

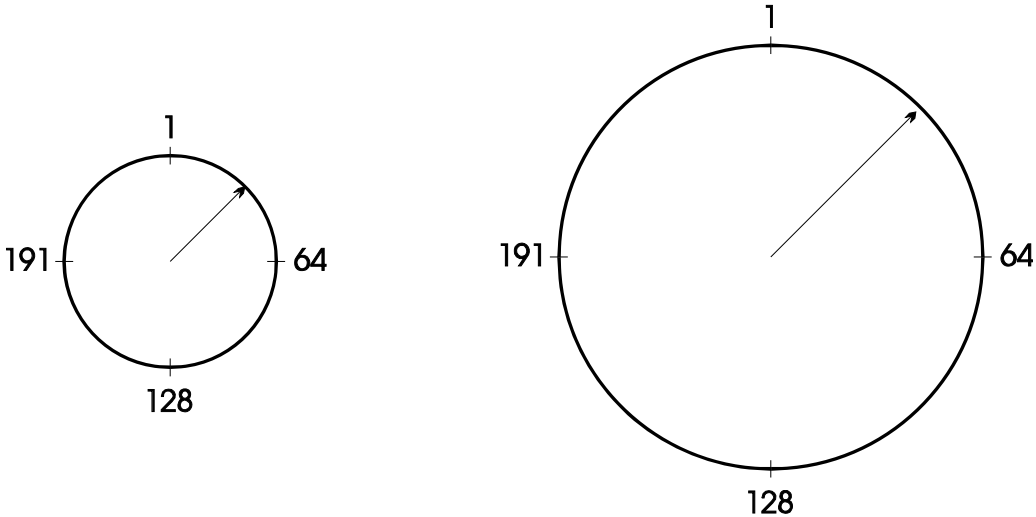

- If the ignition timings are evenly distributed, the following method can be used for calculations.

output 1 = 1  
 output 2 = (255 / number of outputs) \* 1  
 output 3 = (255 / number of outputs) \* 2  
 output 4 = (255 / number of outputs) \* 3

- Example: number of outputs = 4

ignition timing 1:	1
ignition timing 2:	64
ignition timing 3:	128
ignition timing 4:	191
ignition timing 5-8:	0

- If necessary, the ignition timings can be set to any value between 1 and 255.

- Table for 1...8 outputs with even distribution of ignition timing:

Output	Parameter	Number of outputs used							
		1	2	3	4	5	6	7	8
1	20	1	1	1	1	1	1	1	1
2	21	0	128	85	64	51	43	36	32
3	22	0	0	170	128	102	85	73	64
4	23	0	0	0	191	153	128	109	96
5	24	0	0	0	0	204	170	146	128
6	25	0	0	0	0	0	213	182	160
7	26	0	0	0	0	0	0	219	192
8	27	0	0	0	0	0	0	0	224

#### 4.9 Parameter 28, 29 - setting control factor

- This parameter is effective in modes of operation 3, 4, 7, 8
- Range of values: 10...90 % in steps of 1 %
- This parameter defines the setting (10...90 %) at which maximum frequency (min. on time, min. off time) is reached.
- By adjusting this value, it is possible to make the control setting/burner output characteristic a linear function.

#### 4.10 Parameter 30, 31 - heating/cooling limit

- This parameter is effective in modes of operation 2, 4, 6, 8
- Range of values: 10...90 % in steps of 1 %
- This parameter defines the setting value in per cent at which switchover from heating to cooling and vice versa is effected.

#### 4.11 Parameter 32, 33 - heating/cooling dead zone

- This parameter is effective in modes of operation 2, 4, 6, 8
- Range of values: 0...50% in steps of 1%
- The value selected is distributed symmetrically around the heating/cooling limit (parameter 30, 31).

**Example:**

Parameters entered: heating/cooling limit  $\Rightarrow$  50%  
 dead zone  $\Rightarrow$  10%

Working areas: cooling 0...45%  $\Leftrightarrow$  -100 ... 0 % output  
 heating 55...100%  $\Leftrightarrow$  0 ... +100 %  
 output  
 dead zone 45...55%  $\Leftrightarrow$  0 % output

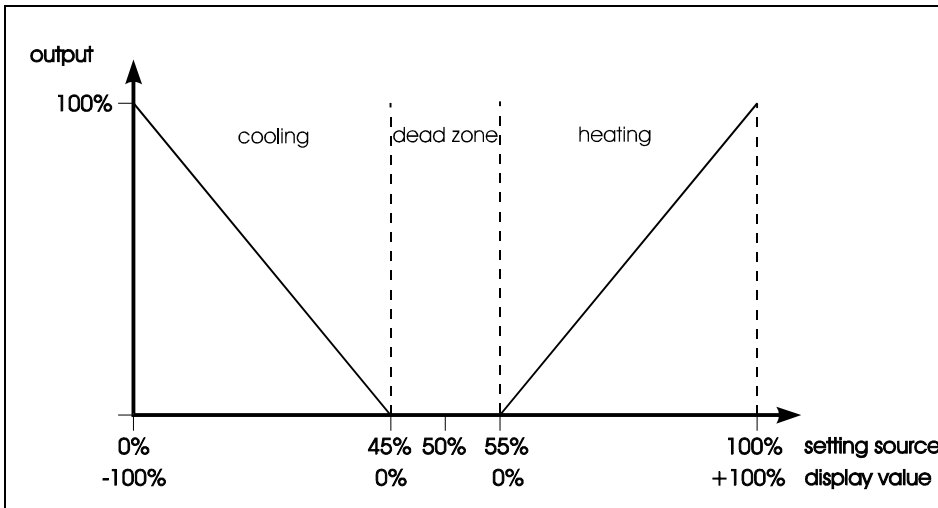

- If this parameter is set to 0%, corresponding to no dead zone, there is an abrupt switchover between heating and cooling.

$\Rightarrow$  In the event of fluctuations in the setting around the heating/cooling limit, the unit will therefore switch repeatedly between heating and cooling.

A small dead zone should therefore be set.

- **CAUTION: heating/cooling limit and dead zone for 0/4...20mA controllers**

1. Limit: The limit is given by the useful range of the controller.

Example: limit = 50%

0...20mA controller: 50% of 20mA (limit at 10mA)

4...20mA controller: 50% of 16mA (limit at 12mA)

2. Dead zone: The dead zone is also determined by the useful range of the controller.

Example: dead zone = 10% / H/C limit = 50%

0...20mA controller: 10% of 20mA  $\Rightarrow$  dead zone = 2mA

$\Rightarrow$  0mA...9mA  $\Rightarrow$  cooling  
 9mA...11mA  $\Rightarrow$  dead zone  
 11mA...20mA  $\Rightarrow$  heating

4...20mA controller: 10% of 16mA  $\Rightarrow$  dead zone = 1.6mA

$\Rightarrow$  4.0mA...11.2mA  $\Rightarrow$  cooling  
 11.2mA...12.8mA  $\Rightarrow$  dead zone  
 12.8mA...20.0mA  $\Rightarrow$  heating

#### 4.12 Parameter 34, 35 - continuous pulse

- Range of values: 0, 50...100% in 1% steps
- Value = 0  $\Rightarrow$  no continuous pulse

i.e. at 100% control setting, the unit operates at maximum frequency without switching to continuous pulse.

- Value = 50...100% (from the value entered, all outputs are set to continuous pulse)

#### 4.13 Parameter 36, 37 - control rate (three-point step controller)

- Range of values: 1...180s in 1s steps
- The control rate indicates the time taken for changing the signal from 0 to 100%.

Example: control rate = 30s  
 current setting = 50%  
 signal three-point step controller = OPEN

$\Rightarrow$  time required from 50...100% = 15s

#### 4.14 Parameter 38, 39 - fixed setting

- This parameter is effective in modes of operation 1 ... 8
- Range of values: 0, 1...100% in 1% steps
- The fixed setting is used for special purposes such as reduction.
- Depending on the signal at INPUT 1 and INPUT 2 the unit is either operated at the setting received from the controller or at the fixed setting stored in parameter 38, 39.

INPUT 1/3 inactive    ⇒ controller setting

INPUT 1 active        ⇒ fixed setting for group 1

INPUT 3 active        ⇒ fixed setting for group 2

**CAUTION:** If the parameter is set to 0,  
⇒ no fixed setting is valid even if INPUTS 1/3 are active

#### 4.15 Parameters 40...47 / 60...67 - pulse widths

- These parameters are effective in modes of operation 1, 2, 5, 6
  - Range of values: 50ms...160s
- The pulse width can be set separately for each channel.

Range	Step
0.050s...0.500s	0.005s
0.500s...1.000s	0.025s
1.000s...10.000s	0.100s
10.000s...60.000s	0.250s
60.000s...120.000s	0.500s
120.000s...160.000s	1.000s

#### 4.16 Parameters 48, 54, 68, 74 - minimum on time

- These parameters are effective in modes of operation 3, 4, 7, 8
- Range of values: 50ms...160s (for steps, see section 4.15)
- In case of Kromschröder burner control boxes, assuming that the main gas flow is only released when safety delay has elapsed:

min. on time > waiting period + safety delay

- For further details, see the subsections dealing with modes of operation 3, 4, 7, 8

#### 4.17 Parameters 49, 55, 69, 75 - minimum off time

- Range of values: 50ms...160s (for steps, see section 4.15)
- The minimum off time must always be set.
- The minimum off time always refers to 100 % control setting.
- The maximum pulse frequency available can be calculated from the minimum off time and the maximum pulse width set or the minimum on time.

Example: max. pulse width: 400 ms  
 min. on time: -  
 min. off time: 100 ms

⇒ min. cycle time: 500 ms  
 ⇒ max. frequency: 2 Hz

This applies to 100% control setting without continuous pulsing.

#### 4.18 Parameters 50...53 / 56...59 / 70...73 / 76...79 - delays

- These parameters are effective in modes of operation 5 ... 8
- Range of values: 0.01 s...1 s in 0.01 s steps  
 1.00 s...20 s in 0.10 s steps
- For further details, see the subsections dealing with modes of operation 5 ... 8.

## 4.19 Parameter 87 - equipment code

- Range of values: 0, 1...255
- The equipment code prevents unintentional or unauthorized changes in parameters.
- The equipment code can be set by the manufacturer as required by the customer prior to delivery.
- If the equipment code is set to 0 (the standard setting), all parameters can be changed at any time without entering a code number.
- If the equipment code is set to any other value (between 1 and 255), parameter 87 must be selected and the valid equipment code entered before any parameter can be changed.
- After the correct code number has been entered, parameters can be changed until the parameter number display has shown a value between 0 and 4 for more than 5 seconds.



## 5 Appendix

### 5.1 Installation

#### 5.1.1 Proper use

The MPT 700 burner cycle control unit is intended as a component for the control of between 1 and 8 burner control boxes or relays for the control of industrial burners in industrial furnace systems.

**The MPT 700 is not a safety device. The outputs of this impulse system may not be used for safety-related tasks (e.g. opening valves).**

The MPT 700 burner cycle control unit is an electrical component for installation in a switchgear cabinet. It must be operated in a closed housing providing adequate protection against direct or indirect contact with live parts.

The MPT 700 burner cycle control unit is not a domestic appliance but is designed for industrial use. The unit must not be used in domestic accommodation or on trade or commercial premises without obtaining the prior written permission of the manufacturer.

Compliance with the specifications concerning supply voltages, control inputs and outputs and climatic conditions (5.5) is essential.

#### 5.1.2 Installation notes and safety precautions

***The user is responsible for ensuring compliance with the EMC legislation in the specific application.***

The burner cycle control unit contains components which may be damaged by electrostatic charges. Before handling an open unit or working on or near equipment connections, personnel must discharge any electrostatic charges (for example by touching a grounded bare metal screw or surface).

If any equipment not in accordance with the requirements of European Standard EN50081-1:1992 as regards interference immunity is operated in the vicinity of the burner cycle control unit, the possibility of electromagnetic interference on such equipment cannot be excluded. Similarly, the burner cycle control unit may be affected by interference from equipment not meeting the interference emission limits of European Standard EN61000-6-2.

The conformity of a plant with CE requirements depends on the installation configuration and the care taken in installation. Special attention must be paid to shielding and grounding.

### 5.1.3 General

A decisive factor in protection against electromagnetic interference is the correct shielding and grounding of cables. Both ends of the shield must be connected to a grounded surface over as large an area as possible using cable clamps or PG-skin glands.

Where possible, the positive and negative terminals of unused control inputs should be connected to each other inside the connector.

The various functional units of the MPT 700 burner pulse control unit are isolated from each other and have no common ground connection (see section 5.2: block diagram and terminal plan). In accordance with the standards for low-voltage systems, you can therefore set the reference voltages as required for 1mm creepage and air gaps between functional units and 3mm between each functional unit and the mains connection.

Please take note of the following paragraphs before commissioning the unit.

### 5.1.4 Ground connection

To ensure safe operation of the MPT 700 burner cycle control unit, a ground (PE) conductor with a cross section of at least 0.75mm<sup>2</sup> must be connected to contacts 32zbd (VDE0100). The ground conductor may form part of the AC feeder cable.

Ground connection:

Contacts: PE 32zbd

Cross section:  $\geq 1.5\text{mm}^2$

Cable type: non-shielded

### 5.1.5 Power supply connections

For operation of the MPT 700 burner cycle control unit, a power supply with a voltage of 95...240V, 50...60Hz must be connected to contacts 28zbd (N) and 30zbd (L). If possible, the power supply should be taken from a power supply network for control equipment (class 3 or better).

Power supply connection 95...240VAC, 50...60Hz, 250mA:

Contacts: N 28zbd  
L 30zbd

Cross section:  $\geq 0.75\text{mm}^2$

Cable type: non-shielded

For switching outputs (section 5.1.8) a DC power supply (voltage 12...24V) must be connected to contacts 2b+4b (+Vcc) and 10b+12b (GND). Depending on the requirements for the switching outputs, either a non-voltage-controlled or a voltage-controlled DC network (class 3 or better) may be used.

The DC power supply should be switched together with the mains voltage.

DC connection 12..24VDC, 1.1A:

Contacts: +Vcc 2b+4b  
GND 10b+12b

Cross section:  $\geq 0.75\text{mm}^2$

Cable type: non-shielded

Non-shielded cables with a conductor cross section of at least 0.75mm<sup>2</sup> and an adequate voltage rating must be used for power supply connections.

### 5.1.6 Binary control inputs

For connection to the binary control inputs (optocouplers) at contacts 14zbd, 16zbd and 18zbd, shielded conductors with a cross section of at least  $0.25\text{mm}^2$  must be used. These conductors may be combined with other control circuit conductors of the same type in cables.

The load on each binary control input is  $2,7\text{k}\Omega$ .

Binary control inputs 0/12...24VDC:

Contacts:	+ IN 1	14z	(active = fixed setting 1)
	+ IN 2	14d	(active = parameter set 2)
	+ IN 3	16z	(active = fixed setting 2)
	+ IN 4	16d	(active = group 2)
	- IN 1...4	14b+16b	
	+ TPS-INCR.	18z	(active = INCREASE)
	+ TPS-DECR.	18d	(active = DECREASE)
	- TPS-INCR., - TPS-DECR.	18b	

Cross section:  $\geq 0.25\text{mm}^2$

Cable type: shielded

In operation with two groups, the three-point step inputs must be multiplexed using an external pulse relay. The group currently controlled is determined by binary input 4.

***Please read sections 5.2.1 and 5.2.3 and check whether jumper 501 has been correctly set for your configuration.***

### 5.1.7 mA control inputs

Connections to the mA control inputs (contacts 20zbd) must be made using shielded or twisted pair conductors with a cross section of at least  $0.50\text{mm}^2$ . These conductors may be combined with other control circuit conductors of the same type in cables.

***The two mA control inputs have a common ground.***

The load on the two mA control inputs is  $200\Omega$ .

mA control inputs 0/4...20mA:

Contacts:	+ mA 1	20z
	+ mA 2	20d
	- mA 1, - mA 2	20b

Cross section:  $\geq 0.50\text{mm}^2$

Cable type: shielded

**Please read sections 5.2.1 and 5.2.3 and check whether jumpers 500 and 501 have been correctly set for your configuration.**

### 5.1.8 Switching outputs

For the switching outputs, i.e. the 8 burner outputs, the 2 heating/cooling outputs and the malfunction outputs (contacts 2zd, 4zd, 6zd, 8zd, 10zd, 12z) conductors with a cross section of at least  $0.50\text{mm}^2$  must be used, depending on load and cable length. For the return circuits to contacts 6b and 8b, conductors with a cross section of at least  $0.75\text{mm}^2$  must be used. These conductors may be combined with other control circuit conductors of the same type in cables.

**No voltage may be applied to the outputs.**

The common return circuit depends on the power supply (section 5.1.5). Depending on the model, the return circuit is identical with +Vcc (model M) or GND (model P).

**The total load current on all switching outputs must not exceed 1.1A. The maximum admissible load current on each switching output is 100mA. Switch outputs are not fused and are not protected against short circuits. Overloading of one or more outputs may damage or destroy the unit!**

Switching outputs:

Contacts:	burner 1	2z	(active = burner on)
	burner 2	2d	(active = burner on)
	burner 3	4z	(active = burner on)
	burner 4	4d	(active = burner on)
	burner 5	6z	(active = burner on)
	burner 6	6d	(active = burner on)
	burner 7	8z	(active = burner on)
	burner 8	8d	(active = burner on)
	heating/cooling 1	10z	(active = heating on)
	heating/cooling 2	10d	(active = heating on)
	malfunction	12z	(active = no malfunction)
	return	6b+8b	

Cross section:  $\geq 0.50\text{mm}^2$  for switching outputs (depends on load and cable length)  
 $\geq 0.75\text{mm}^2$  for return conductors

Cable type: shielded

## 5.2 Connection Plans

### 5.2.1 Main board

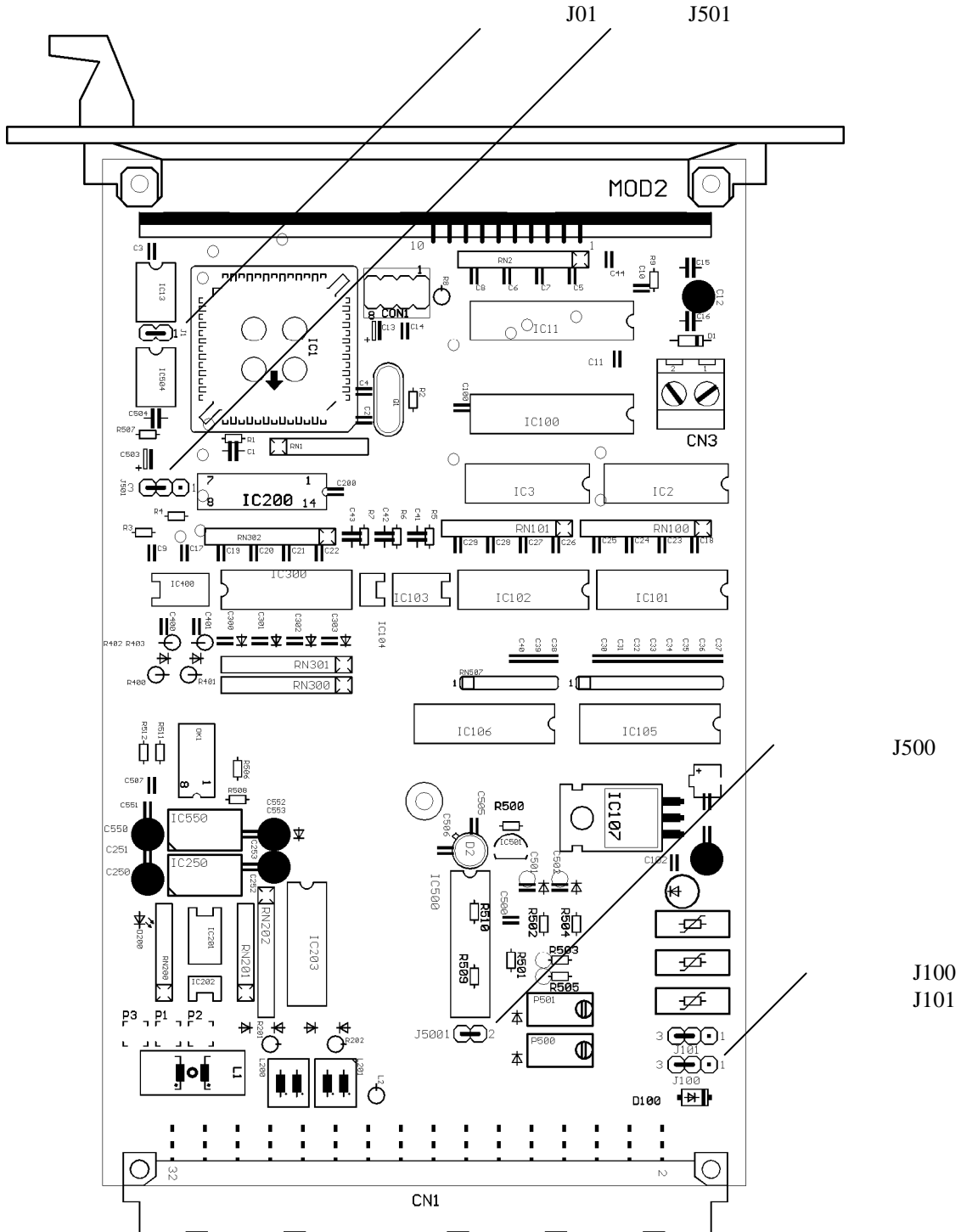

## 5.2.2 Power supply board

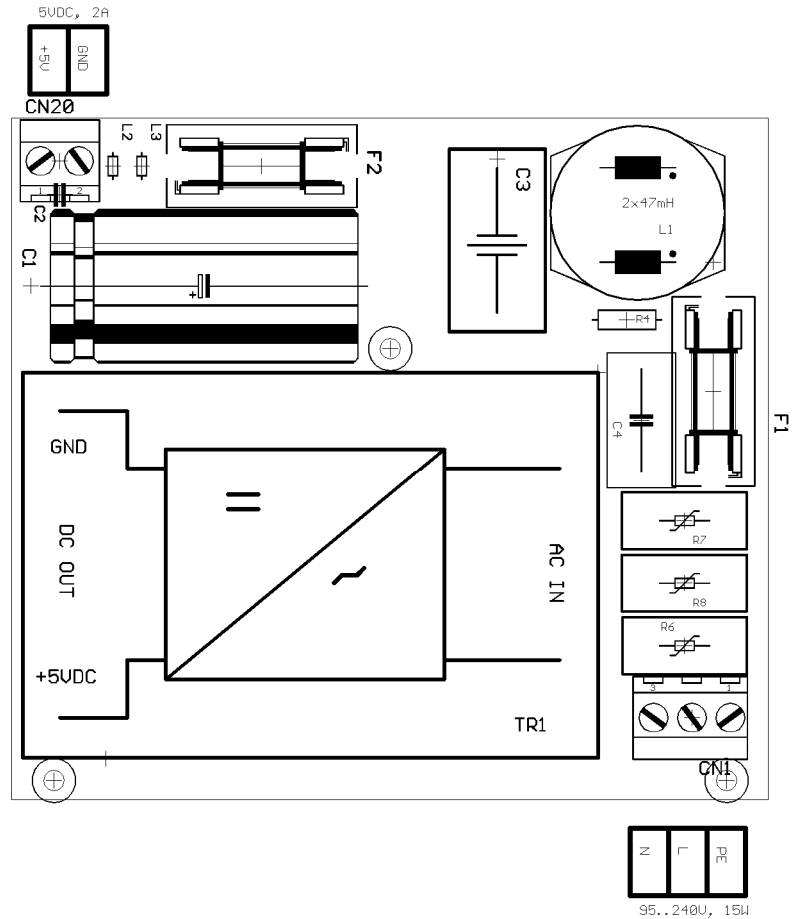

**Caution - danger of injury or death!**

***Please follow the installation instructions given in section 5.1.  
The MPT 700 is an open module which must not be operated without a housing fit for the purpose.***

### 5.2.3 Jumpers (on main board)

J01, J100, J101: fixed factory setting  
The setting must *not* be changed by the customer.

J500: set (bridged) at the factory  
The jumper *may* be opened by the customer if only one-group operation is required.

J501: set at the factory(bridge 2-3)  
**must** be set by the customer to bridge 1 and 2 if mA input 1 or the three-point step input is to be switched between groups 1 and 2 by an external pulse relay.

### 5.2.4 Fuses (on power supply board)

F1:	primary fuse:	1,0 A T
F20:	secondary fuse:	0,5 A T



### 5.2.5 Block diagram (overview)

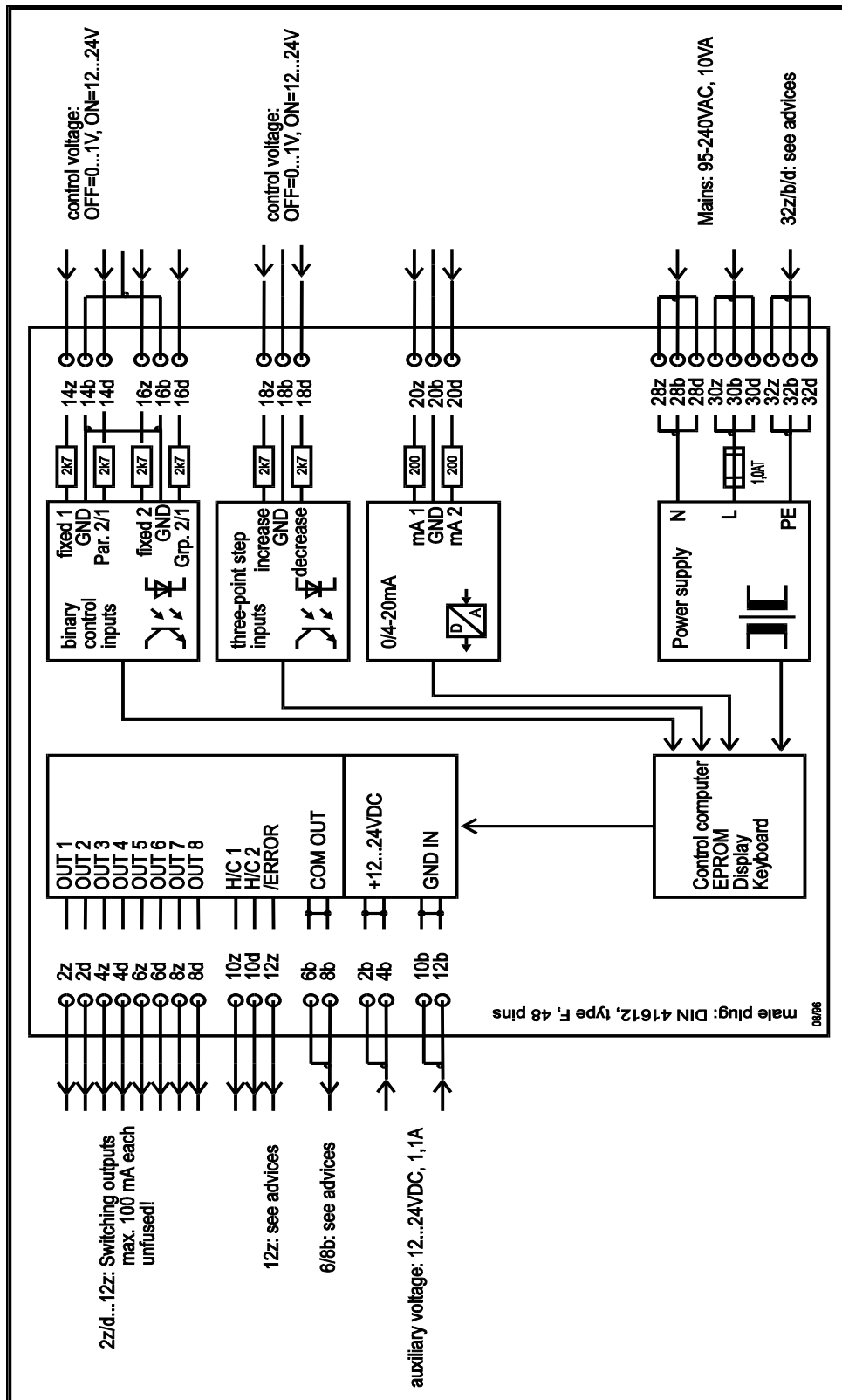

**WARNING:**  
 Before commissioning the MPT 700 for the first time, check whether the power supply is connected to the **lower** three rows of contacts.

**Notes:**

- The blocks shown are isolated from each other.
- The jumpers shown must be installed directly on the connector.
- Preferably shielded cables should be used. The shield must be grounded at both ends.
- The loads to be switched must be connected between 6/8b and the appropriate output.
- Output 12z must be wired to ensure that the plant concerned is set to a safe condition in the event of a fault.
- For the control of contacts 14z/d...18z/d via relays, the auxiliary voltage on 2/4b and 10/12b may be used (jumper 10/12b-14/16b or 10/12b-18b, relay contact between 2/4b and the input concerned).
- Unused inputs must be connected to the appropriate GND contact.
- Contacts 32z/b/d must be connected to the PE (ground) conductor (VDE 0100)!
- Please follow the notes in section 5.1!

**5.2.6 Terminal plan (CN1)**

Type F	Z	B	d
2	OUT 1	+12...24 VDC	OUT 2
4	OUT 3	+12...24 VDC	OUT 4
6	OUT 5	COM OUT	OUT 6
8	OUT 7	COM OUT	OUT 8
10	OUT H/C 1	GND	OUT H/C 2
12	OUT /ERROR	GND	reserved
14	IN 1 - fixed setting 1	IN1-4 GND	IN 2 - parameter set 2/1
16	IN 3 - fixed setting 2	IN1-4 GND	IN 4 - group 2/1
18	IN TPS-INCR.	TPS GND	IN TPS-DECR.
20	IN mA 1	mA GND	IN mA 2
22	Reserved	Reserved	reserved
24	Reserved	Reserved	reserved
26	Reserved	Reserved	reserved
28	N	N	N
30	L	L	L
32	PE	PE	PE

## 5.3 Brief instructions

The following paragraphs give a brief survey of the most important settings and all parameters.

### 5.3.1 Modes of operation

No.	Mode of operation	Section
1	Heating with fixed pulse width and variable frequency	3.1
2	Heating/cooling with fixed pulse width and variable frequency	3.2
3	Heating with variable pulse width and spacing	3.3
4	Heating/cooling with variable pulse width and spacing	3.4
5	Heating with fixed pulse width and separate air and gas valve control	3.5
6	Heating/cooling with fixed pulse width and separate air and gas valve control	3.6
7	Heating with variable pulse width and spacing and separate air and gas valve control	3.7
8	Heating/cooling with variable pulse width and spacing and separate air and gas valve control	3.8

### 5.3.2 Parameter 10 - setting source

- Together with the active setting source indicators (off, 1...4), this parameter defines the source of the setting in NORMAL OPERATION and in the event of a FAULT.

Parameter value	VWD= off	VWD=1	VWD=2	VWD=3/4
0	off	off	off	off
1	off	0...20	0...20	manual
2	off	4...20/off	4...20/off	manual
3	off	TPS	TPS	manual
4	off	manual	4...20/manual	manual
5	off	off	off	manual

VWD: number of active setting source indicator

TPS: 3-point step controller

- If the unit is switched to "MANUAL" or "TPS" in the event of a fault, the last valid setting is used.

## 5.3.3 Parameters 0...99

Parameter (G1/G2)	Designation	Range	Section	Remarks
0	control: OFF	0	2.2.2	
1	control: computer	-100...100		no function
2	control: mA/TPS	-100...100	2.2.2	
3	control: manual (G1)	-100...100	2.2.2	
4	control: manual (G2)	-100...100	2.2.2	
5	mA level/phase	hex coded	5.4.1	service parameter
6	binary control inputs	hex coded	5.4.2	service parameter
7	control outputs	hex coded	5.4.3	service parameter
8	error parameter number	coded	5.4.4	service parameter
9	error code	hex coded	5.4.5	service parameter
10	setting source	0...5	4.1	
11	mode of operation	1...10	4.2	
12/13	equipment address	1...32	4.3	Not relevant for operation
14	setting indication	0...2	4.4	
15/16	number of outputs	0...8	4.5	$P15 + P16 \leq 8$
18	MPT mode	108/128	4.6	
19	keyboard repetition rate	1...32	4.7	
20-27	ZZP1...ZZP8	0/1...255	0	
28/29	setting control factor	10...90%	4.9	
30/31	heating/cooling limit	10...90%	0	
32/33	heating/cooling deadzone	0...50%	4.11	
34/35	continuous pulse	0/50...100%	4.12	0% = no continuous pulse
36/37	control rate	1...180s	4.13	only for TPS unit
38/39	fixed setting	0/1...100%	4.14	binary input 1
40...47	pulse widths	50ms...160	4.15	parameter set 1
48/54	min. on time	50ms...160	4.16	parameter set 1
49/55	min. off time	50ms...160	4.17	parameter set 1
50-53/56-59	delay	10ms...20s	4.18	parameter set 1
60-67	pulse widths	50ms...160	4.15	parameter set 2
68/74	min. on time	50ms...160	4.16	parameter set 2
69/75	min. off time	50ms...160	4.17	parameter set 2
70-73/76-79	delay	10ms...20s	4.18	parameter set 2
87	equipment code	0/1...255	4.19	0 = no equipment code
90	cold start counter	0...2048	5.4.6	service parameter
91	ROM error counter	0...2048	5.4.6	service parameter
92	RAM error counter	0...2048	5.4.6	service parameter
93	stack error counter	0...2048	5.4.6	service parameter
94	I/O error counter	0...2048	5.4.6	service parameter
95	illegal opcode counter	0...2048	5.4.6	service parameter
96	watchdog error counter	0...2048	5.4.6	service parameter
97	clock monitor fail counter	0...2048	5.4.6	service parameter
98	EEPROM error counter	0...2048	5.4.6	service parameter
99	display test	-	5.4.7	service parameter

ZZP: ignition timing

TPS: three-point step controller

- Binary input 2 is used for switchover between parameter sets 1 and 2:

INP. 2 = 0V                   ⇒ parameter set 1  
INP. 2 = +12...24V       ⇒ parameter set 2

## 5.4 Test and service instructions

This unit requires no maintenance.

In general, errors and malfunctions are indicated by flashing lamps or by a failure to issue pulses even when a setting is available.

**The main causes of problems when commissioning the unit for the first time are incorrect terminal allocation and inadmissible parameter settings.**

If it is not possible to remedy a fault by following the instructions given below, please send the unit to one of our authorized dealers, giving a precise description of the problem and stating the error code (see section 5.4.5).

It must be noted that service parameters 5 to 9 are hexadecimal-coded. If several events are active, their hexadecimal codes are added.

The correspondences between the decimal ("d") and hexadecimal ("h") systems are as follows:

'0'd... '9'd ⇔ '0'h... '9'h  
'10'd ⇔ 'A'h  
'11'd ⇔ 'B'h  
'12'd ⇔ 'C'h  
'13'd ⇔ 'D'h  
'14'd ⇔ 'E'h  
'15'd ⇔ 'F'h

### 5.4.1 Parameter 5: test mA control input/phase

- The two left digits express the value of the A/D converter (0...255) in hexadecimal numbers. The decimal point indicates which input channel is be choosen. The position of the decimal point right beside the left digit represents the first channel. The position of the decimal point right beside the right digit represents the second channel.  
'00'h corresponds to a value of 0 mA and 'F0'h to a value of approx. 20 mA.  
This parameter can be used for checking the mA control input(s).
- If the input signal is changed, the value indicated should also change.
- The two digits on the right give the current phase in the cycle (0...255) in hexadecimal numbers.  
If the MPT 700 is currently pulsing, the value increases step-by-step, from '00' to 'FF'h.  
The burners are ignited when the ignition timings (parameter 20...27) are equal to the current phase.

### 5.4.2 Parameter 6: test of binary control inputs

- This parameter is indicated as a hexadecimal number. If several inputs are active at the same time, their hexadecimal codes are added.
- An 'x' indicates that the digit concerned is not relevant for this test.

#### Test table:

Indication	Meaning
x x 0 0	all inputs active
x x 0 1	INPUT 1 active
x x 0 2	INPUT 2 active
x x 0 4	INPUT 3 active
x x 8 0	INPUT 4 active (T2/V5.x) *
x C x x	buttons not in use
x 4 x x	top right button
x 8 x x	bottom right button
1 x x x	three-point step controller (-)
2 x x x	three-point step controller (+)
3 x x x	three-point step controller at rest (0)

\* switches periodically if jumpers 500 (bridged) and 501(bridge 2-3) are set.

inactive ⇒ input voltage = 0V

active ⇒ input voltage = +12...24V

### **5.4.3 Parameter 7: test of switching outputs**

- This service parameter is of no importance to customers as the relevant information is already given by the switching output indicators (see section 2.1.6).

### **5.4.4 Parameter 8: error parameter number**

- In the event of a parameter error (see section 5.4.5), the two left digits of this parameter (decimal numbers) indicate the number of the first incorrect parameter.

The two right digits of this parameter are of no importance to the customer.

### 5.4.5 Parameter 9: error code

- **Note this value and always state it when returning the unit to one of our authorized dealers.**
- The error code is displayed as a hexadecimal number. If several errors are active, their hexadecimal codes are added.
- An 'x' indicates that the digit concerned is not relevant for this test.

#### Error codes:

Value	Meaning	Indicator	Error type
0000	No error	-	-
XX01	EEPROM programming error	malfunction red	C
XX02	ROM defective	malfunction red	C
XX04	Inadmissible parameter input	malfunction red	B
XX08	CONFIG register incorrect	malfunction red	C
XX10	RAM test error (cold start)	malfunction red	C
XX20	I/O error (time protected bits)	malfunction red	C
XX40	Stack overrun (RAM check)	malfunction red	C
XX80	Watchdog	malfunction red	C
01XX	Pilot burner 1 failure	STOP	A
02XX	Pilot burner 3 failure	STOP	A
04XX	Pilot burner 5 failure	STOP	A
08XX	Pilot burner 7 failure	STOP	A
10XX	No function	01 flashes green	A
20XX	< 2 mA or > 20,7 mA in 4-20 mA operation > 20,7mA in 0...20mA operation	'mA' 02 flashes green / malfunction LED steady light	A
40XX	Reserved		
80XX	Reserved		

- **Error type A:**  
These errors are automatically reset if the cause (pilot burner failure, line break or communication failure) is remedied by the customer.
- **Error type B:**  
These errors are automatically reset, if the customer sets the parameters to values appropriate for the mode of operation.  
Type B errors may for example be signaled if the mode of operation is changed and not all the parameters are set to appropriate values.  
The number of the "first incorrect parameter" is indicated by the left two digits of parameter 8.  
Please check the values of all parameters set on the basis of the parameter list in section 3 for the mode of operation selected and the notes concerning the parameters in section 4.  
Please note that the parameter indicated as the "first incorrect parameter" may be incorrect because another parameter with a higher number has not been



---

set correctly. This will be the case if there is a functional interrelationship between the two parameters.

- **Error type C:**  
This error type is signaled if an error counter (parameter 90...98) overflows and internal error handling procedures are ineffective (see section 5.4.6).  
In the case of an equipment fault, the same error will be signaled within a short time of resetting the signal.  
If a cold start (see section 5.4.8) does not solve the problem, please return the unit to one of our authorized dealers, giving an exact description of the problem and stating the error code (parameter 9).

#### **5.4.6 Parameters 90...98: event counters**

- The event counters indicate the number of cold starts and various internal errors.
- If a counter overflows (value 2048), a malfunction is signaled (see section 5.4.5).
- The event counters may be reset to zero by pressing the bottom right button. The counters should only be reset following an overflow.

#### **5.4.7 Parameter 99: display test**

- It is possible to test each segment of the display by pressing the two buttons on the right.

#### **5.4.8 Cold start**

- Disconnect the MPT 700 from the power supply for about 10 seconds.
- Following reconnection to the power supply, the MPT 700 is reset to its normal status if no internal or external errors are active.

#### **5.4.9 Connections**

- Please check all the connections using the block diagram in section 5.2.5 and the potentials at all connections before returning the unit to one of our authorized dealers.

## 5.5 Technical specifications

Operating voltage:	110...240VAC, -15/+10%, 50/60Hz
Power required:	10VA, max. 250mA
Control voltage:	12...24VDC $\pm$ 10%, max. 1.1A
CE conformity:	EN 50081-1:1992 EN 61000-6-2:1999
Inputs:	<ol style="list-style-type: none"><li>1. 2x 0/4...20mA with common ground, potential-free load approx. 200 Ohm</li><li>2. 1x three-point step control input, potential-free 12...24VDC, load approx. 2700 Ohm</li><li>3. 4x binary inputs, common ground, potential-free 12...24VDC, load approx. 2700 Ohm</li></ol>
Outputs:	12...24VDC $\pm$ 10%, max. 100mA per channel positive logic : switched +12...24VDC: 10 open emitter outputs
Electr. connection:	48-pin contactor, Type F, DIN 41612
Design:	open unit European standard size, 100 x 160mm with 50.8 x 128.5 front panel (3 HE, 10 TE)
Working temperatures:	0...+60°C
Storage temperature:	-25...+60°C
Relative humidity:	0...80%, no condensation
Installation position:	as required
Weight:	approx. 500g



Elster GmbH  
Postfach 28 09, D-49018 Osnabrück  
Strothweg 1, D-49504 Lotte (Büren)  
T +49 541 1214-0  
F +49 541 1214-370  
info@kromschroeder.com  
www.kromschroeder.com