

COMBUSTION CONTROL ACCESSORIES OIL FLOW METERS (FMO)



Oil flow meters are used to provide instantaneous flow monitoring for applications using commercially available fuel oils.

Low capacity oil flow meters should be installed in a bypass loop for ease of maintenance and to reduce pipe stress on the flow meter body. They are limited for use with No. 2 fuel oil only and are suitable for applications up to 125 psi (860 kPa) at 70°F (21°C). Accuracy is +/-4% of full scale reading.

Low Capacity Flow Meters



Model No.	Hauck Part No.	Conn Size NPT	Minimum Flow (gph)	Maximum Flow (gph)
7520-02	70851X007	1/4	0.7	7.6
7520-04	70851X002	1/4	1.2	13
7520-06	70851X003	1/4	2.3	24
7520-08	70851X004	1/4	4.7	48
7520-10	70851X005	1/4	6.4	65

Dimensions (Inches)

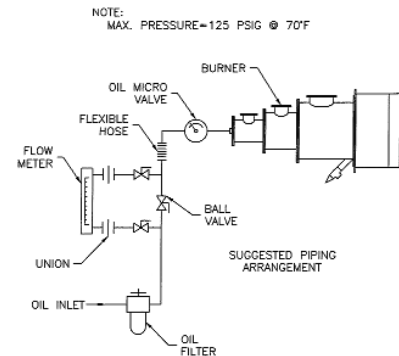
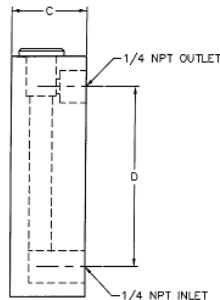
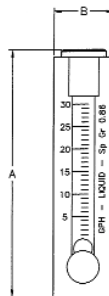

Model No.	A	B	C	D
7520-02	4 1/8	1	1 1/4	3
7520-04				
7520-06				
7520-08				
7520-10				

FMO-1