

Actuators IC 40

Product brochure · GB
3 Edition 02.16

ERC CE

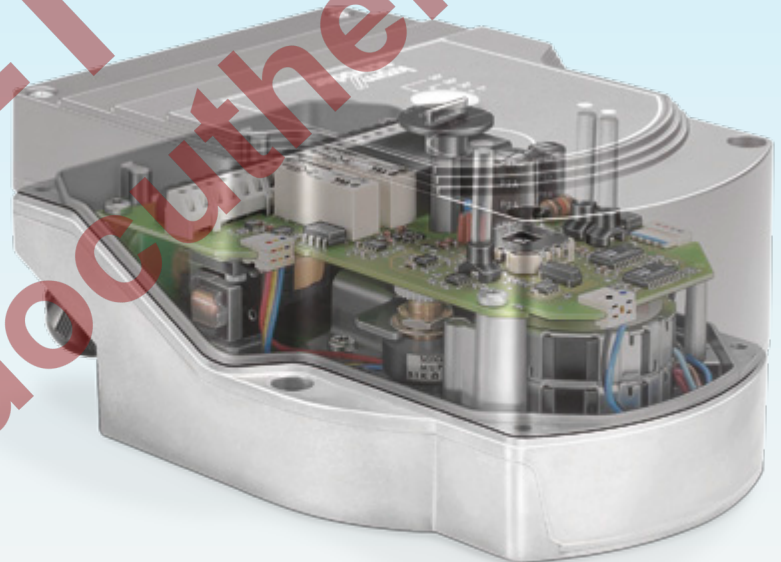

krom
schroder



- For complex applications with programmable functions for flexible adjustment to the process, with statistics and fault history to support service personnel
- Position indicator that can be read externally
- Spacious connection chamber for ease of installation
- Actuators can be delivered ready installed on butterfly valves BVG, BVGF, BVA, BVAF, BVH, BVHS or linear flow control VFC

Application

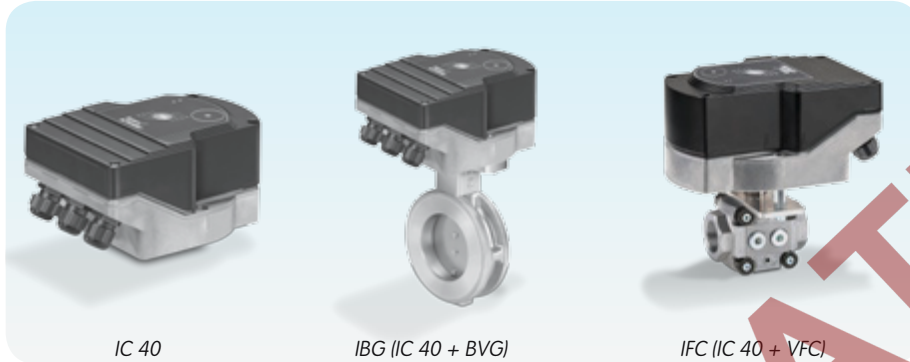

IC 40

IBG (IC 40 + BVG)

IFC (IC 40 + VFC)

Actuator IC 40 is designed for all applications that require precise, controlled rotary movement between 0° and 90°. It can be mounted directly onto the butterfly valves BVG, BVGF, BVA, BVAF, BVH, BVHS or linear flow control VFC in order to control the gas and air flow rates on gas burners.

Actuators and butterfly valves or linear flow control VFC can also be delivered ready assembled as butterfly valves with actuator IBG, IBGF, IBA, IBAF, IBH, IBHS or linear flow control IFC.

An optional integrated feedback potentiometer offers the option of monitoring the current position of the actuator. This checking function can be used in automation processes.

IC 40

The IC 40 can be used on continuously-controlled burners and on stage-controlled burners.

Settings on the actuator IC 40 can be made using a PC with the programming software BCSoft. All the relevant settings for the process are made using the software via an optical interface. Various operating modes, which may be modified, are stored in the unit. In addition, the control type (two-point signal, three-point step signal or continuous control), running times, adjustment angles and intermediate positions can be programmed.

The actuator can also be controlled "by hand" using the software.

Once set, all the parameters can be saved on the PC and copied from there into other actuators, thus saving time during the commissioning process.

Service technicians can call up statistical data using BCSoft, such as hours of operation, actuating cycles and a fault history. Some values can also be set to zero, for example to record data over a specific period of time.



Roller hearth kiln in the ceramics industry



Forging furnace

Examples of application
Staged control

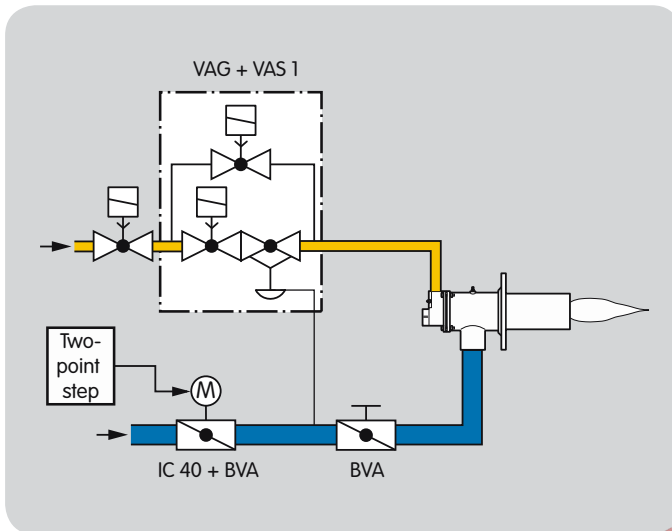

For processes that require a homogeneous temperature distribution in the furnace. The actuator IC 40 is controlled by a two-point controller and operates in On/Off or High/Low intermittent mode. The actuator closes when the voltage supply is interrupted. The running time can be adjusted between 5 and 25 seconds.

Staged control with three burner capacity levels

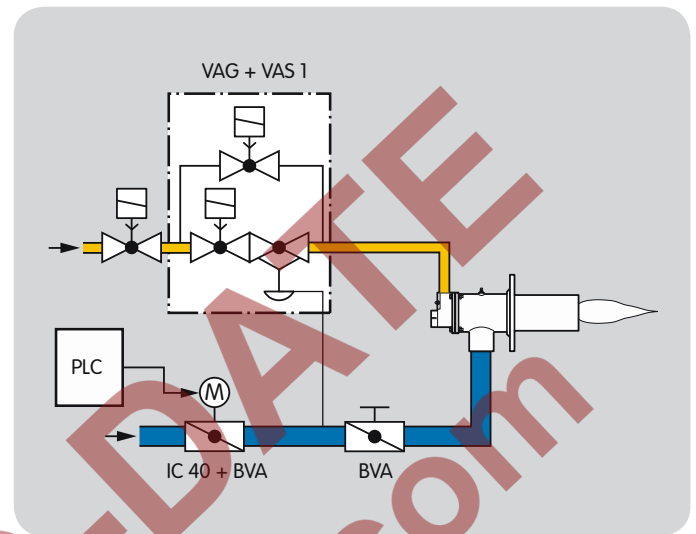

For processes that require a homogeneous temperature distribution in the furnace and three burner capacity levels. The actuator IC 40 is controlled by a programmable controller and works in High/Medium/Low or High/Medium/Low/Off intermittent mode. This allows the ignition stage to be started. The optional pressure switch provides fail-safe monitoring of the maximum pilot air volume. The actuator running time can be adjusted between 5 and 50 (75) seconds.

NOT UP-TO-DATE
www.documentation.com

Continuous control by three-point step signal

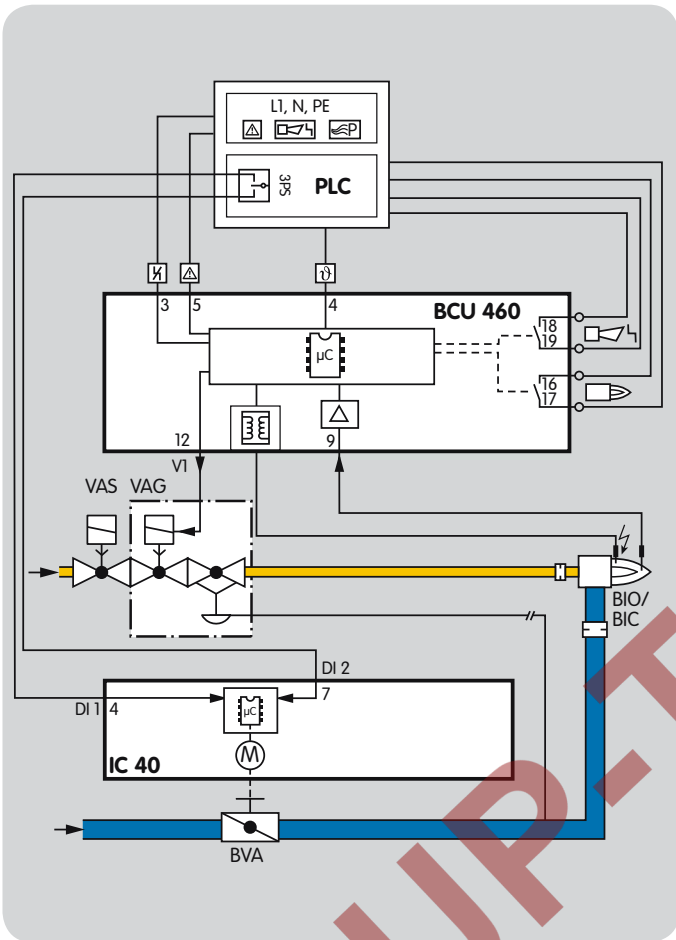

The actuator IC 40 is controlled by the three-point step controller 3PS and moves the butterfly valve BVA to the ignition position. The burner starts.

Once the burner is operating, the operation signalling contact of the burner control unit BCU 460 closes. The BCU issues the controller enable signal to the temperature controller. The butterfly valve opens or closes between the low-fire and high-fire rate positions depending on the capacity demand of the burner. When the three-point step signal is disconnected, the butterfly valve stops at its current position.

If both inputs on the IC 40 (DI 1 and DI 2) are activated after the burner has been shut down, the butterfly valve closes further than the low-fire rate position (see Operating mode 12, 3-point step operation with low position).

DI 1	DI 2	IC 40 position	Valve position
Off	Off	Idle/Stop	Idle
On	Off	Open to high position	Open to high-fire rate
Off	On	Close to middle position	Close to low-fire rate
On	On	low	Valve closes further

Staged control with pre-purge

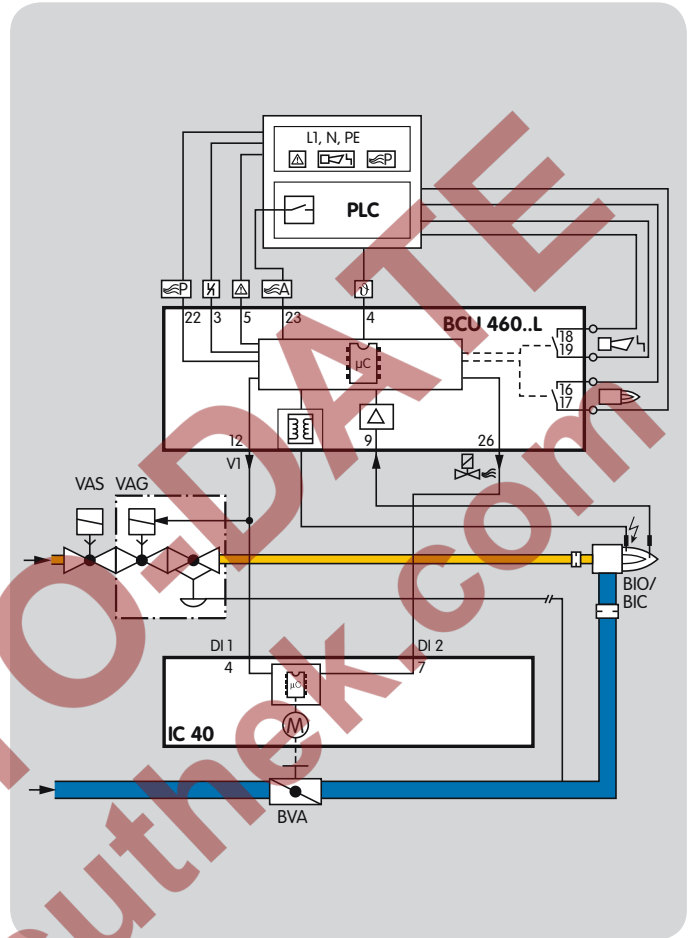

The central control system starts the pre-purge. Input DI 2 is activated via the air valve output of the BCU and the butterfly valve BVA is set to the pre-purge position.

In the event of a temperature demand, the burner control unit BCU activates input DI 1 via the valve output V1 and moves the butterfly valve to the ignition position. (Precondition: the IC 40 must have reached the ignition position on the instant of ignition.) The burner starts.

To activate the high-fire rate, DI 2 is activated via the air valve output on terminal 26 of the BCU.

The butterfly valve moves cyclically between the high-fire rate position and the low-fire rate position (see Operating mode 11, 2-stage operation with two digital inputs).

DI 1/ V1	DI 2/ air valve	IC 40 position	Valve position
Off	Off	closed	Closed
On	Off	low	Ignition position/low-fire rate
On	On	middle	High-fire rate
Off	On	high	Pre-purge

Continuous control with defined ignition position

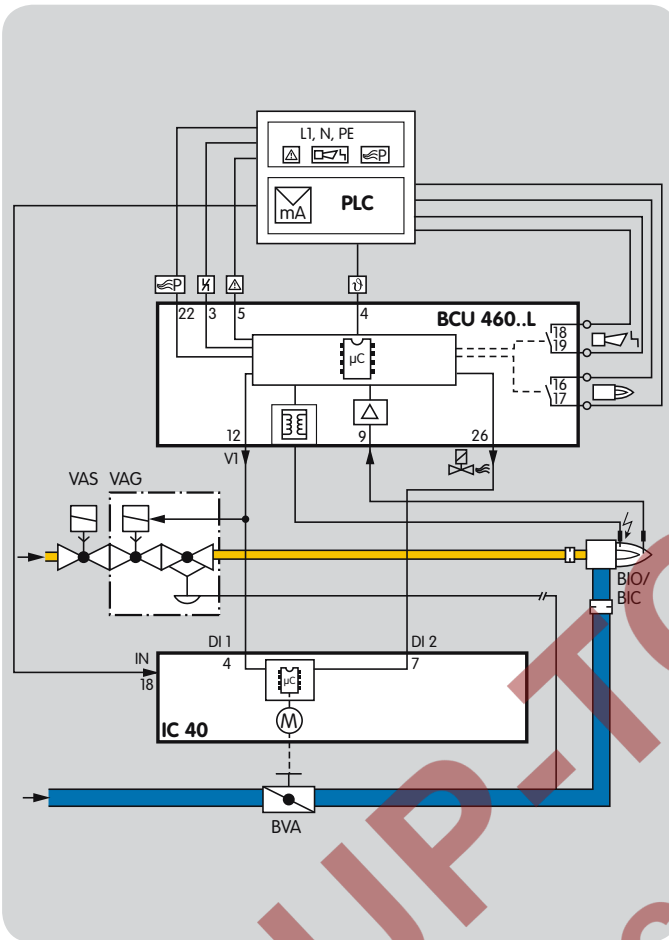

The BCU activates DI 2 via the air valve output. This enables the analogue input IN on the actuator IC 40. Depending on the capacity demand of the temperature controller, the butterfly valve BVA moves steplessly to the position between the low-fire rate and the high-fire rate as specified by the analogue input IN (see Operating mode 27, 2-stage operation with two digital inputs and variable adjustment angle) for the open position.

DI 1/ V1	DI 2/ air valve	IC 40 po- sition	Valve position
Off	Off	closed	Closed
On	Off	low	Ignition position/low-fire rate
On	On	IN	Any position between ignition position and pre-purge
Off	On	high	Pre-purge/high-fire rate

The central control system starts the pre-purge. Input DI 2 is activated via the air valve output of the BCU and the butterfly valve BVA is set to the pre-purge position.

In the event of a temperature demand, the burner control unit BCU activates input DI 1 via the valve output V1 and moves the butterfly valve to the ignition position. (Precondition: the IC 40 must have reached the ignition position on the instant of ignition.) The burner starts.

NOT FOR PUBLICATION www.cuttek.com

Hot-air compensation

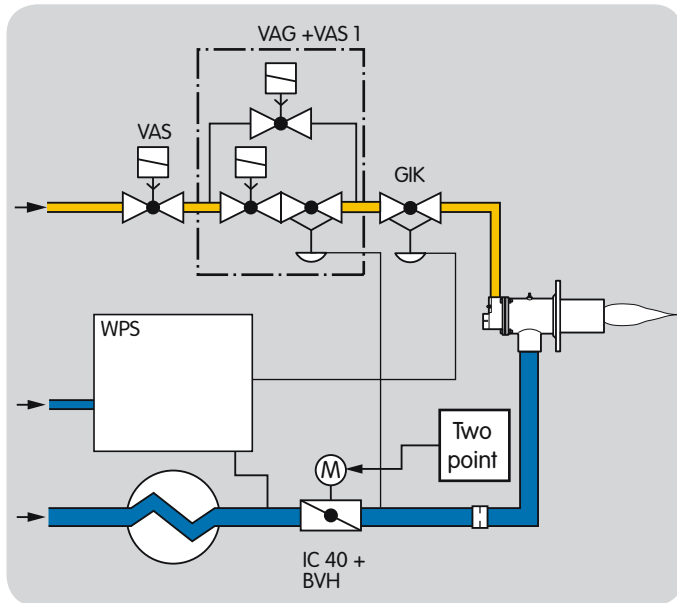

For processes in which preheated combustion air at a temperature of up to 450°C must be controlled. In this example, the actuator IC 40 is regulated by a two-point controller to adjust the burner capacity. It runs in High/Low intermittent mode. The running time can be adjusted between 5 and 25 seconds.

Staged control with online adjustment of the burner capacity

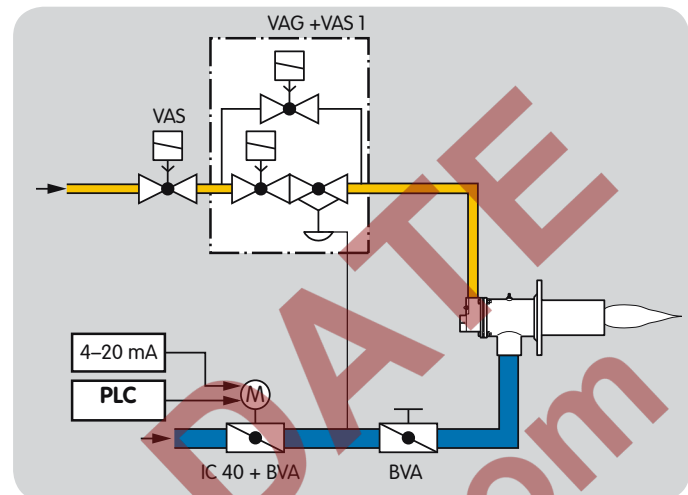

For processes that require a homogeneous temperature distribution and high temperature accuracy in the furnace.

If only a low heat output is required, for example to maintain the temperature in the furnace, the burner can continue to be operated in intermittent mode. The adjustment angle of the valve is reduced via the analogue input (4–20 mA) of the actuator and the burner capacity is therefore lowered. This ensures uniform temperature distribution even with a low heat output.

This function of the actuator IC 40 can also be used in the ceramics industry to correct the lambda value or for temperature compensation purposes in hot-air applications.

NOT UP TO DATE
www.dokument.com

Technical data

Mains voltage:

100–230 V AC, $\pm 10\%$, 50/60 Hz; the actuator automatically adjusts to the respective mains voltage.

Power consumption:

230 V AC: 12 W, 24 VA; 120 V AC: 10,5 W, 18 VA,

switch-on peak current: max. 8 A for max. 10 ms.

Screw terminals using the elevator principles for cables up to 4 mm² (single core cables) and for cables up to 2.5 mm² with wire end ferrules.

Angle of rotation: 0–90°.

Holding torque = torque as long as permanent supply voltage is applied.

2 digital inputs:

24 V DC or 100–230 V AC each.

Current requirement of digital inputs: 3 mA \pm 1.5 mA.

1 analogue input (optional): 4–20 mA

(internal load impedance: max. 500 Ω at 20 mA).

Potentiometer (optional):

1000 Ω \pm 20%,
linearity tolerance \pm 2%,
max. capacity 0.25 W,
conductive plastic element.

Important: tap wiper at high resistance.

2 digital outputs:

Signalling contacts designed as relay change-over contacts. Contact current of digital outputs: min. 5 mA (resistive) and max. 2 A.

The relay contacts can be connected to 100–230 V AC or 24 V DC. If the contacts have been connected with a voltage > 24 V and a current > 0.1 A once, the gold plating on the contacts will have been burnt through. This contact can then only be connected with this power rating or higher power rating.

2 LED status displays:

- Blue LED for operation "ON";
actuator in motion = slow flashing light;
manual operation = fast flashing light;
actuator stopped = permanent light.
- Red LED for warnings and faults;
warning = permanent light;
fault = flashing light.
- Red and blue LED simultaneously,
calibration in progress = flashing light.

Enclosure: IP 65.

Safety class: I.

Line entrance for electrical connection:
3 \times M20 plastic cable glands.

Ambient temperature: -20 to +60°C, no condensation permitted.

Storage temperature: -20 to +40°C.

Running times and torques

Type	Running time [s/90°]		Torque [Nm]	
	50 Hz	60 Hz	50 Hz	60 Hz
IC 40	4.5–76.5	4.5–76.5	2.5	2.5
IC 40S	4.5–76.5	4.5–76.5	3	3

On the IC 40, the running time and torque are independent of the mains frequency. The running time can be freely programmed between the limits of 4.5–76.5 s.

Type code

Code	Description
IC 40	Actuator
S	Safety closing function
A	Mains voltage: 100–230 V AC, 50/60 Hz
2	Torque: 2.5 Nm
3	3 Nm
A	4–20 mA analogue input
D	Digital inputs
R10	Feedback potentiometer

Maintenance cycles

Actuator IC 40 suffers little wear and requires little servicing.

We recommend a function check once a year.

If a service note has been activated in BCSoft, a warning signal is issued after

3 million cycles (0–90–0°/0–100–0%),
3 million relay switching operations,
5 million changes of direction.

NOT UP-TO-DATE
www.docuthek.com



Detailed information on this product



http://docuthek.kromschroeder.com/doclib/main.php?language=1&folderid=203060&by_class=6

Contact

www.kromschroeder.com → Sales

Elster GmbH
Postfach 2809 · 49018 Osnabrück
Strothweg 1 · 49504 Lotte (Büren)
Germany
T +49 541 1214-0
F +49 541 1214-370
info@kromschroeder.com
www.kromschroeder.com

We reserve the right to make technical modifications in the interests of progress.
Copyright © 2016 Elster GmbH
All rights reserved.