

**Operating instructions**  
**Gas pressure regulators VGBF**

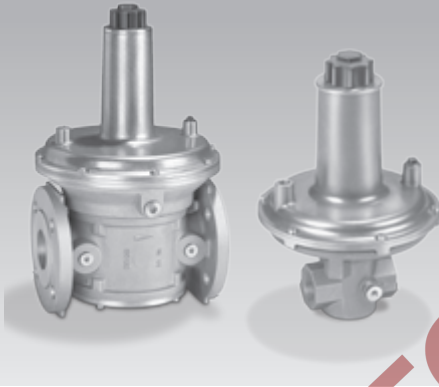

**Contents**

**Gas pressure regulators VGBF** ..... 1

**Contents** ..... 1

**Safety** ..... 1

**Checking the usage** ..... 2

Intended use ..... 2

Type code ..... 2

Part designations ..... 2

**Installation** ..... 2

**Installing the impulse line** ..... 3

**Tightness test** ..... 3

**Changing the outlet pressure  $p_d$**  ..... 4

**Checking the function** ..... 4

**Replacing the spring** ..... 4

**Maintenance** ..... 5

**Technical data** ..... 5

Designed lifetime ..... 5

**Logistics** ..... 5

**Certification** ..... 6

Declaration of conformity ..... 6

Eurasian Customs Union ..... 6

**Spring table** ..... 6

**Contact** ..... 6

**Safety**

**Please read and keep in a safe place**



Please read through these instructions carefully before installing or operating. Following the installation, pass the instructions on to the operator. This unit must be installed and commissioned in accordance with the regulations and standards in force. These instructions can also be found at www.docuthek.com.

**Explanation of symbols**

■, **1**, **2**, **3**... = Action

> = Instruction

**Liability**

We will not be held liable for damage resulting from non-observance of the instructions and non-compliant use.

**Safety instructions**

Information that is relevant for safety is indicated in the instructions as follows:

**⚠ DANGER**

Indicates potentially fatal situations.

**⚠ WARNING**

Indicates possible danger to life and limb.

**! CAUTION**

Indicates possible material damage.

All interventions may only be carried out by qualified gas technicians. Electrical interventions may only be carried out by qualified electricians.

**Conversion, spare parts**

All technical changes are prohibited. Only use OEM spare parts.

**Changes to edition 03.14**

The following chapters have been changed:

- Checking the usage
- Installation
- Tightness test
- Maintenance
- Certification

## Checking the usage

### Intended use

The gas pressure regulator VGBF serves to maintain a constant outlet pressure  $p_d$  despite changing gas flow rates and inlet pressures  $p_u$  in gas pipelines. This function is only guaranteed when used within the specified fields of application – see page 5 (Technical data).

Any other use is considered as non-compliant.

### Type code

Code	Description
<b>VGBF</b>	Gas pressure regulator
<b>15–150</b>	Nominal size
<b>R</b>	Rp internal thread
<b>F</b>	Flange to ISO 7005
<b>05</b>	$p_{u \text{ max.}}$ 500 mbar
<b>10</b>	$p_{u \text{ max.}}$ 1 bar
<b>40</b>	$p_{u \text{ max.}}$ 4 bar
<b>-1</b>	Screw plug at the inlet
<b>-3</b>	Screw plug at the inlet and outlet
<b>V</b>	Material for wetted parts: Viton (without approval) Medium: air and aggressive gases (check compatibility with Viton)

### Part designations

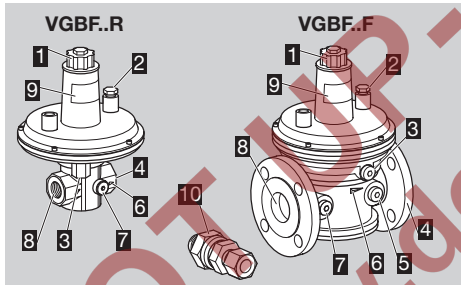

- 1** Cover cap and adjusting screw
- 2** Breather screw
- 3** Impulse line connection (not on VGBF..05)
- 4** Outlet
- 5** Outlet ( $p_d$ ) measuring connection
- 6** Arrow of direction of flow
- 7** Inlet ( $p_u$ ) measuring connection
- 8** Inlet
- 9** Type label
- 10** Damping valve for VGBF 40–100..40

Inlet pressure  $p_u$ , outlet pressure  $p_d$  and ambient temperature: see type label.

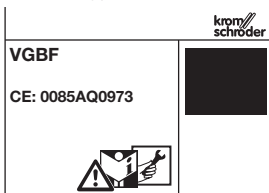

## Installation

### ! CAUTION

Please observe the following to ensure that the gas pressure regulator is not damaged during the installation:

- Install the unit free of mechanical stress.
- Do not clamp the unit in a vice or use it as a lever. Risk of external leakage.
- Sealing material, cuttings and other impurities must not be allowed to get into the regulator housing.
- The installation location must be dry. Do not store or install the unit in the open air.
- Dropping the device can cause permanent damage. In this event, replace the entire device and associated modules before use.
- Installation in the horizontal position, never upside down. VGBF 15 – 50 can also be installed in the vertical position.

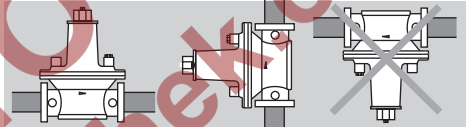

- ▷ The outlet pressure  $p_d$  is set at the factory with the spring dome pointing vertically upwards. VGBF 15 – 50: if installed with the spring dome in the horizontal position, check and adjust the outlet pressure  $p_d$ , see page 4 (Changing the outlet pressure  $p_d$ ).
- ▷ The housing must not touch any surrounding walls. Minimum clearance 20 mm. Ensure that there is sufficient space for installation and adjustment.
- 1** Install a filter upstream of the unit, in order to protect it against impurities in the pipeline.

### VGBF..F

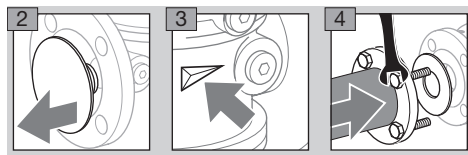

### VGBF..R

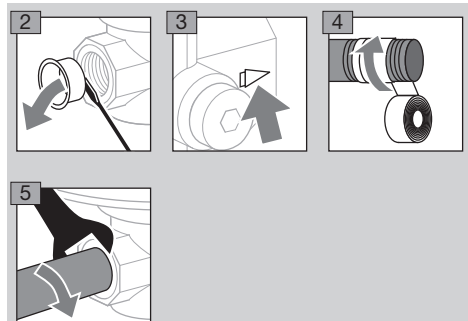

## Installing the impulse line

### VGBF 40–150..05 for 500 mbar

- ▷ No external impulse line required. VGBF..05 features an internal feedback function.

### VGBF 40–100..40 for 4 bar

- ▷ In order to avoid possible oscillations, a damping valve should be fitted. The damping valve is secured to the spring dome with an adhesive strip on delivery.
- ▷ Impulse line: 12 × 1.5 mm.

### VGBF 40–100

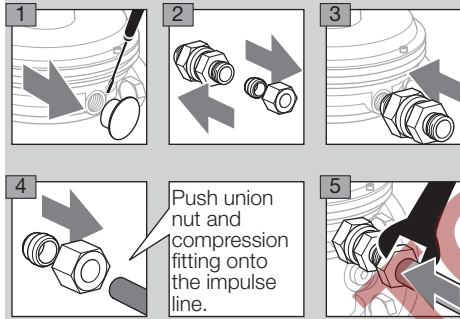

### VGBF 15–100..10 for 1 bar and VGBF 15–100..40 for 4 bar

- 6 Install the impulse line and seal with an approved sealing material.

### VGBF 15–25R

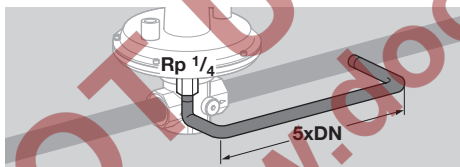

### VGBF 40–150

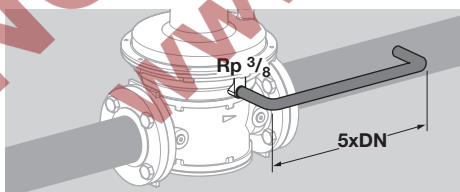

## Tightness test

### ⚠ WARNING

If gas-filled spaces have been opened, check them for tightness.

- 1 Block the pipeline at the inlet and outlet.
- 2 Slowly apply inlet pressure  $p_u$ .  
( $p_u \leq 1.5 \times p_{u \max}$ , see type label)
- 3 Slowly apply outlet pressure  $p_d$ .  
( $p_d \leq 1.5 \times p_{d1}$ , see type table)

## ! CAUTION

- First apply the inlet pressure  $p_u$ —then the outlet pressure  $p_d$ .
- The inlet pressure  $p_u$  must always be equal to or higher than the outlet pressure  $p_d$ .
- In the event of non-compliance with the sequence, the inlet pressure compensation diaphragm will reverse.

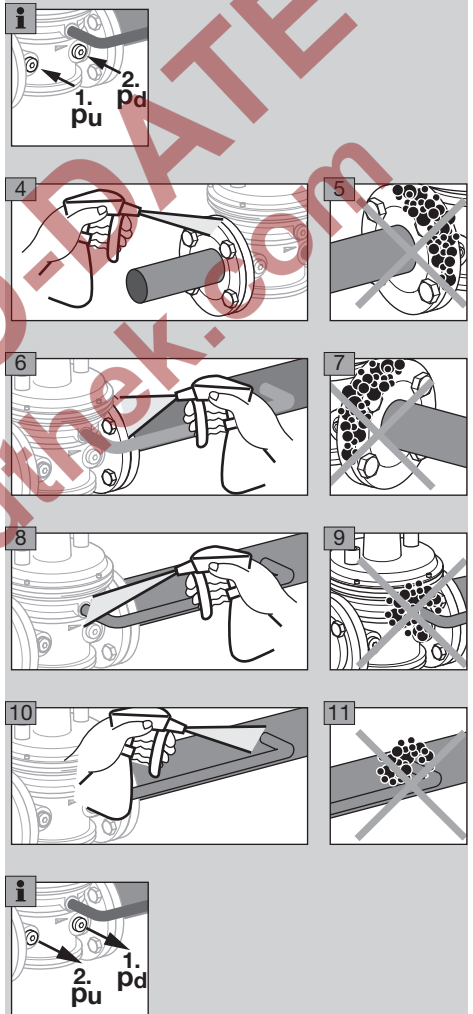

- 12 Relieve the outlet pressure  $p_d$ .
- 13 Relieve the inlet pressure  $p_u$ .

## Changing the outlet pressure $p_d$

- ▷ The outlet pressure  $p_d$  is set at the factory with the spring dome pointing vertically upwards. If the VGBF is installed with the spring dome in the horizontal position, check and adjust the outlet pressure  $p_d$ .
- ▷ Use the test points on the unit only for measurements of zero flow or very slight flow.

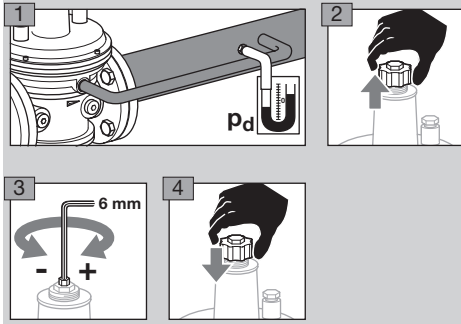

- 5 Clearly mark the adjusted value of the outlet pressure  $p_d$  on the type label.

## Checking the function

- 1 Request different outputs on the burner in order to change the flow rate.
- 2 Close the manual valve at the inlet a little in order to change the inlet pressure  $p_u$ .
  - ▷ Despite changing flow rates and inlet pressures  $p_u$  (within the capacity range of the VGBF), the outlet pressure  $p_d$  must remain constant ( $\pm 10 - 15\%$ ).
- 3 Reduce the capacity to low-fire rate and close the valve downstream of the VGBF.
  - ▷ Approx. 30 seconds after the valve has been closed, the outlet pressure  $p_d$  should not increase significantly.

Check the tightness of the VGBF during operation to detect possible leaks due to hardened rubber materials.

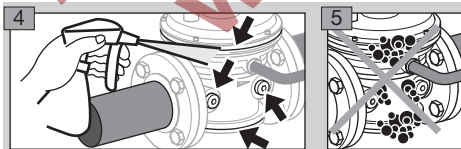

- 6 If a leak is found, replace the rubber materials.
  - ▷ Selecting spare parts: see [www.adlatus.org](http://www.adlatus.org), Part Detective.
- 7 Then check for tightness once again.

## Replacing the spring

- 1 Choose a spring according to the outlet pressure range (see page 6 (Spring table)).
- 2 Remove the cover cap.

## ⚠ WARNING

Risk of injury!

- The taut spring can pop out when opening the spring dome. Therefore, decompress the spring as far as it will go before opening. Then turn back 5 x to relax the spring counter bearing.

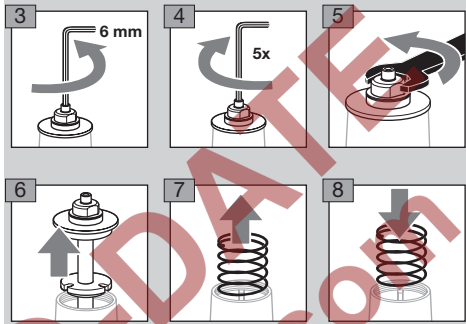

### VGBF 15–50

- 9 Turn down the spring counter bearing slightly.

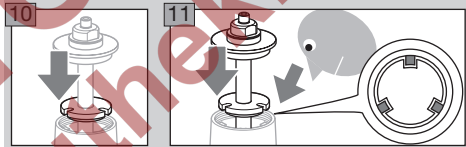

- 12 Ensure that the guide grooves and bars engage in each other.

### VGBF 65–150

- 9 Turn down the spring counter bearing slightly.

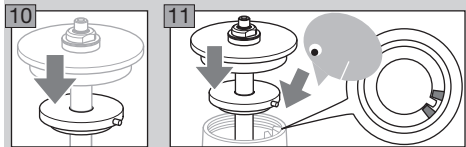

- 12 Ensure that the guide groove and the cylinder engage in each other.

### VGBF 15–150

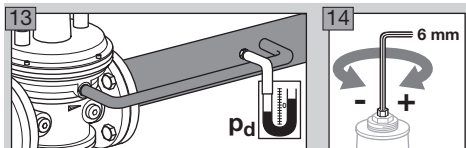

- 15 Screw on cover cap.
- 16 After inserting the spring, take the spring's label from the packaging and stick it below the type label on the pressure regulator.
- 17 Clearly mark the adjusted value of the outlet pressure  $p_d$  on the type label.

## Maintenance

In order to ensure smooth operation, check the tightness and function of the gas pressure regulator every year, or every six months if operated with biogas, see page 4 (Checking the function) and page 3 (Tightness test).

- ▷ Spare parts, see [www.adlatus.org](http://www.adlatus.org), PartDetective.
- ▷ If gas-filled space has been opened, check the tightness and function, see page 3 (Tightness test) and page 4 (Checking the function).

## Technical data

Gas type: natural gas, town gas, LPG (gaseous) and biogas, VGBF..V for air.

Outlet pressure ranges:

The outlet pressure range is achieved through the use of different springs (see page 6 (Spring table)).

Rp 1/4 connection for test points or even for a pilot gas line:

at the inlet: VGBF 15 and 25,

at inlet and outlet: VGBF 40–150.

Ambient temperature: -15 to +60°C,

VGBF..V: 0 to 60°C.

No condensation permitted.

Long-term use in the upper ambient temperature range accelerates the ageing of the elastomer materials and reduces the service life (please contact manufacturer).

Storage temperature: -15 to +40°C,

VGBF..V: 0 to 40°C.

Strainers that are possibly fitted serve as flow conditioners.

Housing: aluminium,

diaphragms: NBR or Viton,

valve seat: aluminium,

valve stem: aluminium,

valve disc: vulcanized NBR or Viton seal.

Internal thread: Rp to ISO 7-1,

flanged connection: PN 16 to ISO 7005,

DN 15–50 with NPT thread,

DN 50–100 available with ANSI flange.

Impulse line connections: NPT.

Weight [kg]:

Type	Weight	Type	Weight
VGBF 15R	0.9	VGBF 65F	12.0
VGBF 25R	1.9	VGBF 80F	16.1
VGBF 40R	2.9	VGBF 100F	26.0
VGBF 40F	4.8	VGBF 150F	46.5
VGBF 50F	7.7		

### VGBF..10

Max. inlet pressure  $p_{U \max.}$ : 1 bar.

Feedback via impulse line:

Rp 1/4 connection for DN 15 and 25,

Rp 3/8 connection for DN 40 – 150.

EN 334, Accuracy Class AC 10, Lock up pressure class SG 30.

### VGBF..40

Max. inlet pressure  $p_{U \max.}$ : 4 bar.

Feedback via impulse line:

Rp 1/4 connection for DN 15 and 25,

Rp 3/8 connection for DN 40 – 100.

EN 334, Accuracy Class AC 10, Lock up pressure class SG 30.

### VGBF..05

Max. inlet pressure  $p_{U \max.}$ : 500 mbar.

Internal feedback.

EN 88, Class A, Group 2.

### Designed lifetime

This information on the designed lifetime is based on using the product in accordance with these operating instructions. Once the designed lifetime has been reached, safety-relevant products must be replaced. Designed lifetime (based on date of manufacture) in accordance with EN 13611 and EN 88 for VGBF: 15 years.

You can find further explanations in the applicable rules and regulations and on the [afecor](http://www.afecor.org) website ([www.afecor.org](http://www.afecor.org)).

This procedure applies to heating systems. For thermoprocessing equipment, observe local regulations.

## Logistics

### Transport

Protect the unit from external forces (blows, shocks, vibration). On receipt of the product, check that the delivery is complete (see page 2 (Part designations)). Report any transport damage immediately.

### Storage

Store the product in a dry and clean place.

Storage temperature: see page 5 (Technical data).

Storage time: max. 6 months before using for the first time.

### Packaging

The packaging material is to be disposed of in accordance with local regulations.

### Disposal

Components are to be disposed of separately in accordance with local regulations.

## Certification

### Declaration of conformity

We, the manufacturer, hereby declare that the product VGBF with product ID No. CE-0085AQ0973 complies with the requirements of the listed Directives and Standards.

VGBF 15 to VGBF 150:

Directive:

– 2009/142/EC – GAD (valid until 20 April 2018)

Regulation:

– (EU) 2016/426 – GAR (valid from 21 April 2018)

Standards:

– DIN EN 88-1:2011

– DIN EN 88-2:2008

– DIN EN 334:2009

VGBF 100F40:

Directive:

– 97/23/EC

The relevant product corresponds to the tested type sample. The production is subject to the surveil-

lance procedure pursuant to Directive 2009/142/EC Annex II paragraph 3 (valid until 20 April 2018) and to Regulation (EU) 2016/426 Annex III paragraph 3 (valid from 21 April 2018) and for VGBF 100F40 according to annex III, module D1 of Directive 97/23/EC. This declaration of conformity is issued under the sole responsibility of the manufacturer.

Elster GmbH

Scan of the Declaration of conformity (D, GB) – see [www.docuthek.com](http://www.docuthek.com)

### Eurasian Customs Union



The product VGBF meets the technical specifications of the Eurasian Customs Union.

## Spring table

Outlet pressure	Order No.				Marking
$p_d$ [mbar]	VGBF 15	VGBF 25	VGBF 40	VGBF 50	
5–12.5	75421911	75421961	75421961	75422031	–
10–30**	75421921	75421971	75421971	75422041	red
25–45	75421931	75421980	75421980	75422051	yellow
40–60	75421941	75421990	75421990	75422061	green
55–75	75421951	75422000	75422000	75422071	blue
70–90	75442046	75422010	75422010	75422081	black
85–105	75442047	75422020	75422020	75422091	white
100–160	75442048	75438978	75438978	75438981	black/red
150–230	75442049	75438979	75438979	75438982	black/yellow
220–350	75442050	75438980	75438980	75438983*	black/green

Outlet pressure	Order No.				Marking
$p_d$ [mbar]	VGBF 65	VGBF 80	VGBF 100	VGBF 150	
5–12.5	75426160	75426230	75426310	75426450	–
10–30**	75426170	75426240	75426320	75426460	red
25–45	75426180	75426250	75426330	75426470	yellow
40–60	75426190	75426260	75426340	75426480	green
55–75	75426200	75426270	75426350	75426490	blue
70–90	75426210	75426280	75426360	75426500	black
85–105	75426220	75426290	75426370	75426510	white
100–160	75446329	75438984	75438987	75438990	black/red
150–230	–	75438985	75438988	–	black/yellow
220–350	–	75428986	75438989	–	black/green

\* Spring set comprising two springs.

\*\* Standard spring

Mark the new outlet pressure on the type label–adhesive label supplied.

## Contact

If you have any technical questions, please contact your local branch office/agent. The addresses are available on the Internet or from Elster GmbH.

We reserve the right to make technical modifications in the interests of progress.

# Honeywell

**krom  
schroder**

Elster GmbH  
Strotheweg 1, D-49504 Lotte (Büren)  
Tel. +49 541 1214-0

Fax +49 541 1214-370

[hts.lotte@honeywell.com](mailto:hts.lotte@honeywell.com), [www.kromschroeder.com](http://www.kromschroeder.com)