

Increased efficiency for drying,
firing and glazing

Heat treatment in the ceramics industry

Edition 03.18 GB

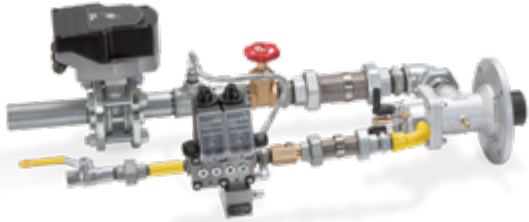

Ceramics Industry

We control your kilns and your success!

Honeywell Kromschöder products for industrial heat treatment processes combine energy efficiency, maximum safety and availability as well as an optimum price/performance ratio resulting in tailor-made solutions for the ceramics industry.

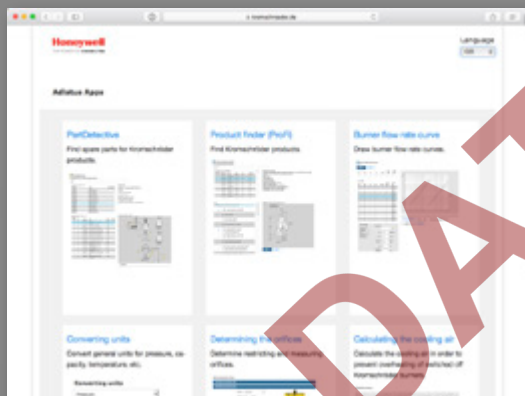

Find products and spare parts, draw burner flow rate curves, calculate orifices and burner lengths and other useful web-apps at www.adlatus.org.

NOT UP-TO-DATE
www.docuthek.com

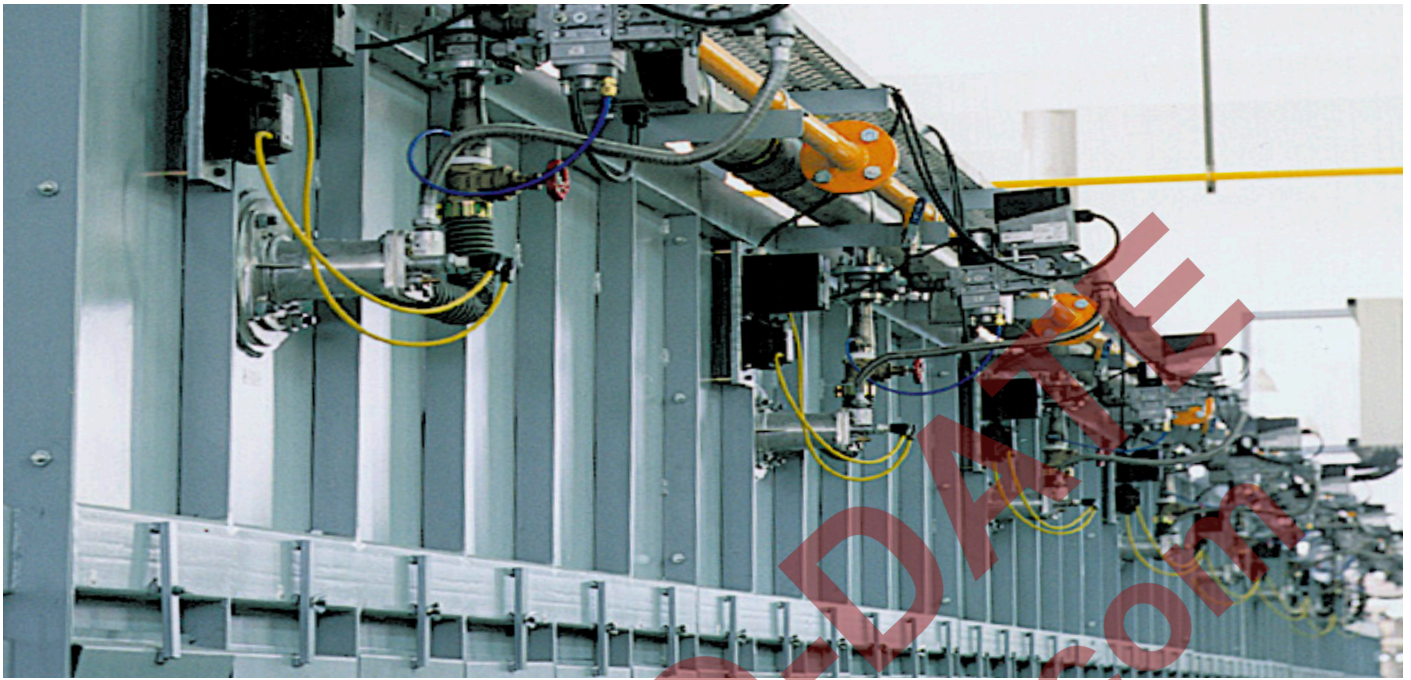

Roller hearth kiln,
works photograph Dum-Kilnogy S.A.

What counts in a competitive world are the facts!

Our product range for firing technology has a modular structure. Thanks to this modular system, you will benefit from functional and logistical advantages as well as cost benefits.

Honeywell Kromschröder systems are a key cost-cutting factor because they are easy to assemble and install. Commissioning procedures are accordingly short and straightforward. We also offer a special range of courses for various customer and product groups, should you require extra support. Our competent Service Team is also there to help.

Safety first. Honeywell Kromschröder gas safety and control systems comply with the requirements of standards and regulations in order to provide your operating personnel with optimum protection. This also applies for the current requirements to SIL/PL.

High system availability is the prerequisite for cost-effective operation. The design and robust construction of the Honeywell Kromschröder firing systems ensure a long service life.



Overhead firing with BIC burners



You can access comprehensive technical information, operating manuals, animations and price lists, etc. in our document library at www.docuthek.com.

When modernizing or expanding existing systems, the modular design of our product range proves to be of decisive advantage since it means that individual system components can be easily retrofitted or replaced.

Preventive maintenance is a prerequisite for perfect operation, high availability and economy. For this reason, our Service Team can offer you individually tailored maintenance contracts.

We are making our contribution to environmental protection with resource saving production and a high degree of reusability of every component.

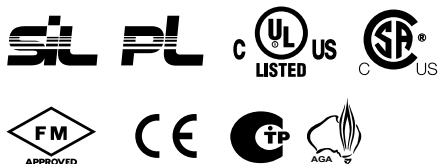

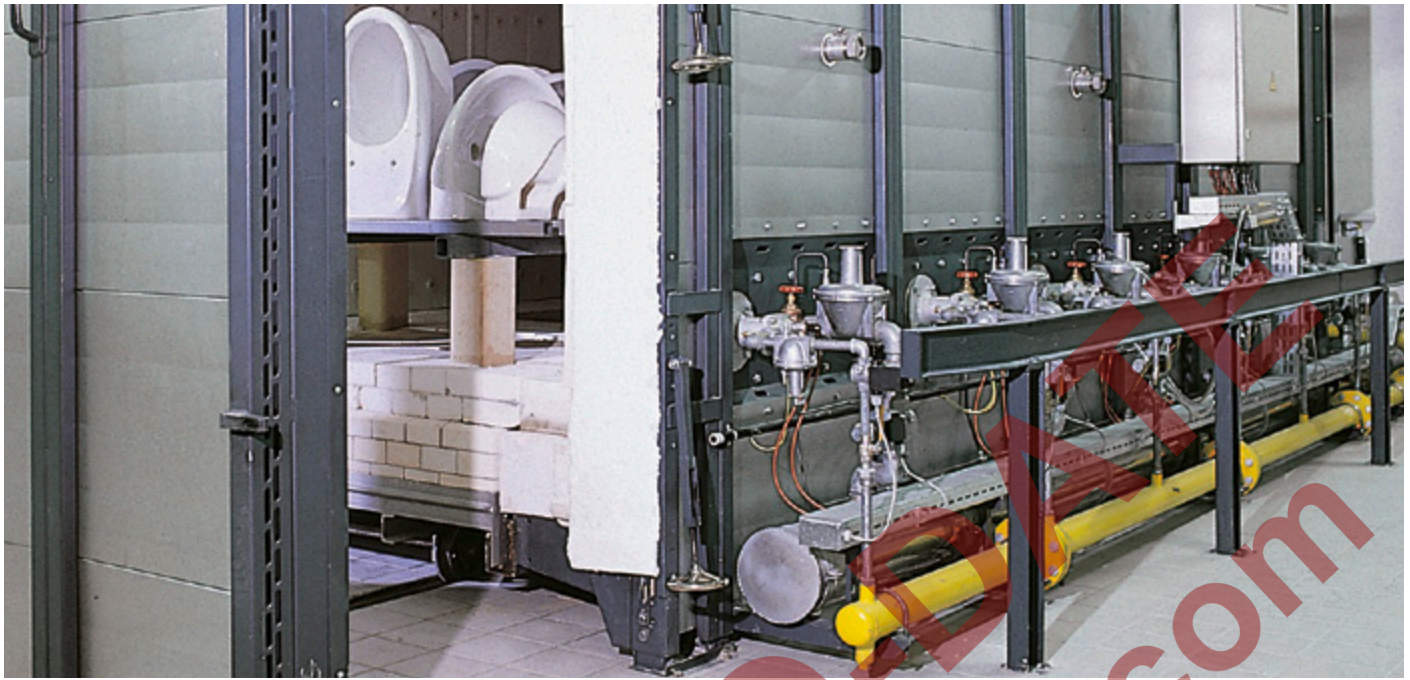

*Intermittent shuttle kiln,
works photograph Eisenmann*

We are prepared for any questions our customers may have and always have a solution at the ready.

Does your production process require homogeneous temperature distribution throughout the kiln chamber?

Then Honeywell Kromschöder impulse burners are the best solution. The top-quality high-speed burners ensure optimum mixing of gas and air.

Are you aiming for a low-pollution and environmentally-friendly production process?

Honeywell Kromschöder reduction systems allow low-pollutant production with uniform colour range without the additional use of coal and minerals.

Would you like to be able to use the gas type of your choice?

All Honeywell Kromschöder systems are suitable for town gas, natural gas and LPG. In addition, we can supply a large assortment of reliable gas controls and burners for sewage gas, landfill gas, biologically produced methane, generator gas and coal gas.

Are you concerned about not wasting energy?

The heat in the flue gas can be supplied to the burner by directing it through heat exchangers in order to raise the temperature of the combustion air. Honeywell Kromschöder can provide the necessary control valves for gas and air.

Do you want to make use of every opportunity to increase efficiency?

Burners with integrated recuperator from Honeywell Kromschöder allow an energy saving of up to 30% due to air preheating up to 700°C. They are used for direct heating or in conjunction with single-ended radiant tubes for indirect heating of kiln systems.

Do you have fixed ideas about flexibility?

Honeywell Kromschöder always proves to be a competent partner in individual solutions – be it for continuous lambda correction or switchable oxidation/reduction cycles in a burner control system.

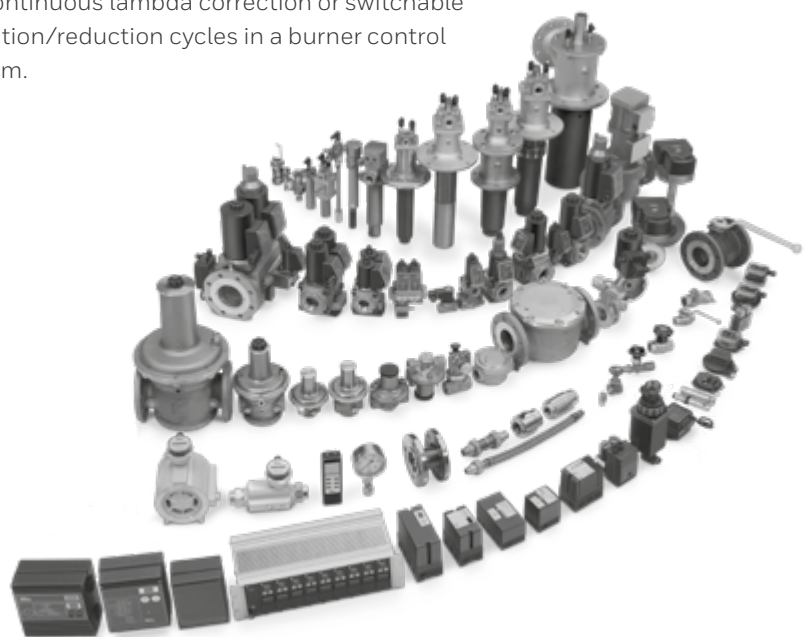





EISENMANN

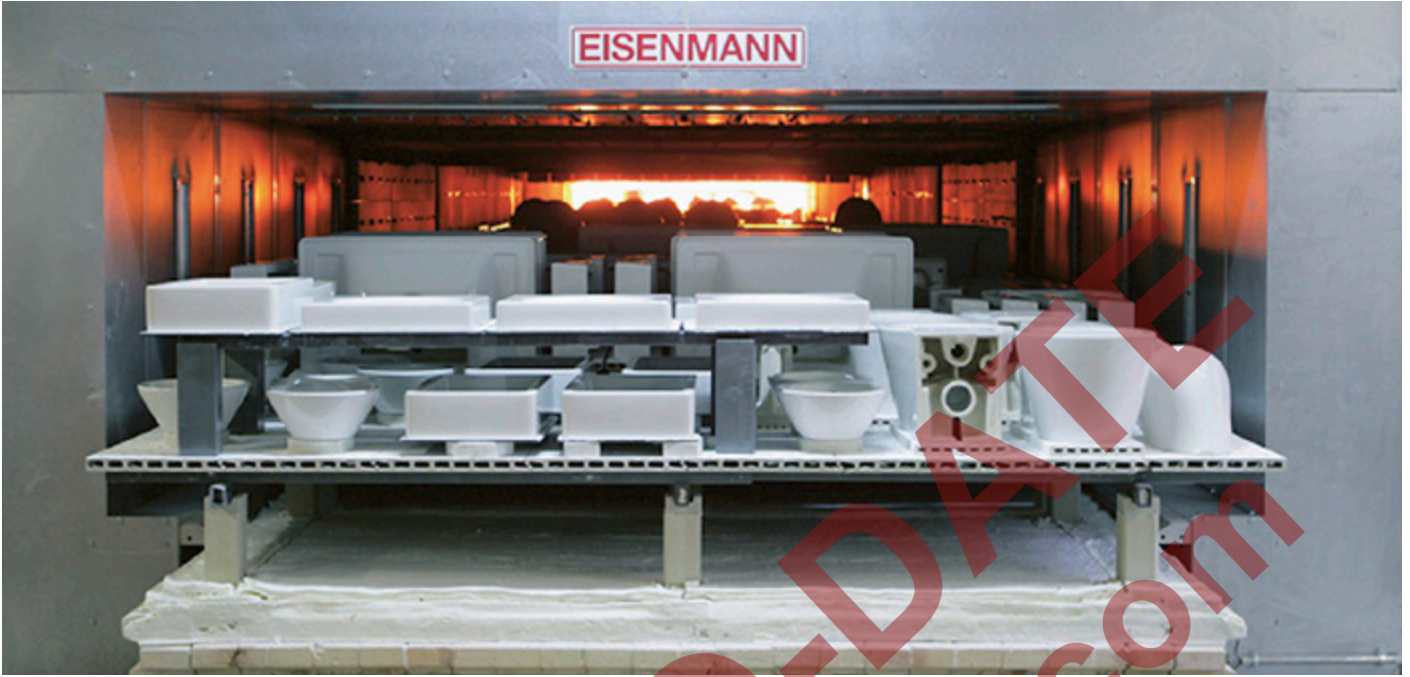

Intermittent shuttle kiln,
works photograph Eisenmann

Gas pressure control and safety line as a system solution

We provide complete solutions with pre-assembled gas safety, measurement and control systems to EN 746-2 for the gas distribution system on industrial thermoprocessing installations with downstream burner systems. Here, all the individual components are perfectly coordinated. The solutions are designed to strictly comply with current standards and regulations.

The protective system control FCU 500 monitors and controls the central safety functions of Gas-min, Gasmax, Airmin, pre-purge, tightness test, high temperature operation or start enable for burner control units in multiple burner systems.

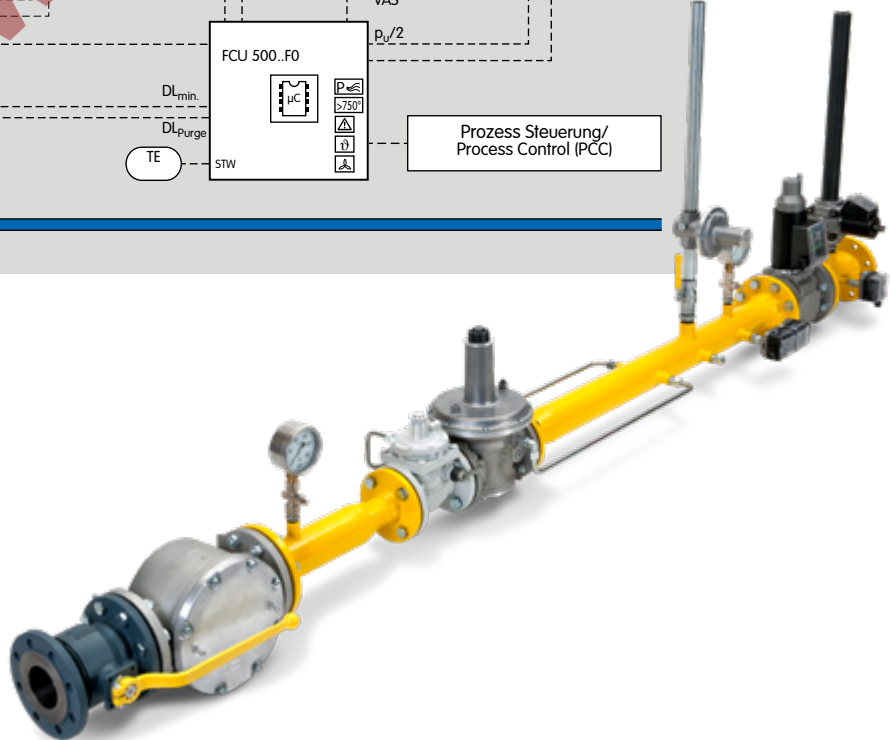
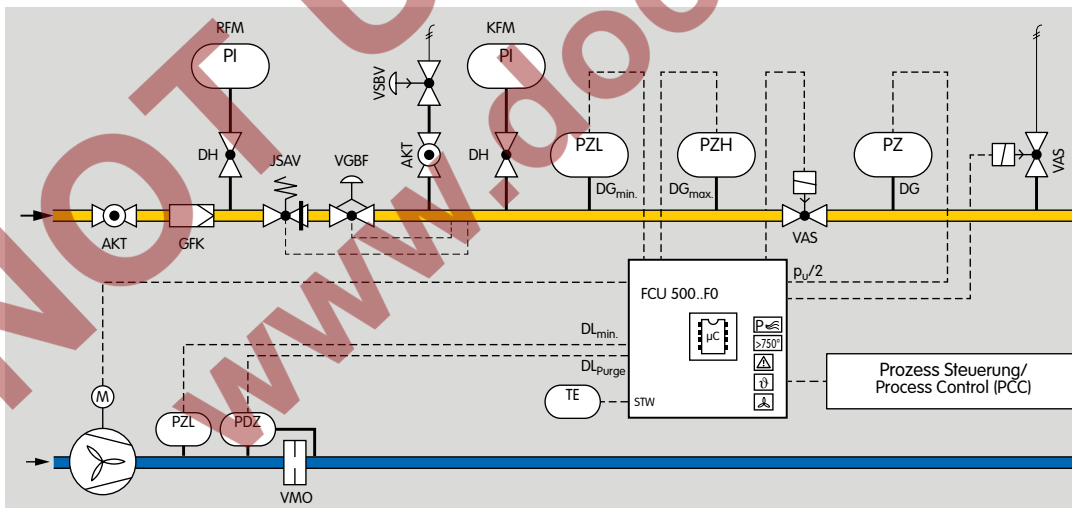



Tunnel kiln,
works photograph Riedhammer

Stage-controlled heating system with cold air and pneumatic ratio control system

Staged control with rotary impulse control is an optimal solution for systems requiring a large control range. In the case of cyclical control, the burners are switched on and off or are controlled in High/Low mode. The capacity supplied to the process is controlled by means of a variable ratio of the operating time to the pause time. In this type of control, the burner output pulse frequency always maintains full momentum and maximum convection is obtained in the kiln chamber, even with low capacity supply.

This ensures uniform temperatures in the kiln. Automatic burner control units with air valve control allow pre-purge as well as cooling via the burners which is controlled by the impulse system.

Two valve outputs on the automatic burner control unit for separate activation of the bypass valve and main valve ensure the fail-safe limitation of the start fuel flow rate in accordance with EN 746-2. The air supply can also be controlled in two stages using smart air control valves so that a defined air/gas ratio prevails in the burner in all operating states.

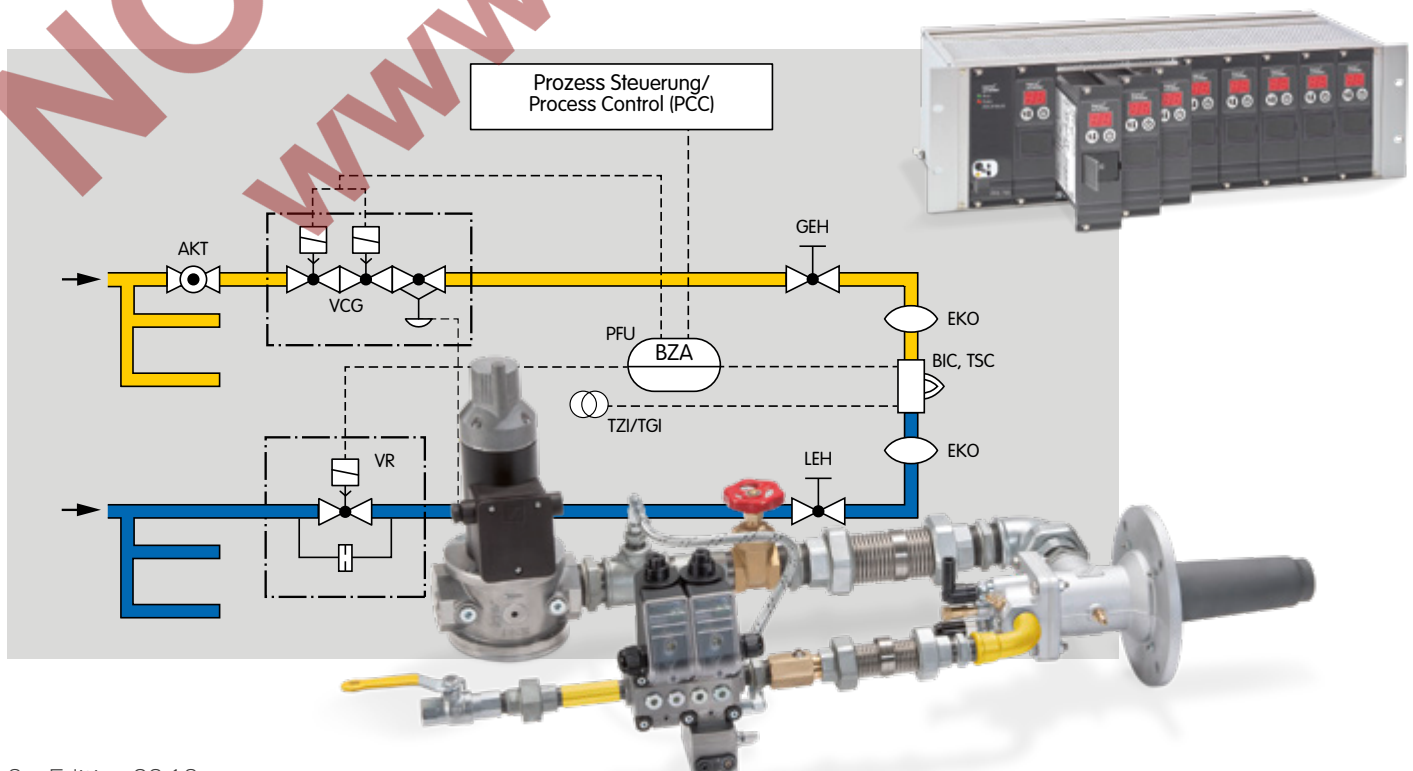





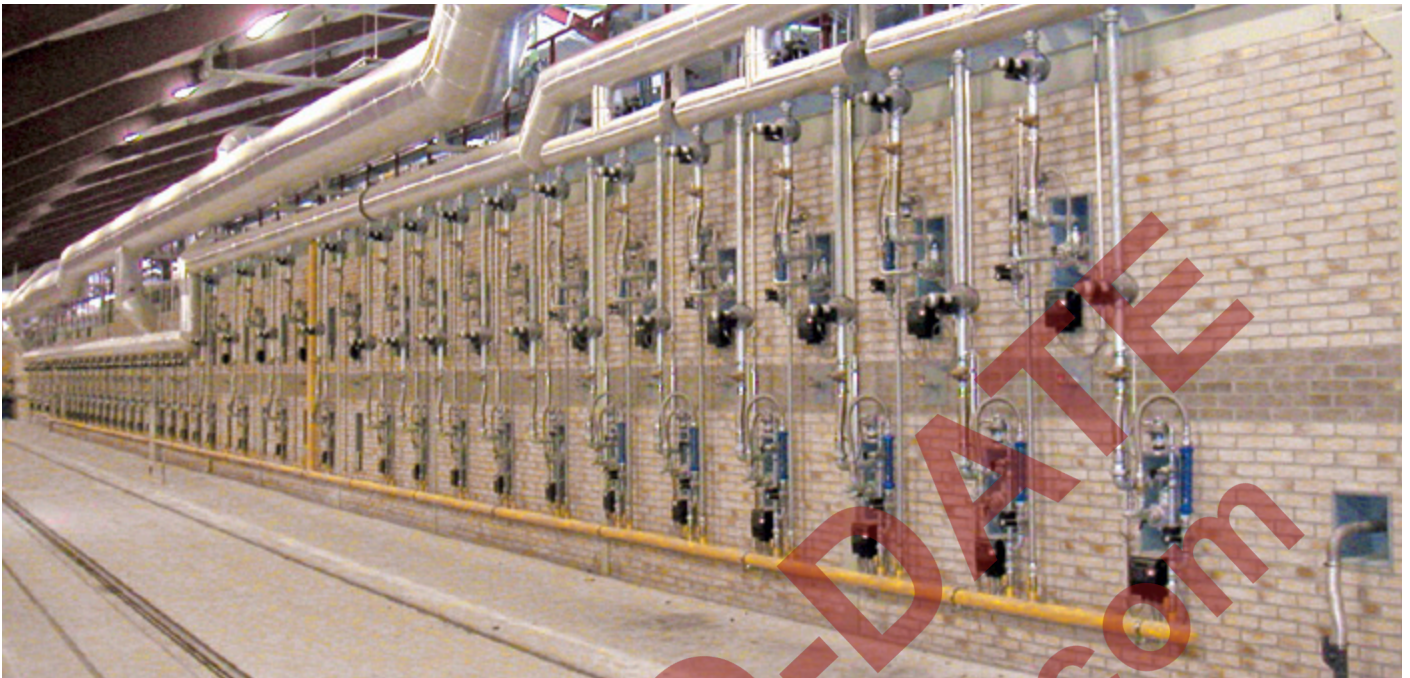

Tunnel kiln,
works photograph Keller H,C,W

Continuously controlled heating system with cold air and pneumatic ratio control system

Modulating control is a cost-effective option for controlling processes. The capacity can be adjusted continuously by activating the air control valve (analogue or 3-point step signal). The pneumatic ratio control system controls the gas pressure proportionally to the air pressure and thus maintains a constant gas/air ratio. At the same time, it acts as an air deficiency cut-out.

Adjusting valves and/or butterfly valves are used for limiting the air and gas volumes and for adjusting the gas/air ratio.

Kiln pressure fluctuations have the same effect on the gas and air throughput so that the gas/air ratio will remain unchanged. Ignition and monitoring are ensured by an automatic burner control unit which is approved for continuous operation if the burner is to operate for more than 24 hours, in accordance with EN 746-2.

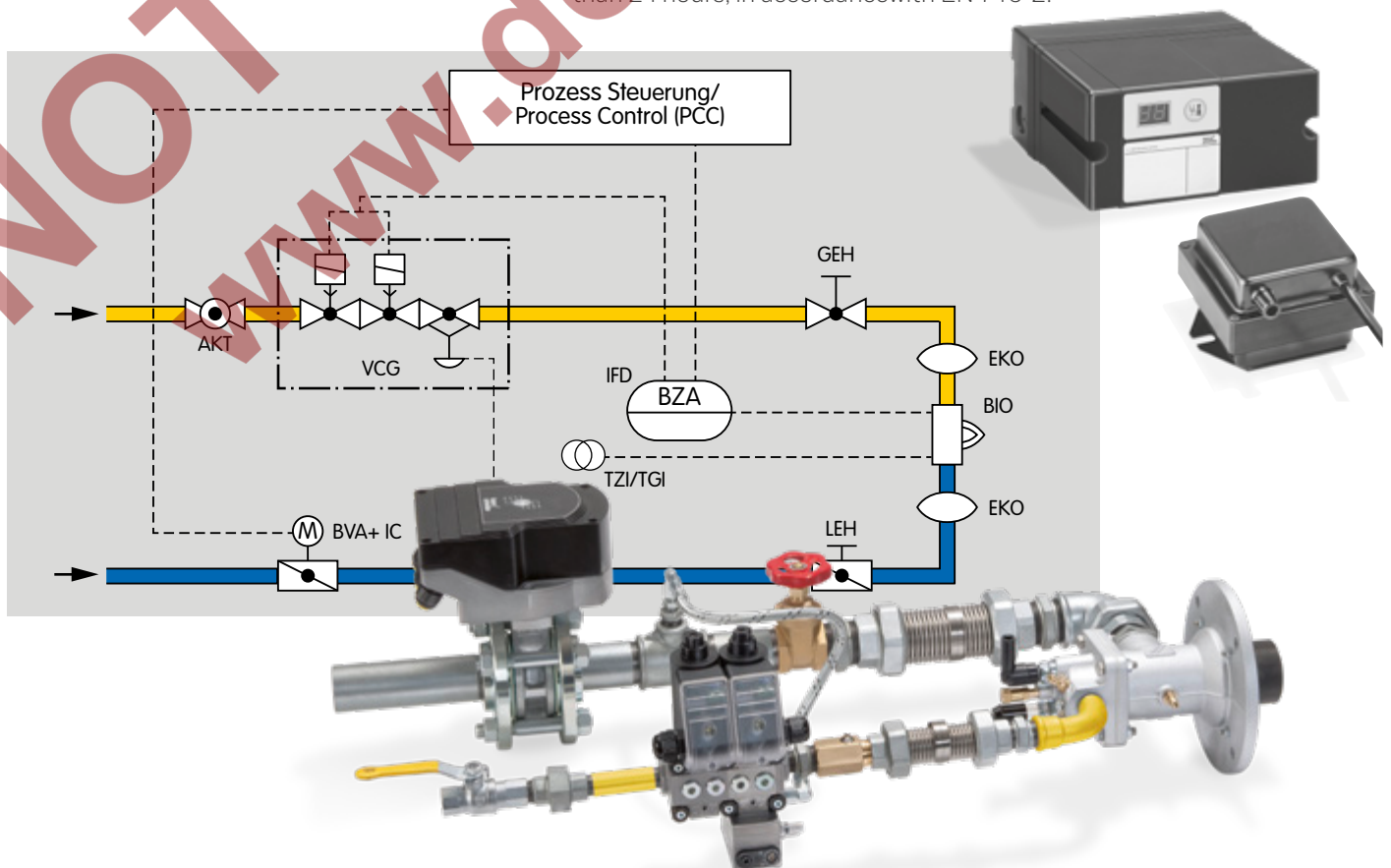



*Roller hearth kiln,
works photograph Keramischer OFENBAU GmbH*

Continuously controlled heating system with additional secondary air

Continuously controlled heating systems with additional secondary air are particularly suitable for use in high-speed kilns. Two air connections allow a very high lambda value of up to $\lambda = 50$ to be reached. The flame outlet temperature can be adjusted directly to the kiln temperature/time profile in intermittent systems with minimum energy supply while also supplying a high flame outlet velocity and therefore high convective heat transfer.

The separate secondary air supply ensures CO-optimized combustion with high excess air. The large air cross-sections enable large volumes of air to be introduced during the system's cooling phase.

This leads to a reduction in the cooling time and therefore to an increase in the system's availability. Reducing and oxidizing combustion are possible. Ignition and monitoring are ensured by an automatic burner control unit which is approved for continuous operation if the burner is to operate for more than 24 hours, in accordance with EN 746-2.

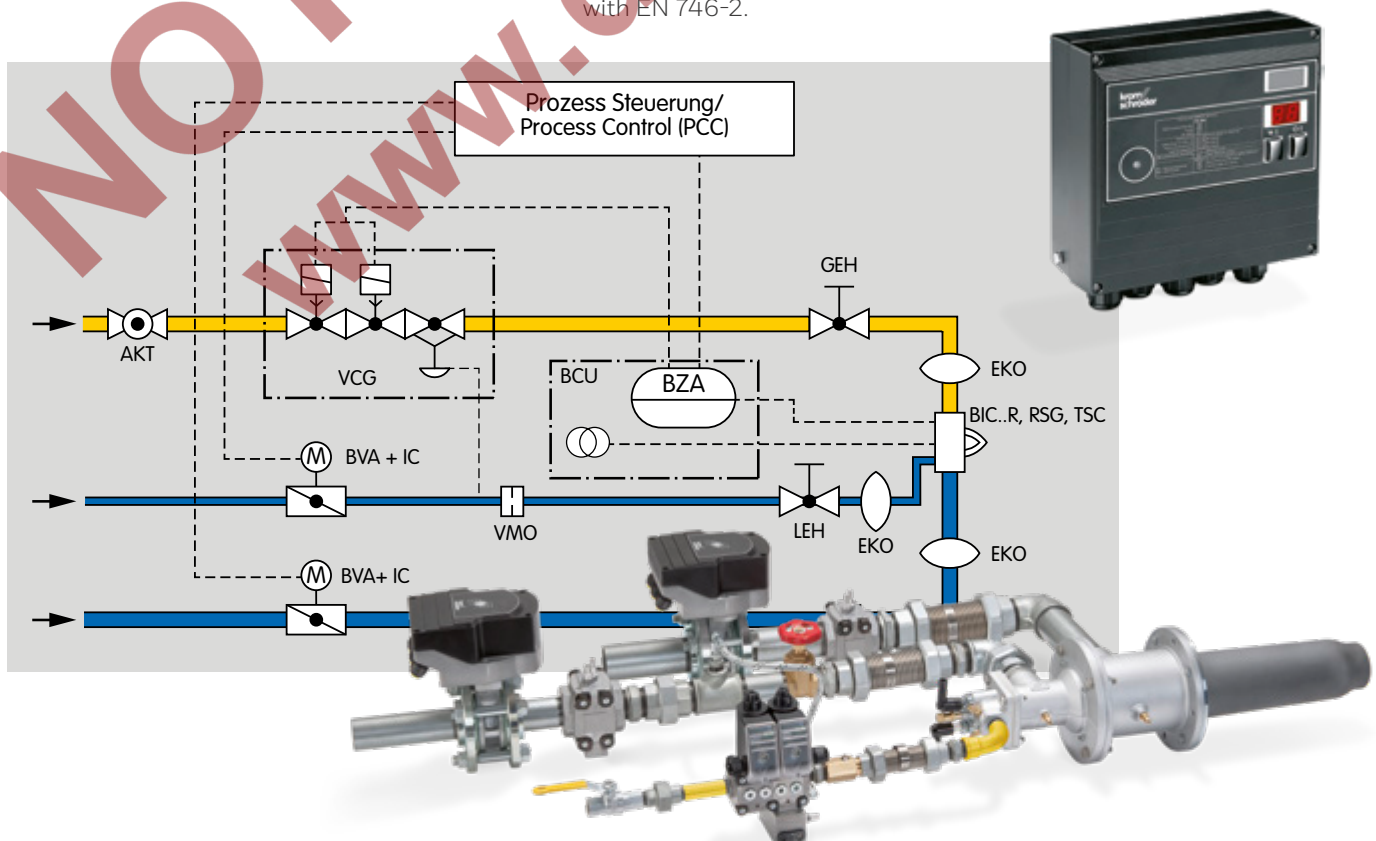



NOT UP-TO-DATE
www.docuthek.com



NOT UP-TO-DATE
www.docuthek.com

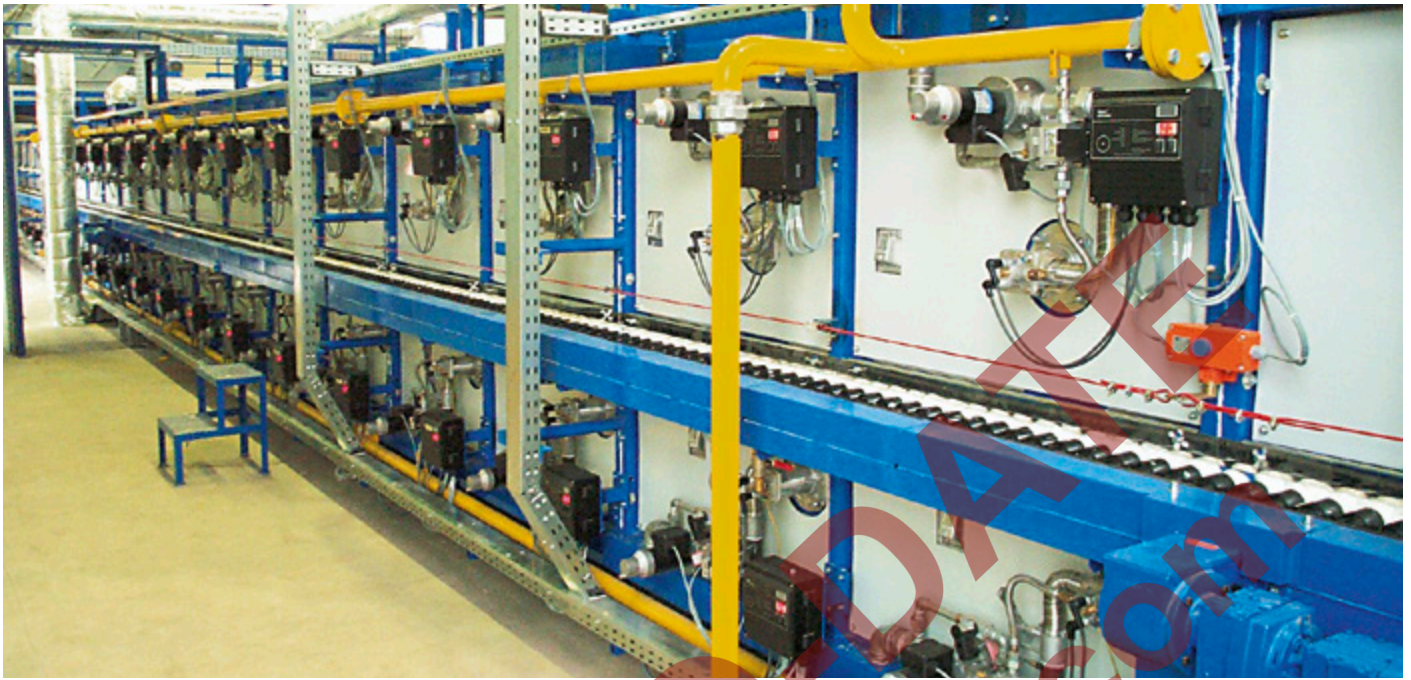

Roller hearth kiln,
works photograph Laeis Bucher

Continuous control with zoned air control

Intermittent shuttle kilns and tunnel kilns equipped with this control system are a tried-and-tested, low-cost solution for heavy-clay and fine ceramics production. Continuous control combined with hot air is used to reach very high temperatures (e.g. for engineering ceramics).

Continuous control with a pneumatic air/gas ratio control system offers the advantage of a constant lambda value over a wide control range with simultaneous air deficiency cut-out. Continuous control of the gas flow rate with a constant air flow rate allows the capacity to be

adjusted while maintaining an almost constant outlet velocity at the burner.

The protective system control FCU takes over control of the butterfly valves. The zone FCUs are informed by the safety interlock input that the central FCU has issued the enable signal for the burners. Ignition and monitoring are ensured by an automatic burner control unit which is approved for continuous operation if the burner is to operate for more than 24 hours, in accordance with EN 746-2.

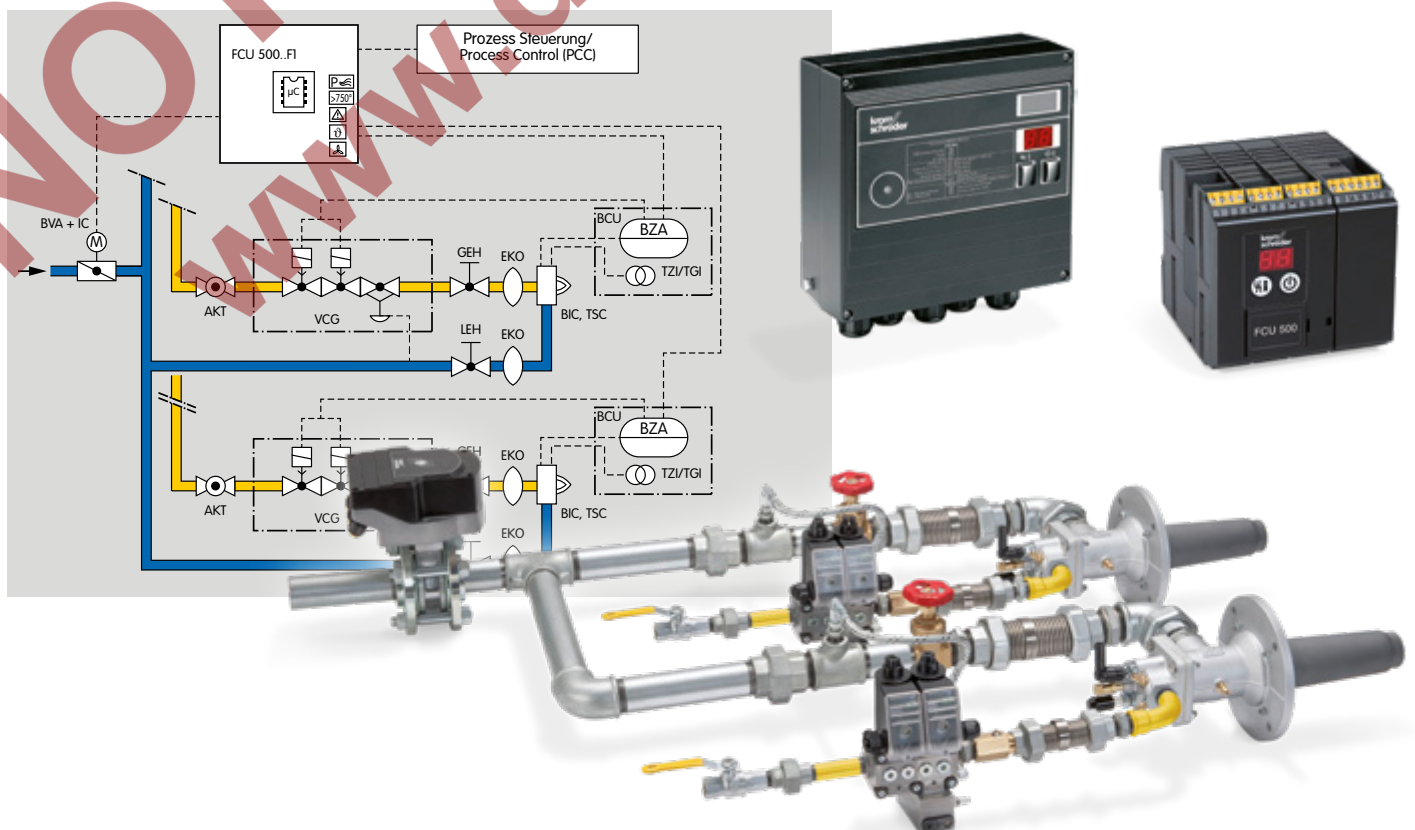



Intermittent shuttle kiln, works photograph Nabertherm

Extremely safe: SIL and PL at Honeywell Kromschroder

Uncompromising safety and all-round functionality are key features of Honeywell Kromschroder's high quality components and system solutions. Not to mention their compact, resource-saving design. For us this is a very important aspect of product quality. Our 'lean design' concepts will save you money.

Thermoprocessing equipment must comply with high levels of safety and reliability so that the lowest possible risk levels are generated for people, the environment, products and processes in the event of a malfunction. Probability-based approaches to risk assessment and prevention are now becoming increasingly popular in this area of application – such as Safety Integrity Level (SIL) and Performance Level (PL) classification. Comprehensive risk analyses, which are the best possible way of identifying any potential risks, are at the heart of these considerations. The precisely harmonized measures of the individual safety functions for minimizing risks are then based on these.



Honeywell Kromschroder can provide interested companies with targeted and competent support when redesigning safety functions pursuant to SIL and PL Standards. Your contacts are the specialists in the individual branch offices who develop individual and system-specific solutions together with the respective customers. Further information on SIL and PL is also available at www.k-sil.de







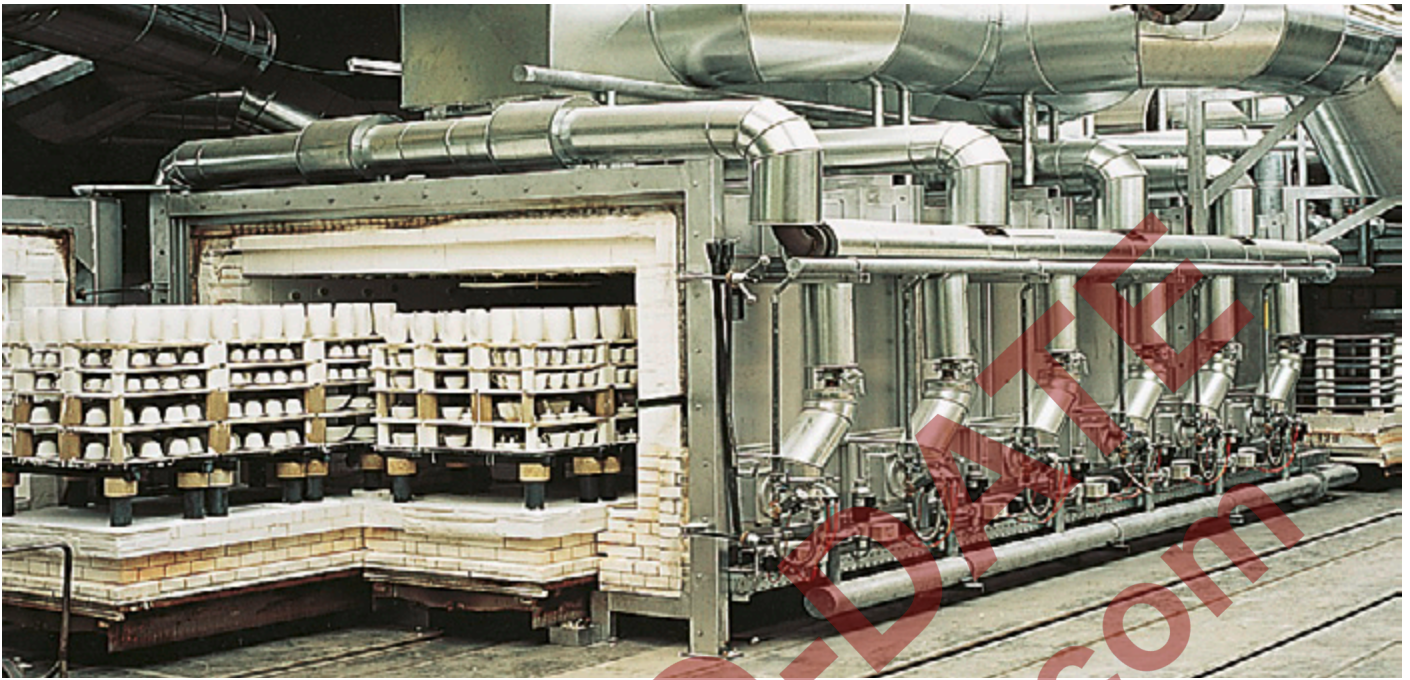

Roller hearth kiln,
works photograph Riedhammer

Honeywell Kromschroder presents the Internet-based KST knowledge platform

Comprehensive system knowledge is particularly valuable for planners and operators of thermoprocessing equipment. Their requirements stretch from knowledge of the physical interrelations, through compliance with legal documents such as national and international Directives and Standards, to experience of different devices and fittings and the way they interact within a system. The new "Kromschroder System Technology" (KST) knowledge platform continues to offer support and planning assistance to all planners and equipment operators, whether they are experts or newcomers, – however, now it is also available as an up-to-date system on the Internet. The user can therefore make sure that the company reacts quickly to changes and innovations and the KST is accordingly regularly supplemented and updated.

A key feature of the new KST is its extensive collection of example systems, with gas inlet sections, burner systems and process control systems. Each example is explained in detail using a flowchart with descriptions of the applications and functions. Notes on the system and the naming of possible components are rounded off with a link to the respective reference standards. Extracts from standards are presented descriptively and are understandably prepared with interpretations by specialists and with links to practical examples.

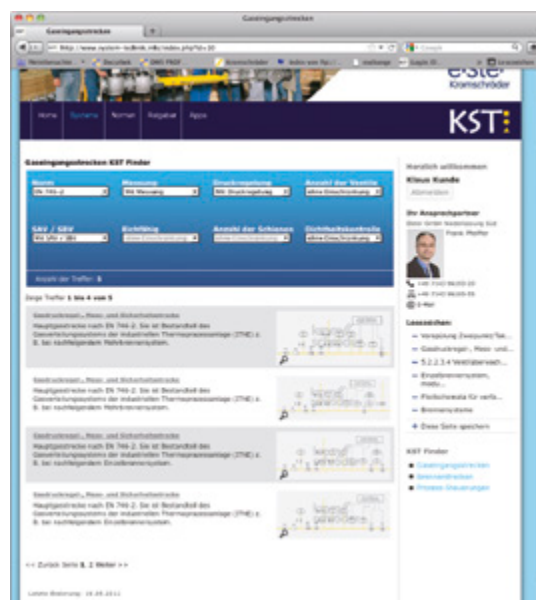

KST

With the modern, future-oriented KST platform, Honeywell Kromschroder is presenting, on the Internet, system knowledge that has been proven over 20 years and which has been available in book form since the start of the 1990s and on CD-ROM since 2003. Further information about KST can be found at www.system-technik.info.

We have what you need!
Since our range of products and services leaves nothing to be desired!



Pot burners BIC+SLG

Honeywell Kromschröder pot burners ensure a homogeneous temperature distribution in reducing and oxidizing kiln atmospheres. Existing gas lances can be exchanged without additional installation effort. It is possible to adapt the burners to any pot cover on the basis of the well-known Honeywell Kromschröder high-speed burners.

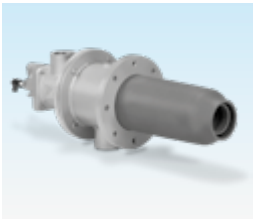

Annular excess air burners BIC+RSG

Regardless of the control method – be it cyclical or modulating control, the Honeywell Kromschröder annular excess air burner is designed for high-speed kilns with closed combustion chambers. The secondary air allows the flame temperature to be matched to the kiln temperature with a high burner pulse magnitude. A large control range for both oxidizing and reducing combustion is then possible. Secondary air in-feed achieves short cooling times.

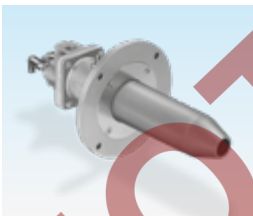

Excess air burners BIC..L

This burner can be ignited at all capacity settings over the entire control range. The extremely high air excess reaching up to approx. 1500% ensures a very high pulse magnitude even at a low burner rating. The BIC..L can thus be used to optimize applications requiring precise temperature control and consistent product quality. The modular design means that it can be easily adapted to any kiln geometry.

Self recuperative burners ECOMAX®

Burners with integrated recuperator ECOMAX® realize energy savings of up to 30% due to air pre-heating up to 700°C. They are used for direct heating or in conjunction with single-ended radiant tubes for indirect heating of kiln systems.

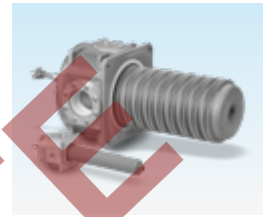

Forced draught burners PBG

Completely pre-assembled and pre-wired burner unit with mounted fan, gas safety and control system and burner control unit for applications in industry. Typical applications include drying systems, hot-air generators, flue air purification or process gas heating.



Burners BICA

This BIC burner version with reduced weight is an ideal complement in the capacity range of tunnel and roller hearth kiln systems.

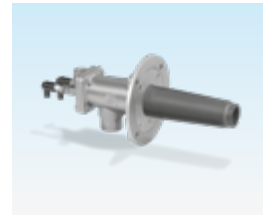

Ceramic tube sets TSC

The TSC ceramic tube set covers the entire range of user-specific requirements thanks to different versions depending on flame shape, capacity, flue gas outlet velocity or application temperature.

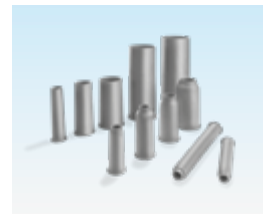

Insulation package

Long-life burner insulation system to protect burners against aggressive kiln atmospheres and thermal stress. This sturdy, patented system – for roof or side-wall mounting as required – is directly mounted on new burners or can be retrofitted to existing installations.

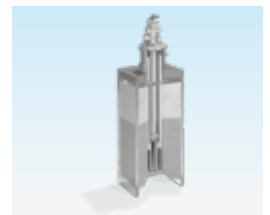

And this can also help you to optimize your processes.



Controls series valVario

The controls series valVario can be used for safety, control and regulation purposes in air and gas supply systems to gas appliances. It can also be used for main gas control and safety. valVario is approved for a maximum inlet pressure of 500 mbar and allows higher flow rates with the same nominal size. Simple installation is just one of many advantages of its compact design. On the standard version, the flow adjustment can be checked using an indicator, while a blue LED is used to check the overall function.



Actuators IC 20, IC 40

High-quality kiln systems make a significant contribution to the production of high-quality products in the fine-ceramics and heavy-clay industries.

Honeywell Kromschroder actuators of the IC 20 and IC 40 Series for direct mounting on butterfly valves BVG (F), BVA (F) and BVH (S) for gas, cold air and hot air up to 450°C have proved their worth throughout the world. Actuator IC 20 is controlled by a three-point step signal. Due to its outstanding flexibility, the IC 40 is suitable for various control types ranging from continuous control to staged control.

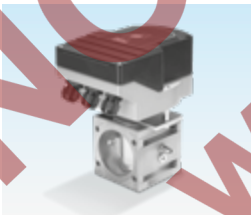

Lambda controls with linear flow control LFC

Constantly growing demands on the control quality of kiln atmospheres require high-quality and nevertheless cost-effective adjustment devices.

Honeywell Kromschroder new generation linear flow controls meet these requirements. They are ideal for use in large lambda and capacity ranges with continuous control for uninterrupted duty.

Protective system control FCU 500

The protective system control FCU 500 is designed to monitor and control central safety functions, e.g. Gasmin, Gasmax, Airmin, pre-purge, tightness test, high temperature operation or start enable for burner control units, in multiple burner systems on industrial kilns. The FCU can be used centrally to control several zones or in the individual zones as protective system and capacity control. If the centrally checked safety requirements, e.g. pre-purge, flow detector and pressure switch scan, have been met, the FCU 500 issues the start enable signal to the burner control units.



Automatic burner control units IFD 2xx and IFD 4xx

The IFD Series are designed for directly ignited burners in intermittent and continuous operation. Flame control is provided by an ionization signal or a UV sensor. The burner status and the level of the flame signal can be read directly from the unit. Specifications: IFD 2xx with one gas valve output; restart can be activated on IFD 258; IFD 2xx-I with integrated electronic ignition. IFD 4xx has 2 valve outputs and is suitable for multi-flame control; restart available as an option.



Burner control unit BCU®

The BCU® Series replaces the local control cabinet. It unites the functionally interrelated components of automatic burner control unit, ignition transformer, operation-control module for Manual/Automatic mode and operating and fault diagnostic system in a compact metal housing. It is suitable for intermittent and continuous operation. Parameterization and extended diagnostics are performed using the PC software BCSOFT. BCU 440 for ionization-controlled, single-stage burners with optimized connection equipment for zonal wiring; BCU 460, BCU 465 and BCU 480 for ionization- or UV-controlled burners with optional Profibus DP bus system.





Extenso-Heat lance burners installed on the rooftop of a ceramics tunnel kiln

Heating Solutions for the Ceramics Industry

For brick, whiteware and ceramics manufacturing, Honeywell Thermal Solutions offers a wide range of burner solutions - ideally suited for specific manufacturing requirements in tunnel kilns, pre-dryers, spray dryers, mineral flash dryers, micronizer jet mills, mineral pulverizing mills, and frit melting kilns.

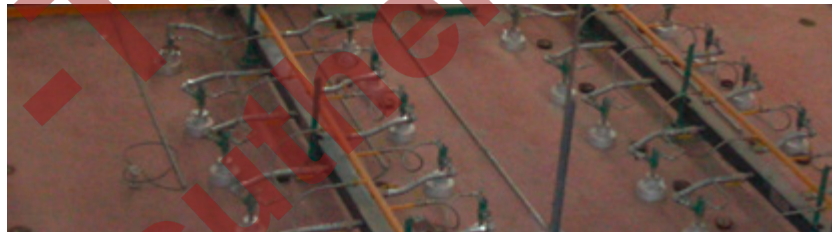

Lance burner ExtensoHeat

The ExtensoHeat lance burner is designed for firing zones of continuous kilns for bricks, roof tiles and rough ceramic products. It is ideal for rooftop installations and furnace zones with operating temperatures above 750 °C (1382 °F). The burner lance extends through thick furnace walls and is capable of up to 60% excess gas operation.

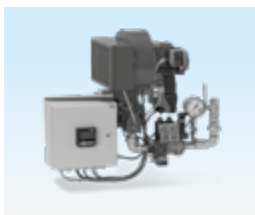

Package burner HeatPak

Completely pre-assembled and pre-wired burner packages based on either RatioMatic, RatioAir or ThermAir with mounted fan, gas safety and control system and automatic burner control unit for applications in industry.

Thanks to their compact design, both conversion of existing systems and initial installation can be implemented within a very short time. Control is carried out using air/gas ratio control (RMHP and RAHP) or gas-only control (TAHP) using linear flow control LFC in the gas circuit with a constant air volume.

ExtensoHeat	
Type	Nozzle-mixing
Number of sizes	1
Capacity range	132 kW (500 kBTU/h)*
Turndown	6:1
Max. process temperature	1500°C (2300°F)
Fuels	Natural gas, butane, propane and other types of fuel gas
Key attributes	
Flame viewing port.	
Simple and reliable.	
Durable construction.	
Adjustable air and gas valves for precise control.	

RatioMatic HeatPak RMHP	
Number of sizes	5 (size 02, 03, 05, 07, 11)
Capacity range	200 – 1100 kW (756 – 4160 kBTU/h)
Fuels	Natural gas, propane, butane

RatioAir HeatPak RAHP	
Number of sizes	5 (size 01, 02, 03, 06, 09)
Capacity range	100 – 900 kW (380 – 3400 kBTU/h)
Fuels	Natural gas, propane, butane

ThermAir HeatPak TAHP	
Number of sizes	6 (size 01, 02, 03, 05, 09, 10)
Capacity range	100 – 1045 kW (380 – 3950 kBTU/h)
Fuels	Natural gas, propane, butane



ThermJet



ThermJet ceramic

High-velocity burner ThermJet

For industrial furnaces and firing systems in the metals industries (ferrous and non-ferrous) as well as the ceramics industry. Other fields of application include thermal oxidizers (incineration) and a variety of drying processes. ThermJet is a direct fired, nozzle-mixing burner that is designed to fire an intense stream of hot gases through a high velocity nozzle. The extremely high velocity of the gases improves temperature uniformity, product quality and system efficiency. ThermJet is available in either high velocity or medium velocity versions in 14 sizes. ThermJet can be adapted to operate with either ambient or preheated combustion air.

ThermJet	
Type	Nozzle-mixing
Number of sizes	14 (size 15 – 2000)
Capacity range	40 – 5280 kW (0.15 – 20 MBTU/h)*
Turndown	10:1 on ratio 50:1 with fixed air
Max. process temperature	1540°C (2800°F)
Max. combustion air temperature	540°C (1000°F)
Fuels	Natural gas, propane, butane, coke oven gas, other gases on request
Key attributes	Versions available for preheated air. Easy set-up with built-in metering. Robust, reliable performance. High turndown plus high excess air capability. Alloy, ceramic and refractory combustor options. Flame speeds up to 207 m/s (680 ft/s). Flexible control: high/low, on-ratio, or fixed-air.

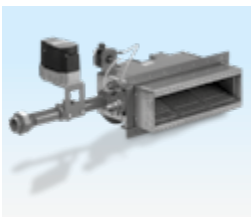

Line burner AirHeat v2

AirHeat v2 is a completely packaged line burner. Applications include ovens, driers, fume incinerators and similar industrial equipment. This burner provides simple, reliable operations, plus lower CO emissions than other competitive air heating burners. All standard models feature an integrated combustion air blower mounted on the burner's steel case. AirHeat v2 provides stable operation over a wide range of duct velocities without the need to install a profile plate. Available with combustion air blowers mounted remotely from the burner (e.g. outside of the duct).

AirHeat v2	
Type	Nozzle-mixing
Number of sizes	Modular
Capacity range	260 kW/300 mm (1 MBTU/h/foot)*
Turndown	40:1
Max. process temperature	815°C (1500°F)
Fuels	Natural gas, propane
Key attributes	Extremely low CO emissions. Compact, modular design. Robust, reliable performance.

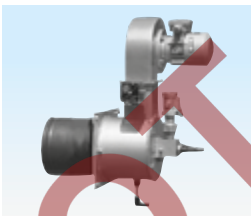

Package burner VALUPAK

The MAXON VALUPAK® gas burner provides a convenient, packaged solution for direct fired heating applications in ovens and dryers. The burner fires cleanly into applications with balanced pressure where high turndown of over 40:1 is required for precise temperature control. Durable steel construction provides years of reliable service. VALUPAK® is available in wide variety of packaged forms to suit your application for a bolt-on solution.

VALUPAK	
Type	Nozzle-mixing
Number of sizes	6
Capacity range	2 to 1125 kW (7 to 3,840 MBTU/h)
Turndown	20:1 to 62:1
Fuels	Natural gas, propane
Key attributes	Ease of installation Operation with low maintenance requirements



Forced draft burner OVENPAK® 400

MAXON's OVENPAK® 400 Series is the world's most flexible and reliable industrial burner. The OVENPAK® burns most any fuel gas and requires only low pressure fuel. This natural gas burner provides clean combustion with low NOx levels while providing unmatched turndown.

OVENPAK® Gas Burners provide outstanding performance in a variety of oven and drying applications including ceramics.

OVENPAK 400	
Type	Nozzle-mixing
Number of sizes	Over 90 different styles and sizes
Capacity range	147 to 4835 kW (500 to 16,500 MBTU/h)
Turndown	40:1 to 65:1
Max. process temperature	816°C (1500°F)
Fuels	Natural gas, propane, butane
Key attributes	Low fuel pressure requirement.

OVENPAK is available in low emissions version: OVENPAK-LE

Contact your local HTS representative for more information.

NOT UP-TO-DATE
www.docuthek.com

Contact

www.kromschroeder.com → Process Heat → Sales
Elster GmbH
Strothweg 1 · 49504 Lotte (Büren)
Germany
Tel. +49 541 1214-0
hts.lotte@honeywell.com
www.ThermalSolutions.honeywell.com

We reserve the right to make
technical modifications in the
interests of progress.
Copyright © 2018 Elster GmbH
All rights reserved.

Honeywell
THE POWER OF **CONNECTED**