

# Elster® GasLab Q2

## Real-time Natural Gas Analyzer

### Brief Information

Growing energy needs, globalization and the liberalization of the natural gas trade are driving demand for efficient and innovative gas measuring equipment, particularly equipment for analysing gas quality. One aspect of this trend is the global distribution of gases from various sources and in various qualities. A large number of processes relating to the use of gas, such as gas turbines, are very sensitive to varying gas parameters and must be adjusted or regulated accordingly. Alternatively the range of gas parameters can be limited by mixing gas in the transport network. Both cases require efficient process measuring equipment for gas quality.

While energy measurement in the distribution network is becoming more and more important, the need for simple and low maintenance analyzers is increasing. The billing to end customers needs to be made easy and more accurate. As opposed to the "classic" gas chromatograph solution, the Honeywell Elster® GasLab Q2 does not use carrier and mixed calibration gases or combustion air supply which means less cost of ownership for the user.

The Honeywell Elster® GasLab Q2 Gas Quality Analyzer determines the calorific value, Wobbe index and other parameters in natural gas. The applications of the device range from fiscal energy metering to measurement, control and regulation. One major application is control of the gas turbine of power plants to optimize efficiency, pollutant emissions and system load with fluctuating gas qualities. Another application is gas blending for managing the gas specifications in transportation.

The GasLab Q2 operates continuously and flameless in contrast to gas chromatographs or Wobbe-index analyzers. Therefore a safe, fast and continuous measurement is ensured. The measuring principle of the GasLab Q2 is based on the determination of the infrared absorption and the thermal conductivity of the measuring gas. This data is used in a correlative model to determine the gas quality.

The GasLab Q2 is designed to operate in many hazardous areas and wide ambient temperature ranges. This simplifies installation and allows the Analyzer to be placed close to the process supporting a short response time.

In measurement mode, the gas quality calculations are updated every second. To minimize gas transport delays between the sample tap and GasLab Q2, a bypass flow meter is integrated into the housing. Routine calibration is performed automatically at a user-programmed time and day, a simple binary mixture.

*(cont. on next page)*



## FEATURES & BENEFITS

### Main Features

- Determination of main gas parameters: calorific value/Wobbe index/density/CO<sub>2</sub> concentration/methane number etc.
- Flameless, no air or carrier gas needed
- Fast, continuous measurement
- Easy operation
- Small footprint:  
Low investment and maintenance costs

### Applications

- Fiscal metering
- Gas turbine control for power plants
- Burner control
- Biogas
- Gas blending

### Benefits

- Installation, cost saving due to easy engineering and commissioning
- Less downtime for gas turbine installations
- More energy efficient turbine control because of quick response
- Less off-spec gas for blending stations
- Cleaner burner regulation
- Optimized emission of processes
- Better end product quality control

(cont. from previous page)

The analyzer has gas connections for sample gas, calibration gas, sensor vent and optional bypass outlet. Electrical connections for power and I/O communications are conveniently accessible in the top housing.

The measured values are communicated via Modbus protocol and analog outputs. Modbus is available through two serial ports and the Ethernet interface. Additionally it is possible to connect external signals to monitor contact closures, e.g. low pressure limit of calibration bottle or sampling system status.

The integrated display shows the measurement values and operating conditions of the analyzer. The analyzer can be operated via a touch panel or by using a web browser connected to the device. Computer software is used for configuration, data display and recording.

The user-friendly Elster GasLab Q2 provides customers with fast, accurate gas quality measurements for a low capital investment and minimal ownership costs."

## Elster GasLab Q2 Technical Specifications

Technical Data				
Measurements and Ranges	Measurement Name	Formula	Range	Output
	Gross Calorific Value*	H <sub>s</sub>	800 - 1300 BTU/scf	Yes
	Standard Density*	ρ (rho)	0.04370 - 0.06867 lb/scf	Yes
	Wobbe Index*	W <sub>I</sub>	7 - 72 psi	Yes
	Carbon Dioxide Concentration	CO <sub>2</sub>	0-20 mol%	Yes
	Dry/Wet/Saturated CV*			Yes
	Inferior CV and Wobbe*	H <sub>i</sub> , W <sub>I</sub>		Yes
	Methane Number	MZ		Yes
	Ethane Plus Higher Alkanes (Sum)	C <sub>2+</sub>		Yes
Calculated Model Gas Composition	CH <sub>4</sub> ...C <sub>8</sub> H <sub>18</sub> , N <sub>2</sub>			
Measurement Uncertainty	H <sub>s</sub> , W <sub>s</sub> , ρ: ≤0.5%, xCO <sub>2</sub> : ≤0.2mol%			
Repeatability	H <sub>s</sub> , W <sub>s</sub> , ρ: ≤0.1%, xCO <sub>2</sub> : ≤0.1mol%			
Range of Appropriate Gases	Generic Natural Gases			
	Component Name	Formula	Range	Available as Output?
	Methane	CH <sub>4</sub>	70-100 mol%	Yes
	Ethane and Higher Alkanes	C <sub>2+</sub>	0-20 mol%	Yes
	Carbon Dioxide	CO <sub>2</sub>	0-20 mol%	Yes
	Nitrogen	N <sub>2</sub>	0-30 mol%	Yes
	Oxygen	O <sub>2</sub>	≤0.1 mol%	No
	Hydrogen	H <sub>2</sub>	≤0.1 mol%	No
	Water (Gaseous)	H <sub>2</sub> O	≤0.1 mol%	No
Hydrogen Sulphide	H <sub>2</sub> S	0.25 grains/100 scf	No	
Dust, Liquids		Technically Free		
Calibration Gas	Binary mixture (CH <sub>4</sub> /CO <sub>2</sub> ) with automatic calibration cycle			
Gas Manifold	Integrated 2-channel double-block and bleed gas manifold for process and calibration gas			
Operational Pressure/Consumption	Inlet pressure 7 - 58 psi gauge (Up to 72 psi possible, refer to manual for further details**) Flow 0.7...11 scft/h (total including adjustable bypass flow)			
Dynamics	Analysis rate f=1 Hz, reaction time t90≤6s (90% step response / Tested @ NMI)			
Power Supply	24VDC±15% (Including mains fluctuations), max. 96W			
Environment	IP64, -13 to +131°F, 0-100%RH (non-condensing)			
Interfaces	1x TCP/IP, 2x RS485 interface, 4 digital outputs, 2 digital inputs, 4 analog outputs Modbus via TCP/IP and serial			
Data Logger	Integrated logging of measurements as mean values (e.g. on hourly basis) or current values. Integrated logging of measurement system status and external events			
Operational Interface	7-channel capacitive touch panel, internal web page accessible through web browser, PC software (enSuite) for configuration, data logging, display and archive retrieval			
Safety Approvals	Zone 1: Ex II 2G Ex d IIC T4 Gb / Class I Div 2 Groups ABCD T4			
Metrological Approvals	NMI: OIML R140 Class A (0-15% C <sub>2</sub> + and 0-25% N <sub>2</sub> )			

\*according to ISO 6976, ASTM 3588, GPA 2172 at all known reference conditions

\*\*Inlet pressure below 7 psi gauge possible with limitations, contact Elster on request

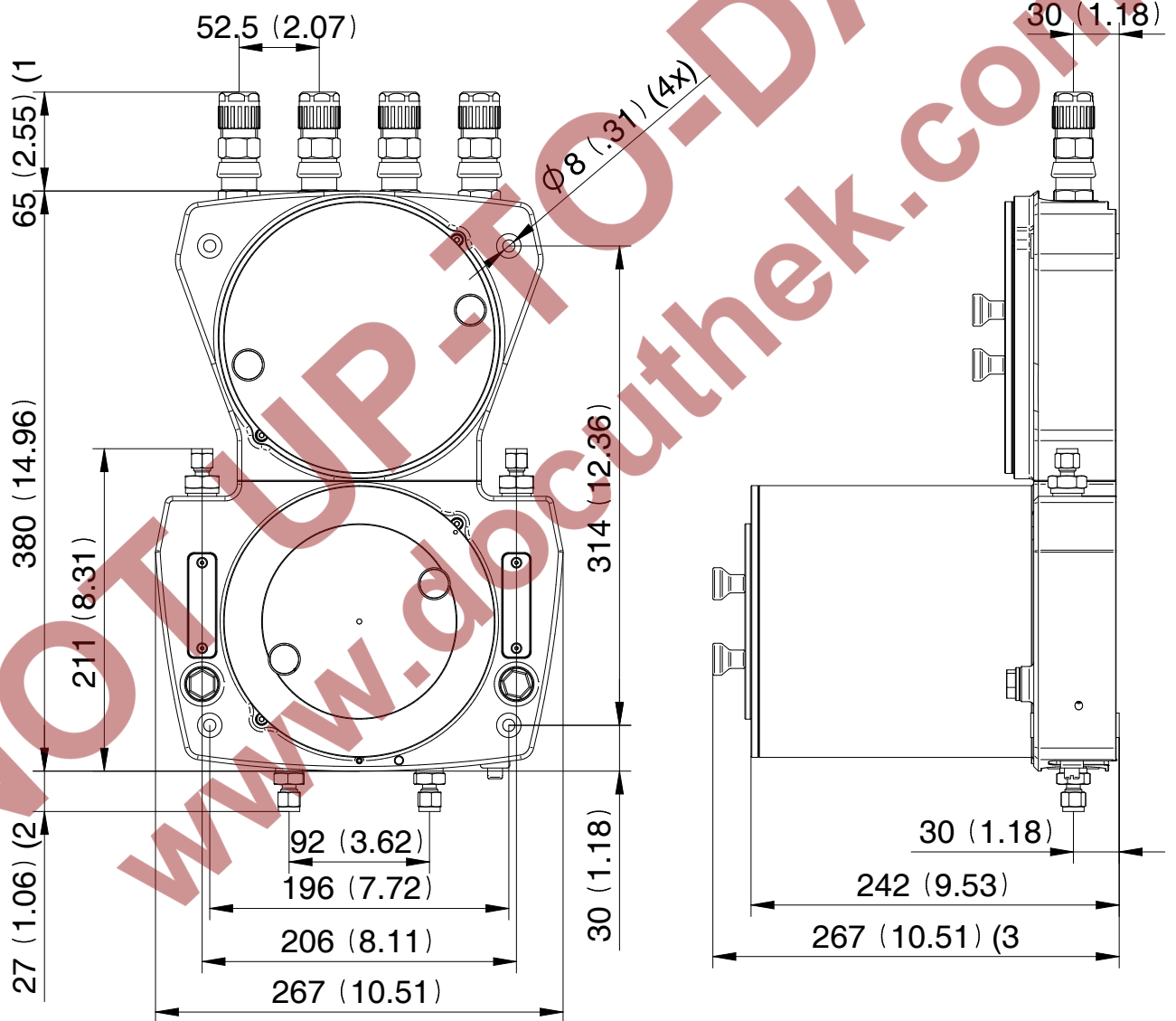
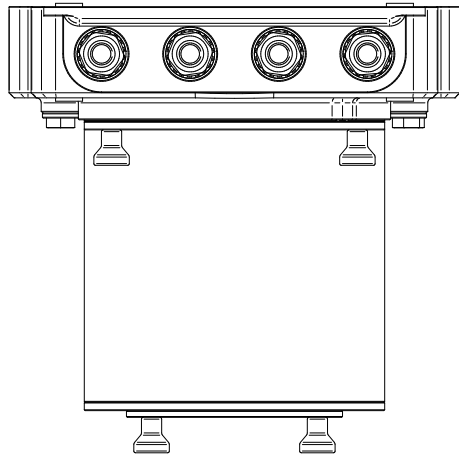

(1 Depending on the type of cable connection and excluding cable clearance

(2 Excluding any clearance for tubing

(3 Including window dust cover

**NOT UP-TO-DATE**  
[www.docuthek.com](http://www.docuthek.com)

**For more information**

To learn more about Honeywell's Integrated Gas Solutions, visit [www.honeywellprocess.com](http://www.honeywellprocess.com) or contact your Honeywell account manager.

**Honeywell Process Solutions**

Germany  
Elster GmbH  
Steinern Str. 19-21  
55252 Mainz-Kastel  
T +49 6134 605 0  
F +49 6134 605 223  
[www.elster-instromet.com](http://www.elster-instromet.com)  
[info@elster-instromet.com](mailto:info@elster-instromet.com)

Houston  
Honeywell 1250 West Sam Houston Parkway  
South Houston, TX 77042  
[www.honeywellprocess.com](http://www.honeywellprocess.com)

SAP no. 73023806 Rev. C

Elster® is a registered trademark of Elster GmbH.

BR-16-08-US-Rev. 1 | 07/17  
©2017 Honeywell International Inc.

**Honeywell**