

Eclipse AirHeat Burners

Model RAH, TAH-R for recirculating air

Operating Instructions Edition 09.12

Version 1

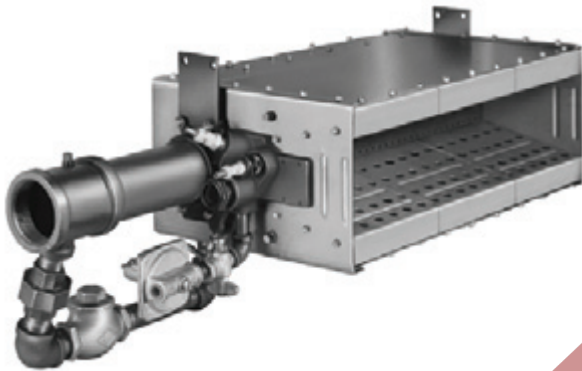

RAH, Front View

Datasheet 142-1

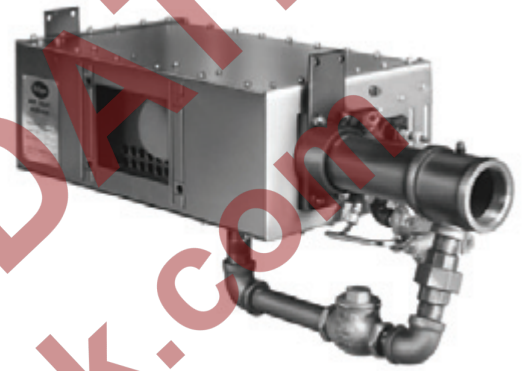

RAH, Back View

Datasheet 142-1

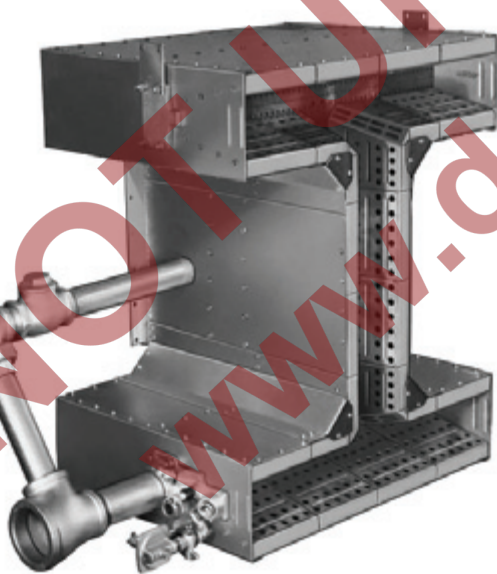

TAH-R, Front View

Datasheet 142-2

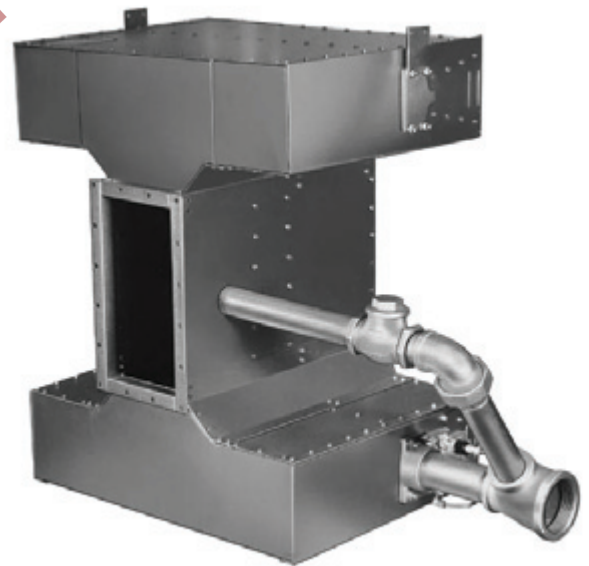

TAH-R, Back View

Datasheet 142-2

Copyright

Copyright 1997 by Eclipse, inc. All rights reserved worldwide. This publication is protected by federal regulation and shall not be copied, distributed, transmitted, transcribed or translated into any human or computer language, in any form or by any means, to any third parties, without the express written consent of Eclipse, inc.

Disclaimer Notice

In accordance with the manufacturer's policy of continual product improvement, the product presented in this brochure is subject to change without notice or obligation.

The material in this manual is believed adequate for the intended use of the product. If the product is used for purposes other than those specified herein, confirmation of validity and suitability must be obtained. Eclipse warrants that the product itself does not infringe upon any United States patents. No further warranty is expressed or implied.

Liability & Warranty

We have made every effort to make this manual as accurate and complete as possible. Should you find errors or omissions, please bring them to our attention so that we may correct them. In this way we hope to improve our product documentation for the benefit of our customers. Please send your corrections and comments to our Technical Documentation Specialist.

It must be understood that Eclipse's liability for its product, whether due to breach of warranty, negligence, strict liability, or otherwise is limited to the furnishing of replacement parts and Eclipse will not be liable for any other injury, loss, damage or expenses, whether direct or consequential, including but not limited to loss of use,

income, or damage to material arising in connection with the sale, installation, use of, inability to use, or the repair or replacement of Eclipse's products.

Any operation expressly prohibited in this manual, any adjustment, or assembly procedures not recommended or authorized in these instructions shall void the warranty.

Document Conventions

There are several special symbols in this document. You must know their meaning and importance.

The explanation of these symbols follows below. Please read it thoroughly.

How To Get Help

If you need help, contact your local Eclipse representative. You can also contact Eclipse at:

1665 Elmwood Rd.
Rockford, Illinois 61103 U.S.A.
Phone: 815-877-3031
Fax: 815-877-3336
<http://www.eclipsenet.com>

Please have the information on the product label available when contacting the factory so we may better serve you.

	www.eclipsenet.com
Product Name	
Item #	
S/N	
DD MMM YYYY	



This is the safety alert symbol. It is used to alert you to potential personal injure hazards. Obey all safety messages that follow this symbol to avoid possible injury or death.



Indicates a hazardous situation which, if not avoided, will result in death or serious injury.



Indicates a hazardous situation which, if not avoided, could result in death or serious injury.



Indicates a hazardous situation which, if not avoided, could result in minor or moderate injury.

NOTICE

Is used to address practices not related to personal injury.

NOTE

Indicates an important part of text. Read thoroughly.



Table of Contents

Safety	4
Safety Warnings	4
Capabilities	4
Operator Training	4
Replacement Parts	4
Storage	4
Information Guide	5
Approval of Components	5
Burner Operating Parameters & Requirements	5
Specifications	6
Control System Requirements	7
Duct Design and Burner Mounting	7
Blower Sizing	9
Burner Firing Arrangements	10
Startup and Adjustment	11
Routine Maintenance	12
Troubleshooting	13
Appendix	i
Notes	ii

Safety

2

Important notices which help provide safe burner operation will be found in this section. To avoid personal injury and damage to the property or facility, the following warnings must be observed. All involved personnel should read this entire manual carefully before attempting to start or operate this system. If any part of the information in this manual is not understood, contact Eclipse before continuing.

Safety Warnings



DANGER

- The burners, described herein, are designed to mix fuel with air and burn the resulting mixture. All fuel burning devices are capable of producing fires and explosions if improperly applied, installed, adjusted, controlled or maintained.
- Do not bypass any safety feature; fire or explosion could result.
- Never try to light a burner if it shows signs of damage or malfunction.



WARNING

- The burner and duct sections are likely to have HOT surfaces. Always wear the appropriate protective equipment when approaching the burner.

NOTICE

- This manual provides information regarding the use of these burners for their specific design purpose. Do not deviate from any instructions or application limits described herein without written approval from Eclipse.

Capabilities

Only qualified personnel, with sufficient mechanical aptitude and experience with combustion equipment, should adjust, maintain or troubleshoot any mechanical or electrical part of this system.

Operator Training

The best safety precaution is an alert and trained operator. Train new operators thoroughly and have them demonstrate an adequate understanding of the equipment and its operation. A regular retraining schedule should be administered to ensure operators maintain a high degree of proficiency.

Replacement Parts

Order replacement parts from Eclipse only. All Eclipse approved valves or switches should carry UL, FM, CSA, CGA and/or CE approval where applicable.

Storage

Store the burner inside. Exposure to the elements can damage the burner.

Information Guide

3

Approval of Components

Limit Controls & Safety Equipment

All limit controls and safety equipment must comply with all applicable local codes and/or standards and must be listed for combustion safety by an independent testing agency. Typical application examples include:

- American: NFPA 86 with listing marks from UL, FM, CSA
- American: NFPA 86C
- European: EN 746-2 with CE mark from TuV, Gastec, Advantica

Electrical Wiring

All the electrical wiring must comply with all applicable local codes and/or standards such as:

- NFPA Standard 70
- IEC60364
- CSA C22
- BS7671

Gas Piping

All the gas piping must comply with all applicable local codes and/or standards such as:

- NFPA Standard 54
- ANSI Z223
- EN 746-2

Where to Get the Standards:

The NFPA Standards are available from:

National Fire Protection Agency
Battery March Park
Quincy, MA 02269
www.nfpa.org

The ANSI Standards are available from:

American National Standard Institute
1430 Broadway
New York, NY 10018
www.ansi.org

Burner Operating Parameters & Requirements

Applications

Eclipse AirHeat Burners are line type burners ideal for generating large volumes of clean, hot air. Applications include ovens, dryers, fume incinerators, and similar industrial equipment.

Combustion air is supplied to "RAH" and "TAH-R" models by a blower located outside the duct. This allows the burners to operate in recirculating airstreams with air temperatures upstream of the burner as high as 750°F (400°C).

Because combustion air is supplied to the burner from outside the duct, RAH and TAH-R burners provide stable operation over a wide range of duct velocities without installing a profile plate around the burner.

Capacities & Supply Pressures

See Datasheet 142-1 and 142-2.

Burner Environment

Weather Protection

Protect burners from the weather.

Combustion Air

Must be free of contaminants. Eclipse strongly recommends use of a combustion air filter to remove airborne particles. If corrosive fumes or materials are present in the air, supply the blower with fresh, clean air from an uncontaminated area of the plant.

Room Openings

If the burner is mounted on the side of the duct, provide at least one square inch of opening to the outdoors for every 4000 Btu/hr (1.2 kW) of burner firing rate. This will admit fresh combustion air.

Access

Provide access to the burner for inspection and maintenance.

**CAUTION**

- It is dangerous to use any fuel burning equipment unless it is equipped with suitable flame sensing devices and automatic fuel shut-off valves. Eclipse can supply such equipment or information on alternate sources.

Specifications

Input	1,000,000 Btu/h per lineal foot (962 kW/m).
Fuels	Natural gas or 100% propane vapor. Call Eclipse for information on using other fuels. See Table 1 below.
Gas Turndown	40:1
Pilot Input	Approximately 25,000 Btu/h (7.3 kW)
Gas Inlet Pressure	<p>800,000 Btu/h/ft (769 kW/m) Natural Gas: 2.2 "w.c. (5.5 mbar) Propane: 0.9 "w.c. (2.2 mbar)</p> <p>1,000,000 Btu/h/ft (962 kW/m) Natural Gas: 3.5 "w.c. (8.7 mbar) Propane: 1.3 "w.c. (3.2 mbar)</p> <p>Gas pressure shown is a differential measured between the gas inlet and a tap on the duct wall, 10" to 20" (254 to 508 mm) downstream of the burner.</p>
Flame Length*	<p>800,000 Btu/h/ft (769 kW/m): 28" (0.71 m) 1,000,000 Btu/h/ft (962 kW/m): 46" (1.17 m)</p>
Piloting	Integral spark-ignited pilot; ignited plug included.
Flame Monitoring	<p>Flame rod supplied. UV scanner adapters are available. For UV scanners, Eclipse recommends a flame monitoring system that terminates the ignition spark and proves the pilot flame without spark prior to opening the main gas valves.</p> <p>CGA requires two flame rods on burners over 3 ft (0.9 m) long. Use a flame monitoring end-plate (Datasheet 140-6) to mount a second flame rod on the end opposite the gas inlet.</p> <p>All burners where the flame must travel over 10' must have flame supervision at both ends. One device must be at the pilot end while the other device must be at the furthest point from the pilot.</p>
Materials	All portions of the burner exposed to the flame are cast iron or #321 stainless steel.
Emissions	Emissions performance depends not only on the burner, but also on other factors such as chamber temperature, chamber design, and heat loading. For estimates of emissions performance in your application, contact Eclipse.
Packaging Options	Available with complete valve trains and control systems. RAH burners and systems can be supplied already mounted on duct sections as specified by the customer. Contact Eclipse for information on custom packaged systems.
Models	<p>RAH Line-shape Datasheet 142-1 TAH-R "I"-shape Datasheet 142-2</p>

*Based on parallel air flow. If mounted in a cross flow, the flame will be shorter

Control System Requirements

Turndown Method

Input is normally controlled by a motorized butterfly valve placed in the gas line leading to the burner.

Regulator Loading Lines

Connect the top diaphragm chambers of the main gas and pilot gas regulators to the duct approximately 10" (250mm) downstream of the burner. This will allow the regulators to maintain a constant supply pressure to the burner regardless of varying pressures in the duct.

Piloting

Pilot gas flow is adjusted shown in Figure 4.

Check Valve

At high fire, the gas pressure at the burner inlet is higher than the air pressure, and the check valve is closed. At low fire, gas pressure falls below the air pressure, and the check valve opens, permitting a small amount of air to mix with the gas. This premix at low fire stabilizes the flame and helps distribute the flame evenly down the length of the burner. See Figure 1.

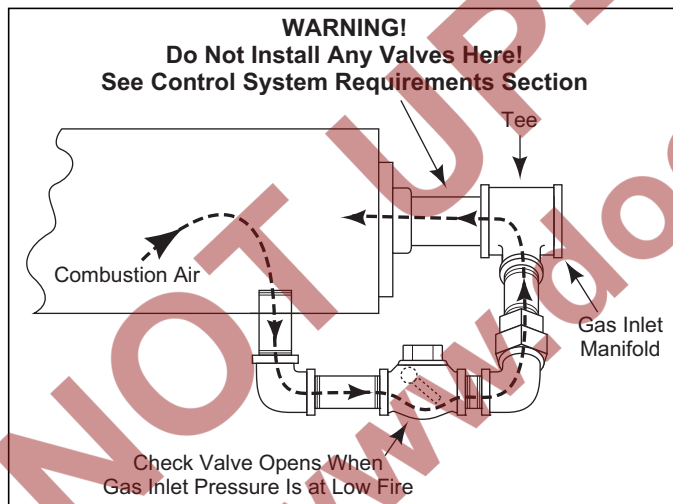

Figure 1. Check Valve Operation



WARNING

- Do not install any valve or controlling device in the gas line between the burner and the check valve tee. Because this section of the gas line carries a partial premix at low fire, it is possible under unusual conditions for the flame to travel back through the pipe to the tee. Devices installed in this section may be damaged and may melt, releasing gas to the atmosphere and causing fires or explosions.

Pressure Switch Connection

See Figure 2 for the typical connection of combustion air and circulating fan limit switches.

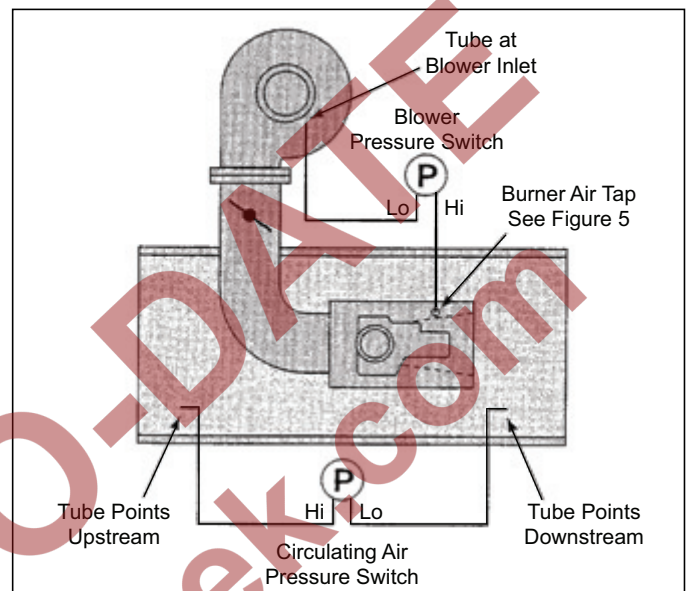

Figure 2. Pressure Switch Location

Ignition

Ignition voltage should be 6000 VAC.

Air Damper

Install an air damper at the combustion air blower inlet, or between the blower and the burner to allow adjustment of combustion air flow.

Duct Design and Burner Mounting

Duct Design

See Figure 3 for typical mounting arrangements and duct designs.

Support

The mounting brackets supplied with the burner are capable of supporting the weight of the burner. Support the blower and air manifold independently of the burner.

Air Manifold

The air manifold must be large enough to supply the required combustion air flow with minimum pressure drop. Do not use more than one 90° bend between the blower and the burner air inlet.

Valve Train Support

Support valve trains independently of the burner.

Gas Piping

Use flexible nipples to allow for thermal expansion of the burner.

Check Valve Piping

Gas flow through the check valve must be horizontal. See Figure 1.

The blower and the adjoining duct (shown in the darker shaded areas) are not part of the burner assembly; they must be purchased and installed separately.

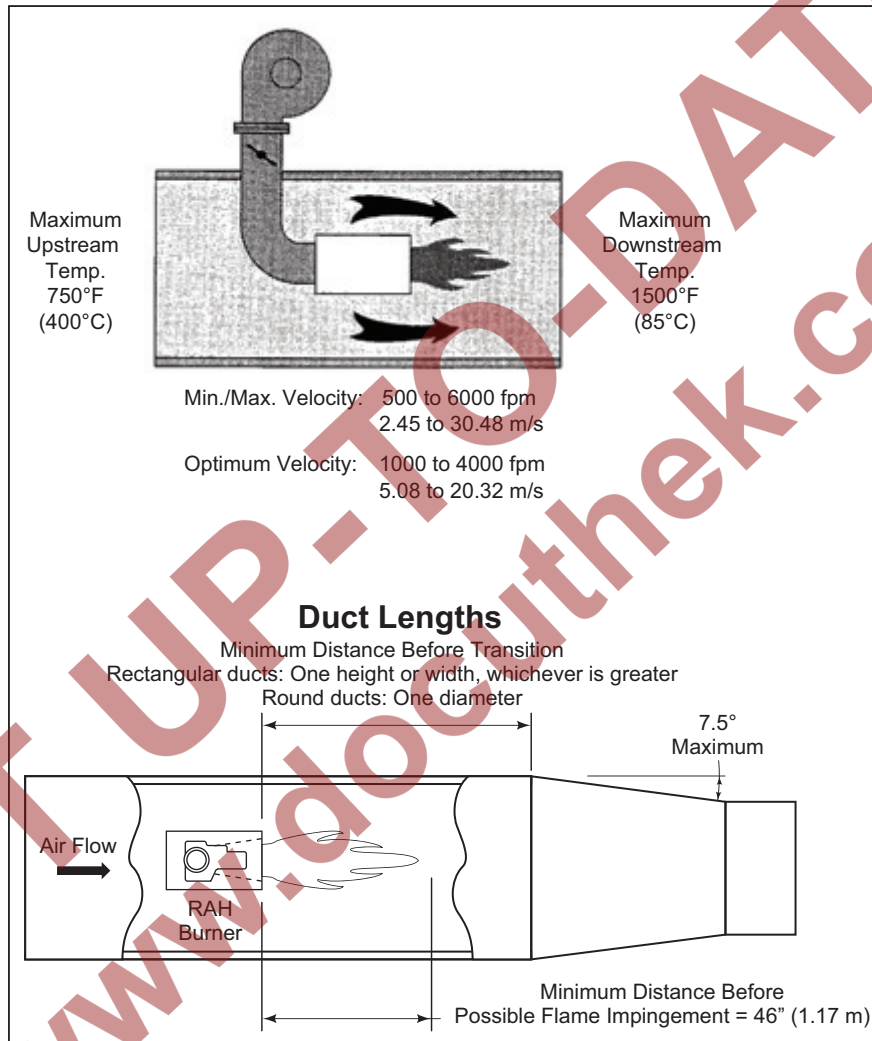

Figure 3. Mounting and Duct Lengths

Notes:

- Provide at least 3" (76 mm) clearance between burner and top, bottom and sides of the duct.
- Profile plates are not required for good burner operation, but uniform velocity must be maintained for full length of burner. If velocity is not uniform, use profile plates to correct it
- Center the burner in the duct.
- Allow a minimum of 46" (1168 mm) from burner to nearest point of possible flame impingement at an input of 1,000,000 Btu/hr. (962 kW/m).
- Support the blower and motor independently of the burner.

Blower Sizing

Blower Volume: Select a burner capable of producing 13,000 cfm per lineal foot of the burner

Blower Pressure: = 2 (maximum duct pressure) - minimum duct pressure

Blower Pressure Calculation: Pressure System	Blower Pressure Calculation: Suction System	Blower Pressure Calculation: Suction-to-Pressure System
<p>Example 1: Maximum Duct Pressure: 30" w.c. Minimum Duct Pressure: 9" w.c. Blower Pressure = $2 (30") - 9" = 51" \text{ w.c.}$</p>	<p>On suction systems, no blower is needed if duct pressure is always - 1.5" w.c. or less, and the ratio of lowest to highest pressure is no greater than 3</p> <p>Example 1: Maximum Duct Pressure: -6" w.c. Minimum Duct Pressure: -20" w.c. Since the ratio of lowest pressure to highest is 3.3, a blower is required: Blower Pressure = $2 (30") - 9" = 51" \text{ w.c.}$</p>	<p>Example 1: Maximum Duct Pressure: 2" w.c. Minimum Duct Pressure: -1.0" w.c. Blower Pressure = $2 (2") - (-1.0") = 5" \text{ w.c.}$</p>
<p>Example 2: Maximum Duct Pressure: 0.5" w.c. Minimum Duct Pressure: 0.2" w.c. Blower Pressure = $2 (0.5") - 0.2" = 0.8" \text{ w.c.}$</p>	<p>Example 2: Maximum Duct Pressure: -0.4" w.c. Minimum Duct Pressure: -0.9" w.c. Blower Pressure = $2 (-0.4") - (-0.9") = 0.1" \text{ w.c.}$</p>	<p>Example 2: Maximum Duct Pressure: 0.5" w.c. Minimum Duct Pressure: -0.2" w.c. Blower Pressure = $2 (0.5") - (-0.2") = 1.2" \text{ w.c.}$</p>
<p>NOTE: On pressure systems, the blower pressure must be at least 1.5" w.c. more than the maximum duct pressure. In Example 2, the blower pressure should be: $0.5" + 1.5" = 2.0" \text{ w.c.}$</p>	<p>NOTE: On suction systems, the blower pressure must be at least 1.5" w.c. more than the maximum duct pressure. In Example 2, the blower pressure should be: $-0.9" + 1.5" = 0.6" \text{ w.c.}$</p>	<p>NOTE: On pressure-to-suction systems, the blower pressure must be at least 1.5" w.c. more than the maximum duct pressure. In Example 2, the blower pressure should be: $0.5" + 1.5" = 2.0" \text{ w.c.}$</p>

Burner Firing Arrangements

The AH burner can fire in any direction. Flow through the burner's check valve, however, must be horizontal. A guide for identifying some standard arrangements is

shown below. Be sure to indicate the appropriate number arrangement when ordering. If no arrangement is indicated, No 1 will be furnished as standard.

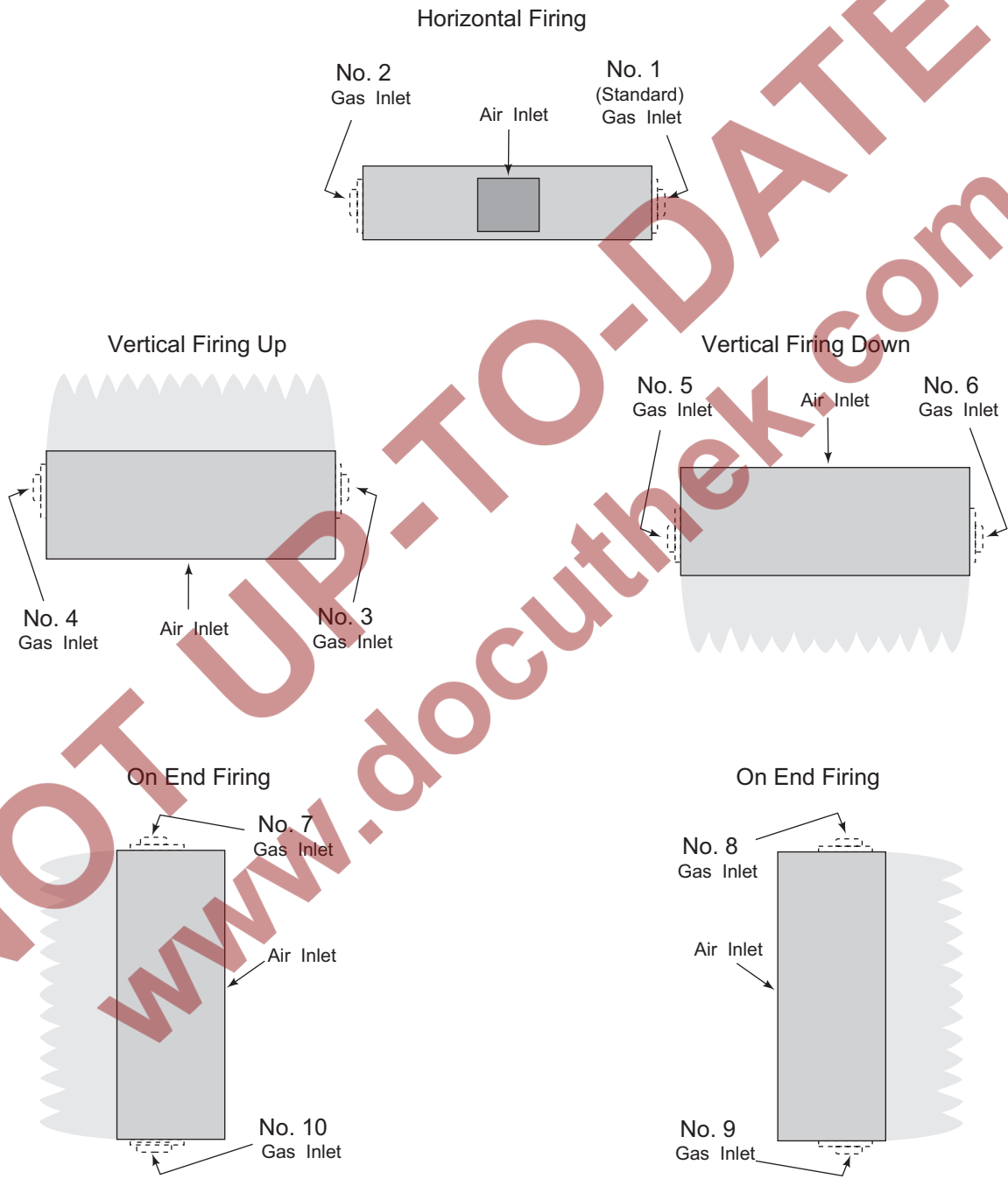

Startup and Adjustment

Initial Settings

Adjust the linkage of the gas control valve so that when heat is called for, the valve is 10° from fully open, and when cooling is required, the valve is approximately 5° from fully closed.

Close all manual gas cocks

With the pilot cock handle in the closed position, remove the top screw and turn the adjusting screw five turns out from fully closed. See Figure 4.

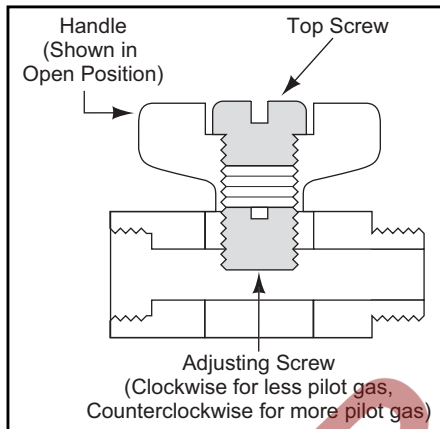

Figure 4. Pilot Cock

Start Blower

Start the combustion air blower on the burner. Check the rotation to make sure it is correct. If not, have a qualified electrician rewire the blower for proper rotation.

Start Circulation Fan

Start the duct circulation fan.

Set Air Pressure Drop

Measure the air pressure drop across the burner as shown in Figure 5.

Adjust the blower damper until the air pressure drop is between 0.4 "w.c. (1 mbar) minimum and 1.0 "w.c. (2.5 mbar) maximum. For a given input, lower air pressure drops will produce a longer flame, and higher drops will produce a shorter flame.

Large Burners Only: Some models, such as the 640, 680, and 720 TAH-R burners, contain a butterfly valve in the check valve line as shown in Figure 6. On these models, after setting the air flow as described in the previous paragraph, measure the air pressure drop between the gas pressure tap and the duct as shown in Figure 5. Gas flow must be off. Adjust the butterfly valve to produce an air pressure drop of 0.2 "w.c. (0.5 mbar).

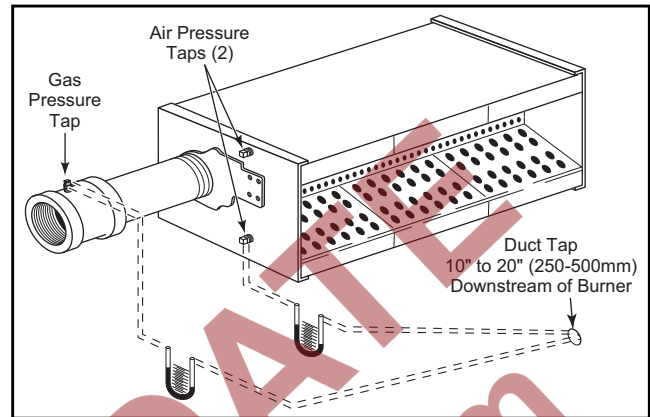

Figure 5. Pressure Measurement

Start Spark

Energize the ignition spark.



WARNING

- Do not touch the ignition rod, ignition wire, or transformer while the spark is energized, or you will get a shock.

Set Pilot Flow

Open all pilot gas valves, including the handle of the pilot cock, see Figure 4. The pilot should light.

Turn the pilot adjusting screw to produce a bushy blue flame that provides a flame monitoring signal strong enough to reliably open the gas shut-off valves.

Set Gas Flow

Measure the gas differential pressure as demonstrated in Figure 5.

With the gas control valve at low fire, open all main gas valves. The burner should light with a stable, blue low fire flame that extends evenly down the burner length.

Drive the control valve to high fire and adjust the gas adjusting valve to produce a pressure drop that corresponds to the desired high fire rate, as shown in Figure 7.

When setting high fire, ensure the flame does not impinge on anything downstream of the burner. To shorten the flame length for a given gas input, increase the air pressure drop as described in "Set Air Pressure Drop" paragraph above.

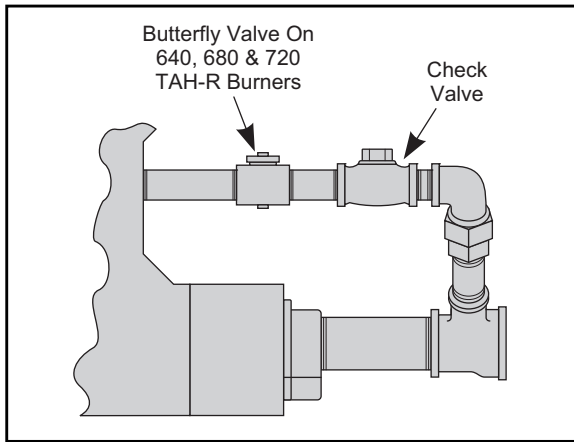

Figure 6. Butterfly in Check Valve Line

Check All Settings

Return the burner to low fire and check to ensure the burner remains lit with a stable flame that extends down the burner length. Cycle the burner between low and high fire several times, checking pressure drops and flame lengths.

Routine Maintenance

Motor Lubrication

Oil the blower motor according to the manufacturer's instructions as printed on the motor label.

Ignition Plug/Flame Rod

Ignition plugs and flame rods wear out over long periods of normal burner operation. Eclipse recommends that the user keep at least one of each in stock at all times to prevent nuisance shutdowns. See Figure 7 for recommended spares.

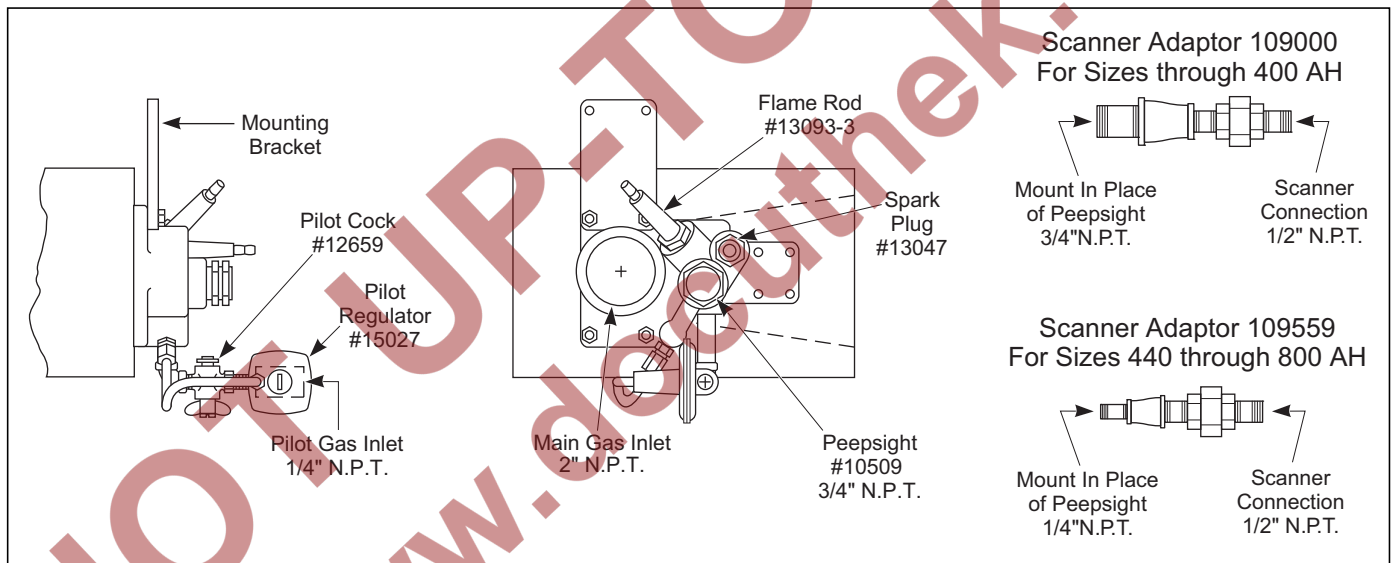

Figure 7. Ignition, Flame Monitoring, and Pilot Component

Troubleshooting

Symptom	Cause	Check	Remedy
Burner does not start initially.	<ul style="list-style-type: none"> Air pressure switches not making. Faulty pressure switches. 	<ul style="list-style-type: none"> Check pressures in duct at location of switch connections. Check electrical portion of switch. 	<ul style="list-style-type: none"> Change pressure connections where a more positive pressure is present.
Burner kicks out shortly after start-up.	<ul style="list-style-type: none"> Low gas pressure switch set too high. 	<ul style="list-style-type: none"> Check low pressure switch setting. 	<ul style="list-style-type: none"> Reset
Pilot will not ignite on initial light-off.	<ul style="list-style-type: none"> Raw gas fed into pilot causing carbon hair on spark plug. 	<ul style="list-style-type: none"> Check spark plug for carbon hair; also check gap on plug. This gap should be 3/64" (1.3 mm) - 3/32" (2.3 mm). 	<ul style="list-style-type: none"> Adjust pilot gas cock. Screw needle closed. With transformer powered open needle slowly, 1/4 turn at a time.
Flame failure when burner goes too high fire.	<ul style="list-style-type: none"> Gas pressure to pilot regulator too high. Pilot casting bolts are not tight enough. Pilot regulator not reacting fast enough to duct pressure changes. Check valve stuck open Too much pilot gas. 	<ul style="list-style-type: none"> Check pilot gas pressure to regulator (should be 1 PSIG, 70 mbar, maximum). Check tightness of bolts. Check impulse line for possible dirt clogging. Check impulse line duct connection for effective pressure being transmitted to regulator. 	<ul style="list-style-type: none"> Relocate pilot gas line or use second pilot regulator. Tighten bolts. Clean impulse line of any dirt particles and relocate duct connection to transmit maximum duct pressure. Clean check valve. Reduce pilot gas flow.
Flame failure when main burner returns from high to low fire.	<ul style="list-style-type: none"> Gas pressure to pilot regulator. Under-gassing pilot 	<ul style="list-style-type: none"> Check pilot gas pressure to regulator (should be 1 PSIG, 70 mbar, maximum). Check pilot regulator inlet and outlet gas pressures. Check pilot flame. Check impulse line for possible dirt clogging. Check impulse line duct connection for effective pressure being transmitted to regulator. 	<ul style="list-style-type: none"> Relocate pilot gas line or use second pilot regulator. Open needle on pilot adjusting cock slowly 1/4 turn at a time. Clean impulse line of any dirt particles and relocate duct connection to transmit maximum duct pressure.
Main flame too large at high fire	<ul style="list-style-type: none"> Gas pressure too high at burner inlet. Combustion air pressure too low. Check valve stuck open 	<ul style="list-style-type: none"> Check gas pressures. Check air pressure differential. 	<ul style="list-style-type: none"> Screw out on main gas pressure regulator. Adjust linkage on gas control valve to hold valve less than fully open when at high fire. Open air shutter on makeup air blower. Clean check valve
Main flame not extending beyond face of burner at high fire.	<ul style="list-style-type: none"> Air pressure differential too high. Burner not firing rated input. Burner gas holes plugged. 	<ul style="list-style-type: none"> Check air pressure differential between combustion air manifold and main duct. Check gas pressure differential. Check gas holes for dirt or lint. 	<ul style="list-style-type: none"> Close air shutter on makeup air blower. Screw in on main gas pressure regulator to provide more gas. Clean gas holes with #42 MTD (2.3 mm) drill. Clean air holes with #27 MTD (3.6 mm) drill.
Main flame long and yellow	<ul style="list-style-type: none"> Velocity past burner lower than 500 FPM (2.5m/s). Check valve stuck open. 	<ul style="list-style-type: none"> Check velocities and rotation of main circulating fan. 	<ul style="list-style-type: none"> Open shutter on makeup air blower. Clean check valve.

Appendix

Conversion Factors

Metric to English

From	To	Multiply By
actual cubic meter/h (am ³ /h)	actual cubic foot/h (acfh)	35.31
normal cubic meter/h (Nm ³ /h)	standard cubic foot /h (scfh)	38.04
degrees Celsius (°C)	degrees Fahrenheit (°F)	(°C x 9/5) + 32
kilogram (kg)	pound (lb)	2.205
kilowatt (kW)	Btu/h	3415
meter (m)	foot (ft)	3.281
millibar (mbar)	inches water column ("w.c.)	0.402
millibar (mbar)	pounds/sq in (psi)	14.5 x 10 ⁻³
millimeter (mm)	inch (in)	3.94 x 10 ⁻²
MJ/Nm ³	Btu/ft ³ (standard)	26.86

Metric to Metric

From	To	Multiply By
kiloPascals (kPa)	millibar (mbar)	10
meter (m)	millimeter (mm)	1000
millibar (mbar)	kiloPascals (kPa)	0.1
millimeter (mm)	meter (m)	0.001

English to Metric

From	To	Multiply By
actual cubic foot/h (acfh)	actual cubic meter/h (am ³ /h)	2.832 x 10 ⁻²
standard cubic foot /h (scfh)	normal cubic meter/h (Nm ³ /h)	2.629 x 10 ⁻²
degrees Fahrenheit (°F)	degrees Celsius (°C)	(°F - 32) x 5/9
pound (lb)	kilogram (kg)	0.454
Btu/h	kilowatt (kW)	0.293 x 10 ⁻³
foot (ft)	meter (m)	0.3048
inches water column ("w.c.)	millibar (mbar)	2.489
pounds/sq in (psi)	millibar (mbar)	68.95
inch (in)	millimeter (mm)	25.4
Btu/ft ³ (standard)	MJ/Nm ³	37.2 x 10 ⁻³



Notes

NOT UP-TO-DATE
www.docuthek.com

NOT UP-TO-DATE
www.docuthek.com